

PW REVIZER



QUANTITATIVE APTITUDE

- ▶▶ Topic-wise MCQs from Past papers, RTPs & MTPs
- ▶▶ Chapter-wise Cheat Sheet- Short Notes and Formulas
- ▶▶ Chapter-wise Answer Key + Smart Hints
- ▶▶ Quick Test after Every Chapter

Anurag Chauhan

EDITION: Second

Published By: Physicswallah Limited



Physics Wallah Publication

ISBN: 978-93-7467-085-9
MRP: 479/-
Mobile App: Physics Wallah (Available on Play Store)



Website: www.pw.live
Youtube Channels: CA Intermediate by PW (@CAintermediatebyPW)
CA Wallah by PW (@CAWallahbyPW)
CA Final by PW (@CAFinalbyPW)
Email: publication@pw.live
SKU Code: BKP2511623416

Rights

All rights are reserved with the Publisher. No part of this book may be used or reproduced in any manner whatsoever without written permission from the author or publisher.

In the interest of the student community:

Circulation of soft copy of Book(s) in PDF or other equivalent format(s) through any social media channels, emails, etc. or any other channels through mobiles, laptops or desktop is a criminal offense. Anybody circulating, downloading, or storing, a soft copy of the book on his device(s) is in breach of the Copyright Act. Further photocopying of this book or any of its material is also illegal. Do not download or forward in case you come across any such soft copy material.

Disclaimer

A team of PW CA Wallah faculties and experts with a deep understanding of the subject has worked hard for the creation and curation of this book.

While the content creators, editors and publisher have used their best efforts in preparing these books. The content has been checked for accuracy. As the book is intended for educational purposes, the author shall not be responsible for any errors contained in the book.

The publication has designed the content to provide accurate and authoritative information with regard to the subject matter covered.

This book and the individual contribution contained in it are protected under Copyright Act by the publisher.

(This book shall only be used for educational purposes.)

Preface

At **CA Wallah by PW**, our mission is simple—help CA Foundation aspirants prepare smarter with content that is accurate, exam-focused, and easy to revise.

In a market filled with study materials, we are delighted to introduce the **first edition of the CA Foundation PW Revizer**, a book designed to prioritize clarity, relevance, and practical utility—saving you time while strengthening your exam performance.

This Revizer is the result of close collaboration between experienced subject experts, content developers, reviewers, and faculty mentors. We also gratefully acknowledge the contribution of **Mrs. Rishma W. Grover (Content Professor)**, whose subject expertise and dedication have been invaluable in enhancing the quality and depth of this book. Together, they have distilled concepts into concise explanations, selected high-yield problems, and curated exam-oriented practice that closely reflects real question patterns.

We believe in **clear concepts + smart practice**. The core objective of this Revizer is to give you an edge by offering short, crisp, and high-quality content that's easy to revise and practice. With a multi-pronged approach—conceptual highlights, formula summaries, topic-wise MCQs from past papers, and quick chapter-wise tests—you'll be able to revise rapidly while strengthening accuracy, speed, and recall under exam conditions.

Designed as a **compact revision and practice companion**, this book works best when paired with your regular study plan, especially for targeted last-stage preparation. Use the quick tests to check your readiness and the smart hints to sharpen your problem-solving strategy.

Key Features

- Topic-wise MCQs from Past Papers, RTPs & MTPs
- Chapter-wise Cheat Sheet (short notes & formulas)
- Answer keys with smart hints for better recall
- Quick tests after every chapter for self-assessment

We hope this Revizer becomes a reliable, time-saving partner in your CA Foundation journey. Wishing you focused preparation and great success!

About the Author

Anurag Chauhan Sir, a distinguished Educator and Mathematician, is renowned for his innovative approach to teaching Mathematics and Statistics. He holds a B.Com (Hons.), M.Com, and B.Ed.

With over 14 years of rich teaching experience, he has transitioned from offline classrooms to becoming a trusted mentor to more than 10 lakh students globally.

He is highly experienced in teaching Class 11th, 12th CUET, NDA and CA Foundation, where he simplifies complex concepts and makes them engaging through real-life application.

Known for his unique style of integrating real-life problems into lessons, he inspires students to build strong concepts in Mathematics and Statistics, empowering them to excel in both academics and competitive exams.

Content

1. Ratio and Proportion, Indices, Logarithms	1
2. Equations	16
3. Linear Inequalities	29
4. Mathematics of Finance	38
5. Basic Concepts of Permutations and Combinations	54
6. Sequence and Series-Arithmetic and Geometric Progressions	64
7. Sets, Relations and Functions, Limits and Continuity	76
8. Basic Concepts of Differential and Integral Calculus	91
9. Number Series, Coding & Decoding & Odd Man Out	103
10. Direction Test	112
11. Seating Arrangements	122
12. Blood Relation	131
13. Statistical Description of Data and Sampling	142
14. Measures of Central Tendency and Dispersion	162
15. Probability	178
16. Theoretical Distributions	194
17. Correlation and Regression	206
18. Index Number	219
Mock Test Paper Series-I	231
Mock Test Paper Series-II	254



Ratio and Proportion, Indices, Logarithms

Cheat Sheet by Anurag Sir

RATIO

Comparison of 2 or more

Quantities

Same Kind Same Units

$\frac{a}{b}$ is written as $a : b$

a = numerator (First term)
(Antecedent)

b = Denominator (Second term)
(Consequent)

If more than two quantities of same kind are given in ratio then this is called continued Ratio.

Continued Ratio of a , b and c is denoted by $a : b : c$

If two quantities are in $a : b$
then first quantity = ak
and second quantity = bk

- Inverse of $a : b = b : a$
- Ratio compounded of $a : b$ and $c : d$

$$= ac : bd \text{ i.e. } \frac{a}{b} \times \frac{c}{d} = \frac{ac}{bd}$$

- Duplicate ratio of $a : b = a^2 : b^2$
- Triplicate ratio of $a : b = a^3 : b^3$
- Sub duplicate ratio of $a : b = (a)^{1/2} : (b)^{1/2}$
- Sub Triplicate Ratio of $a : b = (a)^{1/3} : (b)^{1/3}$

Commensurable Quantities

If ratio of two quantities is a rational number

E.g., 5 and 2 are commensurable as $\frac{5}{2}$ is a Rational no.

E.g., $\sqrt{5}$ and 2 are incommensurable as $\frac{\sqrt{5}}{2}$ is not a Rational Number.

PROPORTION

Equality of two Ratios make a proportion denoted by $a : b :: c : d$

or $a : b = c : d$

$$\text{or } \frac{a}{b} = \frac{c}{d}$$

$$\text{Ex; } \frac{3}{6} = \frac{8}{16}$$

So, $3 : 6 :: 8 : 16$

- If a , b , c and d are in proportion
So, $a : b :: c : d$
 a , b , c and d are called terms
 a and $d \rightarrow$ Extremes
 b and $c \rightarrow$ Means

Continuous Proportion

For 3 terms a , b and c if $\frac{a}{b} = \frac{b}{c} \Rightarrow b^2 = ac$

then a , b and c are called in continuous proportion where,

a = First Proportional
 c = Third Proportional
 b = Mean Proportional

Continued Proportion

For more than 3 terms a, b, c, d, e, f, \dots

$$\frac{a}{b} = \frac{b}{c} = \frac{c}{d} = \frac{d}{e} = \dots$$

Properties of Proportion

1. Cross Multiplication Rule:

$$\text{If } \frac{a}{b} = \frac{c}{d}$$

$$\text{Then, } ad = bc$$

2. Invertendo Rule:

$$\text{If } \frac{a}{b} = \frac{c}{d}$$

$$\text{Then, } \frac{b}{a} = \frac{d}{c}$$

3. Alternendo Rule:

$$\text{If } a : b = c : d$$

$$\text{then } a : c = b : d$$

4. Componendo Rule:

$$\text{If } a : b = c : d$$

$$\text{i.e., } \frac{a}{b} = \frac{c}{d}$$

$$\text{then, } \frac{a+b}{b} = \frac{c+d}{d}$$

5. Dividendo Rule:

$$\text{If } \frac{a}{b} = \frac{c}{d}$$

$$\text{then, } \frac{a-b}{b} = \frac{c-d}{d}$$

6. Componendo & Dividendo Rule:

$$\text{If } \frac{a}{b} = \frac{c}{d}$$

$$\text{then, } \frac{a+b}{a-b} = \frac{c+d}{c-d}$$

7. Addendo Rule:

$$\text{If } \frac{a}{b} = \frac{c}{d} = \frac{e}{f} = k$$

$$\text{then } \frac{a+c+e}{b+d+f} = k$$

8. Subtrahendo Rule:

$$\text{If } \frac{a}{b} = \frac{c}{d} = \frac{e}{f} = k$$

$$\text{then, } \frac{a-c-e}{b-d-f} = k$$

Allegation Rule

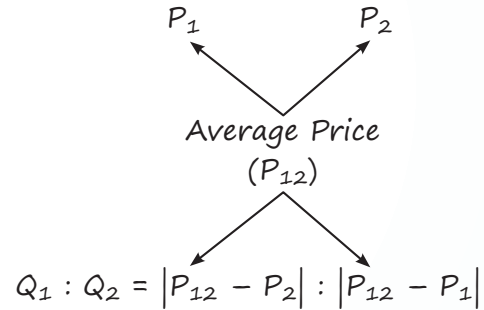

INDICES

If a number 'x' is multiplied 'n' times $x \cdot x \cdot x \dots n$ times = x^n then $x \Rightarrow$ (Base) & $n \Rightarrow$ Power (Index or Exponent).

Properties

1. $a^0 = 1$ where $a \neq 0$

2. $a^{-1} = \frac{1}{a}$ **Calculator $\div =$**

3. $a^{-n} = \frac{1}{a^n}$

Calculator Trick

$a^n = ?$	2^{10}
\Rightarrow 'a' on the screen	\rightarrow '2' on screen
\Rightarrow Press \times	\rightarrow \times
\Rightarrow Press $=$ (n-1) times	\rightarrow $=$ 9 times

Calculator Trick

$a^{-n} = ?$	2^{-10}
\Rightarrow 'a' on the screen	\rightarrow '2' on screen
\Rightarrow Press \div	\rightarrow \div
\Rightarrow Press $=$ n times	\rightarrow $=$ 10 times

4. $a^m \cdot a^n = a^{m+n}$
(Same Base & Multiplication then Power add)

Eg.: $x^2 x^{\frac{1}{3}} = (x)^{2+\frac{1}{3}} = (x)^{\frac{7}{3}}$

5. $\frac{a^m}{a^n} = a^{m-n}$

(Same Base & Division then power Subtract)

Eg.: $\frac{x^{10}}{x^3} = x^7$

6. $(a^m)^n = a^{mn}$

Eg.: $(x^2)^5 = x^{10}$

Note: $a^{m^n} \neq (a^m)^n$ ये गलती मत करना

7. $\sqrt[n]{x} = (x)^{\frac{1}{n}}$

(n^{th} Root of a number)

Eg.: $\sqrt{x} = (x)^{\frac{1}{2}}$

Eg.: $\sqrt[3]{x} = (x)^{\frac{1}{3}}$

Eg.: $\sqrt[4]{x} = (x)^{\frac{1}{4}}$

8. If $a^m = a^n$; then $m = n$

9. If $a^m = k$; then $a = (k)^{\frac{1}{m}}$

10. $(abcd)^m = a^m b^m c^m d^m$

CLASS 10TH IDENTITIES

- $\Rightarrow (a + b)^2 = a^2 + b^2 + 2ab$
- $a^2 + b^2 = (a + b)^2 - 2ab$
- $\Rightarrow (a - b)^2 = a^2 + b^2 - 2ab$
- $a^2 + b^2 = (a - b)^2 + 2ab$
- $\Rightarrow (a + b)^3 = a^3 + b^3 + 3ab(a + b)$
- $\Rightarrow (a - b)^3 = a^3 - b^3 - 3ab(a - b)$
- $\Rightarrow a^3 + b^3 = (a + b)(a^2 + b^2 - ab)$
- $\Rightarrow a^3 - b^3 = (a - b)(a^2 + b^2 + ab)$

□ If $x = a^{\frac{1}{3}} + a^{-\frac{1}{3}}$ then $x^3 - 3x = a + \frac{1}{a}$

& If $x = a^{\frac{1}{3}} - a^{-\frac{1}{3}}$ then $x^3 + 3x = a - \frac{1}{a}$

Cyclic Order Tricks

$\rightarrow (a - b) + (b - c) + (c - a) = 0$

$\rightarrow a(b - c) + b(c - a) + c(a - b) = 0$

$\rightarrow (a^2 - b^2) + (b^2 - c^2) + (c^2 - a^2) = 0$

$\rightarrow (a^3 - b^3) + (b^3 - c^3) + (c^3 - a^3) = 0$

$\rightarrow (b - c)(b + c - a) + (c - a)(c + a - b) + (a - b)(a + b - c) = 0$

$\rightarrow \frac{1}{(a-b)(b-c)} + \frac{1}{(b-c)(c-a)} + \frac{1}{(c-a)(a-b)} = 0$

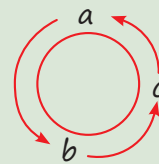

LOGARITHM

If $\log_a(x) = y$ then $x = (a)^y$

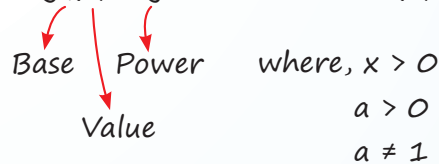

a की power क्या रहे जिससे value x मिले

Common log

$y = \log_{10}(x)$

Natural log

$y = \log_e(x)$

Calculator Trick

(Accurate Answer Trick)

$\rightarrow \sqrt{19}$ times

$\rightarrow -1$

$\rightarrow \times 227695$

$\rightarrow \sqrt{13}$ times

$\rightarrow -1$

$\rightarrow \times 3558$

Used in Calculus

There are many other tricks to find log.

Properties of log

1. $\log_a(1) = 0$
2. $\log_a(a) = 1$
3. $\log(xy) = \log(x) + \log(y)$
4. $\log\left(\frac{x}{y}\right) = \log x - \log y$
5. $\log(x)^n = n \log x$

Note: $[\log(x)]^n \neq n \log x$

ये गलती मत करना

6. $\log_a(x) = \frac{\log_b(x)}{\log_b a}$

7. $\log_x(y) \times \log_y(x) = 1$

8. $\log_{ab}(x) = \frac{1}{b} \log_a(x) = \log_a(x)^{\frac{1}{b}}$

9. $\log_{a^b}(x)^y = \frac{y}{b} \log_a(x)$

10. $a^{\log_a(x)} = x$

QUESTIONS

Ratio

1. If $p : q = r : s$, implies $q : p = s : r$, then the process is called **[MTP-May 2025]**

- (a) Componendo (b) Invertendo
(c) Alternendo (d) dividendo

2. $\frac{3x-2}{5x+6}$ is the duplicate ratio of $\frac{2}{3}$, then find the value of x . **[PYQ-Nov. 2018]**

- (a) 6 (b) 2
(c) 5 (d) 9

3. What is the value of $\frac{p+q}{p-q}$ if $\frac{p}{q} = 7$?

[PYQ-Sept. 2024]

- (a) $\frac{2}{3}$ (b) $\frac{4}{3}$
(c) $\frac{2}{6}$ (d) $\frac{7}{8}$

4. If $x : y = 7 : 8$, then for $6x + 5y : 4x + 3y = ?$

[MTP-May, 2025]

- (a) 11 : 7 (b) 30 : 12
(c) 35 : 24 (d) 41 : 26

5. If $x : y = 4 : 6$ and $2 : x = 1 : 2$, then $y = ?$

- (a) 4 (b) 6
(c) $\frac{1}{2}$ (d) $\frac{3}{2}$

6. If $x : y = 2 : 3$, then $(5x + 2y) : (3x - y)$

[MTP-June 2022]

- (a) 19 : 3 (b) 16 : 3
(c) 7 : 2 (d) 7 : 3

7. If $A : B = 2 : 5$, then $(10A + 3B) : (5A + 2B)$ is equal to

(a) 7 : 4 (b) 7 : 3

(c) 6 : 5 (d) 7 : 9

8. The salaries of A, B and C are in the ratio 2 : 3 : 5. If the increments of 15%, 10% and 20% are allowed respectively in their salaries, then what will be the new ratio of their salaries?

[PYQ-Jan. 2021, July 2021]

- (a) 3 : 3 : 10
(b) 10 : 11 : 20
(c) 23 : 33 : 60
(d) cannot be determined

9. A bag contains 25 paise, 10 paise and 5 paise in the ratio 3 : 2 : 1. The total value is ₹40, then the number of 5 paise coins in the bag is

[PYQ-June 2022, Dec. 2017, Dec. 2016]

- (a) 40 (b) 45
(c) 48 (d) 50

10. A box contains ₹56 in the form of coins of one rupee, 50 paise and 25 paise. The number of 50 paise coins is double the number of 25 paise coins and four times the numbers of one rupee coins. The numbers of 50 paise coins in the box is **[MTP-June, 2024]**

- (a) 64 (b) 32
(c) 16 (d) 4

11. The ratio compounded of 4 : 5 and sub-duplicate of 4 : a is 8 : 15. Then value of " a " is

- (a) 9 (b) 6
(c) 4 (d) None of these

12. The ratio of income of A and B is 5 : 4 and their expenditure is 3 : 2. If at the end of year, each saves ₹1600, then the income of A is

[PYQ-Sept., 2024]

- (a) ₹3,400 (b) ₹3,600
(c) ₹4,000 (d) ₹4,400

Proportion

13. The mean proportional between 8 and 32 is
[MTP-May, 2025]
(a) 4 (b) 16
(c) 24 (d) 40
14. The third proportional to 49 and 21 is
[MTP-Jan., 2025]
(a) 6 (b) 9
(c) 12 (d) 28
15. Fourth proportional to x , $2x$, $(x + 1)$ is:
(a) $(x + 2)$ (b) $(x - 2)$
(c) $(2x + 2)$ (d) $(2x - 2)$
16. The mean proportional between $12x^2$ and $27y^2$ is;
[PYQ-Sept., 2024]
(a) $18xy$ (b) $81xy$
(c) $8xy$ (d) $19.5xy$
17. If $A : B = 3 : 4$, $B : C = 7 : 9$, $C : D = 2 : 3$ and D is 50% more than E , find the ratio between A and E .
[MTP-Dec., 2021]
(a) 2 : 3 (b) 3 : 4
(c) 3 : 5 (d) 7 : 12
18. If $\frac{1}{2}, \frac{1}{3}, \frac{1}{5}$ and $\frac{1}{x}$ are in proportion, then the value of x will be
(a) $\frac{15}{2}$ (b) $\frac{6}{5}$
(c) $\frac{10}{3}$ (d) $\frac{5}{6}$
19. A person has asset worth of ₹1,48,200. He wish to divide it amongst his wife, son and daughter in the ratio 3 : 2 : 1 respectively. From this assets, share of his son will be: [MTP-June, 2022]
(a) ₹24,700 (b) ₹49,400
(c) ₹74,100 (d) ₹37,050
20. X , Y , Z together starts a business, if X invests 3 times as much as Y invests and Y invests two third of what Z invests, then the ratio of capitals of X , Y , Z is
[MTP-June, 2022]
(a) 3 : 9 : 2 (b) 6 : 3 : 2
(c) 3 : 6 : 2 (d) 6 : 2 : 3
21. The sum of three numbers is 98. If the ratio of the first to second number is 2 : 3 and that of the second to third is 5 : 8, then the second number is
[PYQ-May, 2025]

- (a) 20 (b) 30
(c) 48 (d) 58
22. The students in three classes are in the ratio 2 : 3 : 5. If 40 students are increased in each class the ratio changes to 4 : 5 : 7. Originally the total number of students was [MTP-June, 2024]
(a) 180 (b) 400
(c) 100 (d) 200
23. Suppose a father had a sum of ₹3,600 and he decided to divide this amount among his three sons Anil, Sunil and Nimal and such a way that 3 times Anil's share, 6 times Sunil's share and 8 times Nimal's share are all equal, then Anil's share is [Jan., 2025]
(a) ₹960 (b) ₹1,920
(c) ₹720 (d) ₹1,860
24. A vessel contained solution of acid and water in water was 64%. Four litres of the solution were taken out of the vessel and the same quantity of water was added. If the resulting solution contains 30% acid, the quantity (in litres) of the solution, in the beginning in the vessel is
[PYQ-July, 2021]
(a) 12 (b) 36
(c) 24 (d) 27

Indices

25. If $x = y^a$, $y = z^b$, $z = x^c$, then the value of abc is
[PYQ-June, 2023]
(a) 1 (b) 2
(c) 3 (d) 4
26. $\frac{x^{m+3n} \cdot x^{4m-9n}}{x^{6m-6n}}$ [PYQ-May, 2025]
(a) x^m (b) x^{-m}
(c) x^n (d) x^{-n}
27. Find the value of $\frac{3t^{-1}}{t^{\frac{1}{3}}}$
(a) $\frac{3}{t^3}$ (b) $\frac{3}{t^2}$
(c) $\frac{3}{t^3}$ (d) $\frac{3}{t^2}$

28. If $(25)^{150} = (25x)^{50}$, then the value of x will be
[MTP-June, 2022]

- (a) 5^3 (b) 5^4
(c) 5^2 (d) 5

29. Find the value of a from $(\sqrt{9})^{-8} \times (\sqrt{3})^{-5} = 3^a$
[PYQ-June, 2022, Dec., 2020]

- (a) $\frac{2}{21}$ (b) $\frac{21}{2}$
(c) $\frac{-21}{2}$ (d) $\frac{-2}{21}$

30. If $\left(\frac{x}{y}\right)^{a^2+4} = (x^{-1}y)^{-5a}$, then the value of a is
[PYQ-Jan., 2025]

- (a) $4, -1$ (b) $-4, 1$
(c) $-4, -1$ (d) $4, 1$

31. $(18)^{3.5} \div (27)^{3.5} \times 6^{3.5} = 2^x$, then the value of x is
[MTP-Sept., 2024]

- (a) 3.5 (b) 4.5
(c) 6 (d) 7

32. If $\frac{9^n \times 3^5 \times (27)^5}{3 \times (81)^4} = 27$, then find the value of n .

- (a) 2 (b) 0
(c) 3 (d) 4

33. The value of $\frac{(243)^{0.13} \times (243)^{0.07}}{(7)^{0.25} \times (49)^{0.075} \times (343)^{0.2}}$ is;

[MTP-Sept., 2024]

- (a) $\frac{3}{7}$ (b) $\frac{7}{3}$
(c) $1\frac{3}{7}$ (d) $2\frac{2}{7}$

34. If $\sqrt[3]{a} + \sqrt[3]{b} + \sqrt[3]{c} = 0$, then find the value of $\left(\frac{a+b+c}{3}\right)^3$
[PYQ-June, 2023]

- (a) abc (b) $9abc$
(c) $\frac{1}{abc}$ (d) $\frac{1}{9}abc$

35. If $4^x = 5^y = 20^z$, then z is equal to

- (a) xy (b) $\frac{(x+y)}{xy}$
(c) $\frac{1}{xy}$ (d) $\frac{xy}{(x+y)}$

36. If $2^x = 4^y = 8^z$ and $\frac{1}{2x} + \frac{1}{4y} + \frac{1}{6z} = \frac{24}{7}$, then the value of z is
[PYQ-June, 2024 Dec., 2023]

- (a) $\frac{7}{16}$ (b) $\frac{7}{32}$
(c) $\frac{7}{48}$ (d) $\frac{7}{64}$

37. The simplified value of $\frac{[5a^5b^2 \times 3(ab^3)^2]}{(15a^2b)}$ is
[PYQ-Jan., 2025]

- (a) a^7b^7 (b) a^5b^7
(c) a^5b^5 (d) a^7b^5

38. What is the value of

$$\left(\frac{x^b}{x^c}\right)^{b+c-a} \cdot \left(\frac{x^c}{x^a}\right)^{c+a-b} \cdot \left(\frac{x^a}{x^b}\right)^{a+b-c}$$

[PYQ-Sept., 2024]

- (a) x^{abc} (b) $x^{(a+b+c)}$
(c) -1 (d) 1

39. If $\left(\frac{y^a}{y^b}\right)^{a^2+ab+b^2} \cdot \left(\frac{y^b}{y^c}\right)^{b^2+bc+c^2} \cdot \left(\frac{y^c}{y^a}\right)^{c^2+ca+a^2}$ is equal

to
[MTP-June, 2022]

- (a) y (b) -1
(c) 1 (d) None of these

Logarithm

40. Find the value of $\log \frac{p^2}{qr} + \log \frac{q^2}{pr} + \log \frac{r^2}{pq}$

[PYQ-June, 2022]

- (a) 0 (b) 1
(c) $\log pqr$ (d) pqr

41. If $\log_a b = 3$ and $\log_b c = 2$, then $\log_a c$ is

[PYQ-June, 2024]

- (a) 5 (b) 6
(c) 10 (d) 4

42. The value of $[\log_{10}(5 \log_{10} 100)]^2$ is

[PYQ-June 2023]

- (a) 1 (b) 2
(c) 10 (d) 25

43. If $\log x = \log 5 + 2 \log 3 - \frac{1}{2} \log 25$, then the value of x is
[PYQ-May, 2025]

- (a) 8 (b) 9
 (c) 10 (d) None of these

44. If $\log_a \sqrt{3} = \frac{1}{6}$, find the value of a .
[PYQ-June, 2022, Dec., 2020]

- (a) 3 (b) 9
 (c) 27 (d) 81

45. Given that $\log_{10} 2 = x$ and $\log_{10} 3 = y$, then the value of $\log_{10} 60$ is expressed as

[PYQ-Jan., 2025]

- (a) $x - y + 1$ (b) $x + y + 1$
 (c) $x - y - 1$ (d) None of these

46. Find the value of $\log(x^6)$ if $\log x + 2 \log(x^2) + 3 \log(x^3) = 14$
[PYQ-Dec., 2025]

- (a) 3 (b) 4
 (c) 5 (d) 6

47. If $\log_{10} x = m + n - 1$ and $\log_{10} y = m - n$, then the value of $\log_{10} \left(\frac{100x}{y^2} \right)$ expressed in terms of m and n is
[PYQ-June, 2023]

- (a) $1 - m + 3n$ (b) $m - 1 + 3n$
 (c) $m + 3n + 1$ (d) $m^2 - n^2$

48. $\frac{1}{\log_{xy}(xyz)} + \log_{xyz} yz + \frac{1}{\log_{xz}(xyz)} = ?$

[PYQ-Sept., 2024]

- (a) 1 (b) 2
 (c) 3 (d) None of these

49. $\log_4(x^2 + x) - \log_4(x + 1) = 2$. Find x .

[PYQ-May, 2025]

- (a) 16 (b) 0
 (c) -1 (d) None of these

50. $\log_2 \log_2 \log_4 256 + 2 \log_{\sqrt{2}} 2$ is equal to

[PYQ-Sept., 2024]

- (a) 2 (b) 3
 (c) 5 (d) 7

51. The value of $\log_5 \left(1 + \frac{1}{5} \right) + \log_5 \left(1 + \frac{1}{6} \right) + \dots +$

$$\log_5 \left(1 + \frac{1}{624} \right)$$

- (a) 2
 (b) 3
 (c) 5
 (d) Cannot be determined

52. If $\log \frac{a+b}{4} = \frac{1}{2} (\log a + \log b)$, then the value of

$$\frac{a}{b} + \frac{b}{a}$$
 will be

[PYQ-May, 2025]

- (a) 12 (b) 14
 (c) 16 (d) 8

53. If $\log_a(ab) = x$, then $\log_b(ab)$ is

[PYQ-June, 2021]

- (a) $\frac{1}{x}$ (b) $\frac{x}{1+x}$
 (c) $\frac{x}{x-1}$ (d) None of these

54. If $x = \log_{24} 12$, $y = \log_{36} 24$, $z = \log_{48} 36$, then $xyz + 1 = ?$
[MTP-June, 2022]

- (a) $2xy$ (b) $2xz$
 (c) $2yz$ (d) 2

ANSWER KEY

- | | | | | | | | | | |
|---------|---------|---------|---------|---------|---------|---------|---------|---------|---------|
| 1. (b) | 2. (a) | 3. (b) | 4. (d) | 5. (b) | 6. (b) | 7. (a) | 8. (c) | 9. (a) | 10. (a) |
| 11. (a) | 12. (c) | 13. (b) | 14. (b) | 15. (c) | 16. (a) | 17. (d) | 18. (a) | 19. (b) | 20. (d) |
| 21. (b) | 22. (d) | 23. (b) | 24. (c) | 25. (a) | 26. (b) | 27. (a) | 28. (b) | 29. (c) | 30. (d) |
| 31. (d) | 32. (b) | 33. (a) | 34. (a) | 35. (d) | 36. (c) | 37. (b) | 38. (d) | 39. (c) | 40. (a) |
| 41. (b) | 42. (a) | 43. (b) | 44. (c) | 45. (b) | 46. (d) | 47. (a) | 48. (b) | 49. (a) | 50. (c) |
| 51. (b) | 52. (b) | 53. (c) | 54. (c) | | | | | | |

HINTS & SOLUTIONS

1. (b) We know,

$p : q = r : s$ implies $q : s : r$, is the process of Invertendo.

2. (a) Given: $\frac{3x-2}{5x+6}$ is the duplicate ratio of $\frac{2}{3}$

We know that, $a^2 : b^2$ is the duplicate ratio of $a : b$.

$$\Rightarrow \text{The duplicate ratio of } \frac{2}{3} = \frac{(2)^2}{(3)^2} = \frac{4}{9}$$

According to the given problem, we have

$$\frac{3x-2}{5x+6} = \frac{4}{9}$$

On cross multiplication, we get

$$9(3x-2) = 4(5x+6)$$

$$\Rightarrow 27x - 18 = 20x + 24$$

$$\Rightarrow 27x - 20x = 24 + 18$$

$$\Rightarrow 7x = 42$$

$$\Rightarrow x = 6$$

Therefore, the value of x is 6.

Hence, the correct option is (a).

3. (b) Given; $\frac{p}{q} = 7$

$$\Rightarrow \frac{p}{q} = \frac{7}{1}$$

Let $p = 7x$ and $q = x$, then

$$\frac{p+q}{p-q} = \frac{7x+x}{7x-x}$$

$$\Rightarrow \frac{p+q}{p-q} = \frac{8x}{6x}$$

$$\Rightarrow \frac{p+q}{p-q} = \frac{8}{6} = \frac{4}{3}$$

4. (d) Given; $x : y = 7 : 8$

Let $x = 7a$ and $y = 8a$, then

$$\frac{6x+5y}{4x+3y}$$

$$= \frac{6(7a)+5(8a)}{4(7a)+3(8a)}$$

$$= \frac{42a+40a}{28a+24a}$$

$$\begin{aligned} &= \frac{82a}{52a} \\ &= \frac{41}{26} \\ &= 41 : 26 \end{aligned}$$

5. (b) Given; $2 : x = 1 : 2$

$$\Rightarrow \frac{2}{x} = \frac{1}{2}$$

$$\Rightarrow x = 4$$

Also, $x : y = 4 : 6$

$$\frac{x}{y} = \frac{4}{6}$$

$$\Rightarrow \frac{4}{y} = \frac{4}{6}$$

$$\Rightarrow y = 6$$

6. (b) Given, $x : y = 2 : 3$

Let $x = 2a$ and $y = 3a$, then

$$(5x+2y) : (3x-y)$$

$$= \frac{5x+2y}{3x-y}$$

$$= \frac{5(2a)+2(3a)}{3(2a)-3a}$$

$$= \frac{10a+6a}{6a-3a}$$

$$= \frac{16a}{3a} = \frac{16}{3}$$

$$= 16 : 3$$

7. (a) Given, $A : B = 2 : 5$

Let $A = 2x$ and $B = 5x$

Thus, $(10A+3B) : (5A+2B)$

$$= \frac{10A+3B}{5A+2B}$$

$$= \frac{10(2x)+3(5x)}{5(2x)+2(5x)}$$

$$= \frac{20x+15x}{10x+10x}$$

$$\begin{aligned} &= \frac{35x}{20x} = \frac{35}{20} \\ &= 7 : 4 \end{aligned}$$

8. (c) Given that, Salaries of A, B, C are in the ratio 2 : 3 : 5.

Let $A = 2K$, $B = 3K$ and $C = 5K$

After the increment of 15%, 10% and 20%, then

$$A's \text{ new salary} = 2K + 15\% \text{ of } 2K = \frac{115}{100} \text{ of } 2K = \left(\frac{115}{100} \times 2K\right) = \frac{23K}{10}$$

$$B's \text{ new salary} = \frac{110}{100} \text{ of } 3K = \left(\frac{110}{100} \times 3K\right) = \frac{33K}{10}$$

$$C's \text{ new salary} = \frac{120}{100} \text{ of } 5K = \left(\frac{120}{100} \times 5K\right) = 6K$$

$$\therefore \text{New Ratio} = \left(\frac{23K}{10} : \frac{33K}{10} : 6K\right) = 23 : 33 : 60$$

9. (a) Given, Ratio of 25 paise, 10 paise and 5 paise coins = 3 : 2 : 1

Total value = ₹40

Let the number of 25 paise coins, 10 paise coins and 5 paise coins be $3x$, $2x$ and x respectively.

Then, the value = $0.25 \times 3x + 0.10 \times 2x + 0.05 \times x$

$$\Rightarrow 0.75x + 0.20x + 0.05x = 40$$

$$\Rightarrow x = 40$$

Therefore, the number of 5 paise coins = $x = 40$

10. (a) Let the number of 1 rupee coins = x , then

Number of 50 paise coins = $4x$

Number of 25 paise coins = $2x$

Since, total amount = ₹56

Thus, $1 \times x + 0.50 \times 4x + 0.25 \times 2x = 56$

$$\Rightarrow x + 2x + 0.5x = 56$$

$$\Rightarrow 3.5x = 56$$

$$\Rightarrow x = 16$$

Therefore, the number of 50 paise coins = $4x$
 $4(16) = 64$

11. (a) We know,

Sub-duplicate of 4 : a is $\sqrt{4} : \sqrt{a} = 2 : \sqrt{a}$

Since, ratio compounded of 4 : 5 and sub-duplicate of 4 : $a = 8 : 15$ i.e.,

$$\frac{4}{5} \times \frac{2}{\sqrt{a}} = \frac{8}{15}$$

$$\Rightarrow \frac{8}{5} = \frac{8\sqrt{a}}{15}$$

$$\Rightarrow \sqrt{a} = 3$$

$$\Rightarrow a = 3^2$$

$$\Rightarrow a = 9$$

12. (c) Let the income of A and B be $5x$ and $4x$ respectively.

We know,

Expenditure = Income - Savings

According to question, we have

$$\frac{5x - 1600}{4x - 1600} = \frac{3}{2}$$

$$\Rightarrow 2(5x - 1600) = 3(4x - 1600)$$

$$\Rightarrow 10x - 3200 = 12x - 4800$$

$$\Rightarrow 12x - 10x = 4800 - 3200$$

$$\Rightarrow 2x = 1600$$

$$\Rightarrow x = 800$$

Therefore, the income of A will be $5(800) = ₹4000$

13. (b) Let b be the mean proportional between 8 and 32.

Then, $b^2 = 8 \times 32$

$$\Rightarrow b = \sqrt{8 \times 32}$$

$$\Rightarrow b = \sqrt{8 \times 8 \times 4}$$

$$\Rightarrow b = 16$$

14. (b) Let the third proportional be c , then

$$49 : 21 = 21 : x$$

$$\Rightarrow \frac{49}{21} = \frac{21}{x}$$

$$\Rightarrow (21)^2 = 49x$$

$$\Rightarrow x = \frac{(21)^2}{49} \Rightarrow x = 9$$

15. (c) Let the fourth proportional to x , $2x$, $(x + 1)$ be y , then

$$\frac{x}{2x} = \frac{x+1}{y}$$

$$\Rightarrow \frac{1}{2} = \frac{x+1}{y}$$

$$\Rightarrow y = 2(x + 1)$$

$$\Rightarrow y = 2x + 2$$

16. (a) Let the mean proportional between $12x^2$ and $27y^2$ be ' b ', then

$$b^2 = 12x^2 \times 27y^2$$

$$\Rightarrow b^2 = 324x^2y^2$$

$$\Rightarrow b = \sqrt{324x^2y^2}$$

$$\Rightarrow b = 18xy$$

17. (d) Given; D is 50% more than E

Let $E = x$, then

$$D = x + 50\% \text{ of } x$$

$$\Rightarrow D = x + 0.5x$$

$$\Rightarrow D = 1.5x$$

Also, $A : B = 3 : 4$, $B : C = 7 : 9$, $C : D = 2 : 3$

Therefore, the ratio between A and E is given by

$$\frac{A}{E} = \frac{A}{B} \times \frac{B}{C} \times \frac{C}{D} \times \frac{D}{E}$$

$$\Rightarrow \frac{A}{E} = \frac{3}{4} \times \frac{7}{9} \times \frac{2}{3} \times \frac{1.5x}{x}$$

$$\Rightarrow \frac{A}{E} = \frac{7}{12}$$

18. (a) Given, $\frac{1}{2}$, $\frac{1}{3}$, $\frac{1}{5}$ and $\frac{1}{x}$ are in proportion, then

$$\frac{\frac{1}{2}}{\frac{1}{3}} = \frac{\frac{1}{5}}{\frac{1}{x}}$$

$$\Rightarrow \frac{3 \times 1}{2 \times 1} = \frac{x \times 1}{5 \times 1}$$

$$\Rightarrow \frac{3}{2} = \frac{x}{5} \Rightarrow x = \frac{15}{2}$$

19. (b) Given, Ratio of shares of wife, son and daughter = $3 : 2 : 1$

Total assets value = ₹1,48,200

$$\text{Therefore, share of son} = \frac{2}{3+2+1} \times 148200$$

$$= \frac{2}{6} \times 148200$$

$$= \frac{1}{3} \times 148200 = 49400$$

Hence, the share of his son is ₹49,400.

20. (d) According to the question, we have

$$X = 3Y \text{ and } Y = \frac{2}{3}Z$$

$$\Rightarrow \frac{X}{Y} = \frac{3}{1} \text{ and } \frac{Y}{Z} = \frac{2}{3}$$

$$\Rightarrow \frac{X}{Y} = \frac{3}{1} \times \frac{2}{2} \text{ and } \frac{Y}{Z} = \frac{2}{3}$$

$$\Rightarrow \frac{X}{Y} = \frac{6}{2} \text{ and } \frac{Y}{Z} = \frac{2}{3}$$

$$\Rightarrow X : Y : Z = 6 : 2 : 3$$

21. (b) Let the number be x, y and z .

According to question, we have

$$x : y = 2 : 3 \text{ and } y : z = 5 : 8$$

$$\Rightarrow \frac{x}{y} = \frac{2}{3} \times \frac{5}{5} \text{ and } \frac{y}{z} = \frac{5}{8} \times \frac{3}{3}$$

$$\Rightarrow \frac{x}{y} = \frac{10}{15} \text{ and } \frac{y}{z} = \frac{15}{24}$$

$$\Rightarrow x : y : z = 10 : 15 : 24$$

Sum of the ratios = $10 + 15 + 24 = 48$

Therefore, the second number $\frac{15}{48} \times 98 = 30$

22. (d) Given, Ratio of students in three classes = $2 : 3 : 5$

Let the students in three classes be $2x, 3x$ and $5x$ respectively.

According to question,

$$(2x + 40) : (3x + 40) : (5x + 40) = 4 : 5 : 7$$

$$\Rightarrow \frac{2x + 40}{3x + 40} = \frac{4}{5}$$

$$\Rightarrow 5(2x + 40) = 4(3x + 40)$$

$$\Rightarrow 10x + 200 = 12x + 160$$

$$\Rightarrow 2x = 40$$

$$\Rightarrow x = 20$$

Therefore, the total students originally were,

$$2x + 3x + 5x = 10x = 10(20) = 200$$

23. (b) Since, 3 times Anil's share, 6 times Sunil's share and 8 times Nimal's share are all equal i.e.,

$$3A = 6B = 8C$$

$$\Rightarrow \frac{3A}{24} = \frac{6B}{24} = \frac{8C}{24}$$

$$\Rightarrow \frac{A}{8} = \frac{B}{4} = \frac{C}{3}$$

Therefore, Anil's share is given by:

$$= \frac{8}{8+4+3} \times 3600$$

$$= \frac{8}{15} \times 3600 = ₹1,920$$

24. (c) Let the quantity of mixture be x , then

Quantity of acid = $(100 - 64)\%$ of $x = 0.36x$

Now, quantity of acid in 4 litres of mixture = $4 \times 36\% = 1.44$

Since, 4 litres of the solution were taken out of the vessel, thus

$$\text{Remaining acid} = 0.36x - 1.44$$

Also, same quantity of water was added, thus

$$\text{Total quantity} = x - 4 + 4 = x \text{ litres}$$

Therefore, the percentage of acid is

$$\frac{0.36x - 1.44}{x} \times 100 = 30$$

$$\Rightarrow 0.36x - 1.44 = 0.3x$$

$$\Rightarrow 0.06x = 1.44 \Rightarrow x = 24 \text{ litres}$$

25. (a) Given, $x = y^a$, $y = z^b$, $z = x^c$

$$\Rightarrow x = y^a \text{ \& } y = z^b$$

$$\Rightarrow x = (z^b)^a$$

$$\Rightarrow x = z^{ab}$$

$$\text{Also, } z = x^c$$

$$\Rightarrow x = (x^c)^{ab}$$

$$\Rightarrow x = x^{abc}$$

$$\Rightarrow abc = 1$$

26. (b) $\frac{x^{m+3n} \cdot x^{4m-9n}}{x^{6m-6n}}$

$$= \frac{x^{m+3n+4m-9n}}{x^{6m-6n}}$$

$$= \frac{x^{5m-6n}}{x^{6m-6n}}$$

$$= x^{5m-6n-(6m-6n)} = x^{-m}$$

27. (a) To simplify: $\frac{3t^{-1}}{t^{\frac{1}{3}}}$

We know that, $t^{\frac{1}{3}}$

$$\frac{a^m}{a^n} = a^{m-n}$$

$$\therefore \frac{3t^{-1}}{t^{\frac{1}{3}}} = 3t^{-1-\left(\frac{1}{3}\right)}$$

$$= 3t^{-1+\frac{1}{3}} = 3t^{-\frac{2}{3}}$$

$$= \frac{3}{t^{\frac{2}{3}}}$$

Hence, the correction answer is option (a) i.e.,

$$\frac{3}{t^{\frac{2}{3}}}$$

28. (b) Given, $(25)^{150} = (25x)^{50}$

$$\Rightarrow (5^2)^{150} = (5^2x)^{50}$$

$$\Rightarrow 5^{300} = 5^{100}x^{50}$$

$$\Rightarrow x = 5^{\frac{200}{50}}$$

$$\Rightarrow x = 5^4$$

29. (c) Given, $(\sqrt{9})^{-8} \times (\sqrt{3})^{-5} = 3^a$

$$\Rightarrow (3)^{-8} \times \left(3^{\frac{1}{2}}\right)^{-5} = 3^a$$

$$\Rightarrow (3)^{-8} \times 3^{-\frac{5}{2}} = 3^a$$

$$\Rightarrow (3)^{-8-\frac{5}{2}} = 3^a$$

$$\Rightarrow (3)^{\frac{21}{2}} = 3^a$$

$$\Rightarrow a = -\frac{21}{2}$$

30. (d) Given, $\left(\frac{x}{y}\right)^{a^2+4} = (x^{-1}y)^{-5a}$

$$\Rightarrow \left(\frac{x}{y}\right)^{a^2+4} = \left(\frac{y}{x}\right)^{-5a}$$

$$\Rightarrow \left(\frac{x}{y}\right)^{a^2+4} = \left(\frac{x}{y}\right)^{5a}$$

$$\Rightarrow a^2 + 4 = 5a$$

$$\Rightarrow a^2 - 5a + 4 = 0$$

$$\Rightarrow a^2 - 4a - a + 4 = 0$$

$$\Rightarrow a(a-4) - 1(a-4) = 0$$

$$\Rightarrow (a-1)(a-4) = 0$$

$$\Rightarrow a = 1, 4$$

31. (d) $(18)^{3.5} \div (27)^{3.5} \times 6^{3.5} = 2^x$

$$\Rightarrow \frac{(18)^{3.5}}{(27)^{3.5}} \times 6^{3.5} = 2^x$$

$$\Rightarrow \left(\frac{18 \times 6}{27}\right)^{3.5} = 2^x$$

$$\Rightarrow (4)^{3.5} = 2^x$$

$$\Rightarrow (2)^7 = 2^x$$

$$\Rightarrow x = 7$$

Therefore, the value of x is 7.

32. (b) Given, $\frac{9^n \times 3^5 \times (27)^5}{3 \times (81)^4} = 27$

$$\Rightarrow \frac{(3^2)^n \times 3^5 \times (3^3)^5}{3 \times (3^4)^4} = (3^3)$$

$$\Rightarrow 3^{2n} \times 3^5 \times 3^{15} = 3^3 \times 3^1 \times 3^{16}$$

$$\Rightarrow 3^{2n+20} = 3^{20}$$

$$\Rightarrow 2n + 20 = 20$$

$$\Rightarrow 2n = 0$$

$$\Rightarrow n = 0$$

33. (a) $\frac{(243)^{0.13} \times (243)^{0.07}}{(7)^{0.25} \times (49)^{0.075} \times (343)^{0.2}}$

$$= \frac{(3^5)^{0.13} \times (3^5)^{0.07}}{(7)^{0.25} \times (7^2)^{0.075} \times (7^3)^{0.2}}$$

$$= \frac{3^{0.65} \times 3^{0.35}}{7^{0.25} \times 7^{0.15} \times 7^{0.6}}$$

$$= \frac{3^{0.65+0.35}}{7^{0.25+0.15+0.6}}$$

$$= \frac{3}{7}$$

34. (a) $\sqrt[3]{a} + \sqrt[3]{b} + \sqrt[3]{c} = 0$

We know, If $p + q + r = 0$

Then, $p^3 + q^3 + r^3 = 3pqr$

Therefore,

$$\left(a^{\frac{1}{3}}\right)^3 + \left(b^{\frac{1}{3}}\right)^3 + \left(c^{\frac{1}{3}}\right)^3 = 3\left(a^{\frac{1}{3}}\right)\left(b^{\frac{1}{3}}\right)\left(c^{\frac{1}{3}}\right)$$

$$\Rightarrow a + b + c = 3(abc)^{\frac{1}{3}}$$

$$\Rightarrow (a + b + c)^3 = 27abc$$

$$\Rightarrow \left(\frac{a+b+c}{3}\right) = abc$$

35. (d) Given, $4^x = 5^y = 20^z$

Let $4^x = 5^y = 20^z = k$

$$\Rightarrow 4 = k^{1/x}, 5 = k^{1/y} \text{ and } 20 = k^{1/z}$$

We know,

$$20 = 4 \times 5$$

$$\Rightarrow k^{\frac{1}{z}} = k^{\frac{1}{x}} \times k^{\frac{1}{y}}$$

$$\Rightarrow k^{\frac{1}{z}} = k^{\frac{1}{x} + \frac{1}{y}}$$

$$\Rightarrow \frac{1}{z} = \frac{1}{x} + \frac{1}{y}$$

$$\Rightarrow \frac{1}{z} = \frac{y+x}{xy}$$

$$\Rightarrow z = \frac{xy}{x+y}$$

36. (c) Given, $2^x = 4^y = 8^z$

$$\Rightarrow 2^x = (2^2)^y = (2^3)^z$$

$$\Rightarrow 2^x = 2^{2y} = 2^{3z}$$

$$\Rightarrow x = 2y = 3z$$

.....(i)

Also, $\frac{1}{2x} + \frac{1}{4y} + \frac{1}{6z} = \frac{24}{7}$

$$\Rightarrow \frac{1}{2(3z)} + \frac{1}{2(3z)} + \frac{1}{6z} = \frac{24}{7}$$

$$\Rightarrow \frac{1}{6z} + \frac{1}{6z} + \frac{1}{6z} = \frac{24}{7}$$

$$\Rightarrow \frac{3}{6z} = \frac{24}{7}$$

$$\Rightarrow \frac{1}{2z} = \frac{24}{7}$$

$$\Rightarrow z = \frac{7}{48}$$

37. (b) $\frac{[5a^5b^2 \times 3(ab^3)^2]}{(15a^2b)}$

$$\frac{5a^5b^2 \times 3a^2b^6}{15a^2b}$$

$$\frac{15a^7b^8}{15a^2b} = a^5b^7$$

38. (d) $\left(\frac{x^b}{x^c}\right)^{b+c-a} \cdot \left(\frac{x^c}{x^a}\right)^{c+a-b} \cdot \left(\frac{x^a}{x^b}\right)^{a+b-c}$

$$= (x^{b-c})^{b+c-a} \cdot (x^{c-a})^{c+a-b} \cdot (x^{a-b})^{a+b-c}$$

$$= x^{b^2-bc-ab-bc-c^2+ac+c^2+ac-bc-ac-a^2+ab-ac-ab-b^2+bc}$$

$$= x^0 = 1$$

'or' cyclic order trick

Since, $(b-c)(b+c-a) + (c-a)(c+a-b) + (a-b)(a+b-c) = 0$

$$(a+b-c) = 0$$

Thus, $\left(\frac{x^b}{x^c}\right)^{b+c-a} \cdot \left(\frac{x^c}{x^a}\right)^{c+a-b} \cdot \left(\frac{x^a}{x^b}\right)^{a+b-c} = x^0 = 1$

$$\begin{aligned}
 39. (c) & \left(\frac{y^a}{y^b}\right)^{b^2+ab+b^2} \cdot \left(\frac{y^b}{y^c}\right)^{b^2+bc+c^2} \cdot \left(\frac{y^c}{y^a}\right)^{c^2+ca+a^2} \\
 & \Rightarrow (y^{a-b})^{a^2+ab+b^2} \times (y^{b-c})^{b^2+bc+c^2} \times (y^{c-a})^{c^2+ca+a^2} \\
 & \Rightarrow y^{(a-b)(a^2+ab+b^2)} \times y^{(b-c)(b^2+bc+c^2)} \times y^{(c-a)(c^2+ca+a^2)} \\
 & \Rightarrow y^{a^3-b^3} \times y^{b^3-c^3} \times y^{c^3-a^3} \\
 & \Rightarrow y^{a^3-b^3+b^3-c^3+c^3-a^3} \\
 & \Rightarrow y^0 = 1
 \end{aligned}$$

$$\begin{aligned}
 40. (a) & \log \frac{p^2}{qr} + \log \frac{q^2}{pr} + \log \frac{r^2}{pq} \\
 & \log \left(\frac{p^2}{qr} \cdot \frac{q^2}{pr} \cdot \frac{r^2}{pq} \right) \\
 & = \log(1) = 0
 \end{aligned}$$

$$\begin{aligned}
 41. (b) & \text{ Given, } \log_a b = 3 \text{ and } \log_b c = 2 \\
 & \Rightarrow \log_a b \times \log_a c \\
 & \Rightarrow \frac{\log b}{\log a} \times \frac{\log c}{\log a} \\
 & \Rightarrow \frac{\log c}{\log a} \\
 & \Rightarrow \log_a c = \log_a b \times \log_a c \\
 & \Rightarrow \log_a c = 3 \times 2 \\
 & \Rightarrow \log_a c = 6
 \end{aligned}$$

$$\begin{aligned}
 42. (a) & [\log_{10} (5 \log_{10} 100)]^2 \\
 & = [\log_{10} (5 \log_{10} 10^2)]^2 \\
 & = [\log_{10} (5 \times 2 \log_{10} 10)]^2 \\
 & = [\log_{10} (5 \times 2(1))]^2 \\
 & = [\log_{10} (10)]^2 \\
 & = (1)^2 = 1
 \end{aligned}$$

$$\begin{aligned}
 43. (b) & \text{ Given, } \log x = \log 5 + 2 \log 3 - \frac{1}{2} \log 25 \\
 & \Rightarrow \log x = \log 5 + \log 3^2 - \log(25)^{1/2} \\
 & \Rightarrow \log x = \log 5 + \log 9 - \log 5 \\
 & \Rightarrow \log x = \log 9 \\
 & \Rightarrow x = 9
 \end{aligned}$$

$$\begin{aligned}
 44. (c) & \text{ Given, } \log_a \sqrt{3} = \frac{1}{6} \\
 & \Rightarrow \log_a 3^{\frac{1}{2}} = \frac{1}{6}
 \end{aligned}$$

$$\Rightarrow \frac{1}{2} \log_a 3 = \frac{1}{6}$$

$$\Rightarrow \log_a 3 = \frac{1}{3}$$

$$\Rightarrow 3 = a^{\frac{1}{3}}$$

$$\Rightarrow a = 3^3$$

$$\Rightarrow a = 27$$

$$45. (b) \text{ Given, } \log_{10} 2 = x \text{ and } \log_{10} 3 = y$$

We know,

$$\begin{aligned}
 \log_{10} 60 & = \log_{10} (2 \times 3 \times 10) \\
 & = \log_{10} 2 + \log_{10} 3 + \log_{10} 10 \\
 & = x + y + 1
 \end{aligned}$$

$$46. (d) \text{ Given, } \log x + 2 \log (x^2) + 3 \log (x^3) = 14$$

$$\Rightarrow \log x + 2 \times 2 \log (x) + 3 \times 3 \log (x) = 14$$

$$\Rightarrow \log x + 4 \log x + 9 \log x = 14$$

$$\Rightarrow 14 \log x = 14$$

$$\Rightarrow \log x = 1$$

$$\text{Therefore, } \log (x^6) = 6 \log x = 6(1) = 6$$

$$47. (a) \text{ Given, } \log_{10} x = m + n - 1 \text{ and } \log_{10} y = m - n$$

Now, the given expression can be simplified as;

$$\log_{10} \left(\frac{100x}{y^2} \right) = \log_{10}(100) + \log_{10}(x) - \log_{10}(y^2)$$

$$\Rightarrow \log_{10} \left(\frac{100x}{y^2} \right) = \log_{10}(10^2) + \log_{10}(x) - \log_{10}(y^2)$$

$$\Rightarrow \log_{10} \left(\frac{100x}{y^2} \right) = 2\log_{10}(10) + \log_{10}(x) - 2\log_{10}(y)$$

$$\Rightarrow \log_{10} \left(\frac{100x}{y^2} \right) = 2(1) + (m + n - 1) - 2(m - n)$$

$$\Rightarrow \log_{10} \left(\frac{100x}{y^2} \right) = 2 + m + n - 1 - 2m + 2n$$

$$\Rightarrow \log_{10} \left(\frac{100x}{y^2} \right) = 1 - m + 3n$$

$$48. (b) \frac{1}{\log_{xy}(xyz)} + \log_{xyz} yz + \frac{1}{\log_{xz}(xyz)}$$

$$= \log_{xyz}(xy) + \log_{xyz} yz + \log_{xyz}(xz)$$

$$= \log_{xyz}(xy \times yz \times xz)$$

$$= \log_{xyz}(xyz)^2$$

$$= 2\log_{xyz}(xyz)$$

$$= 2(1) = 2$$

49. (a) $\log_4 (x^2 + x) - \log_4 (x + 1) = 2$

$$\Rightarrow \log_4 \frac{(x^2 + x)}{(x + 1)} = 2$$

$$\Rightarrow \log_4 \frac{x(x + 1)}{x + 1} = 2$$

$$\Rightarrow \log_4 x = 2 \Rightarrow x = 4^2 \Rightarrow x = 16$$

50. (c) $\log_2 \log_2 \log_4 256 + 2 \log_{\sqrt{2}} 2$

$$= \log_2 \log_2 \log_4 4^4 + 2 \log_{\frac{1}{2}} 2$$

$$= \log_2 \log_2 (4 \log_4 4) + \frac{2}{\frac{1}{2}} \log_2 2$$

$$= \log_2 \log_2 (2^2) + 4(1)$$

$$= \log_2 2 + 4 = 1 + 4 = 5$$

51. (b) $\log_5 \left(1 + \frac{1}{5}\right) + \log_5 \left(1 + \frac{1}{6}\right) + \dots +$

$$\log_5 \left(1 + \frac{1}{624}\right)$$

$$= \log_5 \left(\frac{6}{5}\right) + \log_5 \left(\frac{7}{6}\right) + \dots + \log_5 \left(\frac{625}{624}\right)$$

$$= \log_5 \left(\frac{6}{5} \times \frac{7}{6} \times \dots \times \frac{625}{624}\right)$$

$$= \log_5 \left(\frac{625}{5}\right)$$

$$= \log_5 (125) = \log_5 (5^3) = 3$$

52. (b) Given, $\log \frac{a+b}{4} = \frac{1}{2}(\log a + \log b)$

$$\Rightarrow \log \frac{a+b}{4} = \frac{1}{2}(\log ab)$$

$$\Rightarrow \log \frac{a+b}{4} = \log(ab)^{\frac{1}{2}}$$

$$\Rightarrow \frac{a+b}{4} = (ab)^{\frac{1}{2}}$$

$$\Rightarrow \left(\frac{a+b}{4}\right)^2 = ab$$

$$\Rightarrow \frac{a^2 + b^2 + 2ab}{16} = ab$$

$$\Rightarrow a^2 + b^2 + 2ab = 16ab$$

$$\Rightarrow a^2 + b^2 = 14ab$$

$$\Rightarrow \frac{a^2 + b^2}{ab} = 14 \Rightarrow \frac{a}{b} + \frac{b}{a} = 14$$

53. (c) Given, $\log_a (ab) = x$

$$\Rightarrow \frac{\log(ab)}{\log a} = x$$

$$\Rightarrow \frac{\log a + \log b}{\log a} = x$$

$$\Rightarrow 1 + \frac{\log b}{\log a} = x$$

$$\Rightarrow \frac{\log b}{\log a} = x - 1$$

.....(i)

Therefore,

$$\log_b (ab) = \frac{\log ab}{\log b}$$

$$\Rightarrow \log_b (ab) = \frac{\log a + \log b}{\log b}$$

$$\Rightarrow \log_b (ab) = \frac{\log a}{\log b} + 1$$

$$\Rightarrow \log_b (ab) = \frac{1}{x-1} + 1 \dots \dots \text{(from i)}$$

$$\Rightarrow \log_b (ab) = \frac{1+x-1}{x-1} \Rightarrow \log_b (ab) = \frac{x}{x-1}$$

54. (c) Given, $x = \log_{24} 12, y = \log_{36} 24, z = \log_{48} 36$

Thus, $xyz + 1$

$$= \frac{\log 12}{\log 24} \times \frac{\log 24}{\log 36} \times \frac{\log 36}{\log 48} + 1$$

$$= \frac{\log 12}{\log 48} + 1$$

$$= \log_{48} 12 + \log_{48} 48$$

$$= \log_{48} (12 \times 48)$$

$$= \log_{48} (576)$$

$$= \log_{48} (24)^2$$

$$= 2 \log_{48} (24)$$

For option (c): $2yz$

$$= 2(\log_{36} 24)(\log_{48} 36)$$

$$= 2 \times \frac{\log_{10} 24}{\log_{10} 36} \times \frac{\log_{10} 36}{\log_{10} 48}$$

$$= 2 \times \frac{\log_{10} 24}{\log_{10} 48}$$

$$= 2 \log_{48} (24)$$

Therefore, $xyz + 1 = 2yz$



Chapter Wrap-Up Test

Ready to test your knowledge?

You've got 15 questions and 20 minutes - Go for it!

1. The ratio of two quantities is 11 : 13. If the consequent of its inverse ratio is 11, then the antecedent is

(a) 11 (b) $\sqrt{11}$ (c) 13 (d) $\sqrt{13}$

2. If $\frac{3x-2}{5x+6}$ is the duplicate ratio of $\frac{2}{3}$, then the value of x is

(a) 1 (b) 3 (c) 6 (d) 10

3. If $x : y = 2 : 3$, then $(5x + 2y) : (3x - y) =$

(a) 19 : 3 (b) 16 : 3
(c) 7 : 2 (d) 7 : 3

4. If $\log(2a - 3b) = \log a - \log b$, then $a = ?$

(a) $\frac{3b^2}{2b-1}$ (b) $\frac{3b}{2b-1}$

(c) $\frac{b^2}{2b+1}$ (d) $\frac{3b^2}{2b+1}$

5. If $(25)^{150} = (25x)^{50}$, then the value of x will be

(a) 5^3 (b) 5^4 (c) 5^2 (d) 5

6. The expenditure and savings of a person are in the ratio 4 : 1. If his savings are increased by 25% of his income, then what is the new ratio of his expenditure and savings?

(a) 1 : 3 (b) 11 : 9
(c) 3 : 7 (d) 10 : 21

7. The value of $\frac{64(b^4 a^3)^6}{[4(a^3 b)^2 \times (ab)^2]}$ is

(a) $16a^{10}b^{20}$ (b) $4a^{20}b^{20}$
(c) $8a^{10}b^{20}$ (d) $4a^{10}b^{20}$

8. A box contains ₹56 in the form of coins of one rupee, 50 paise and 25 paise. The number of 50 paise coin is double the number of 25 paise coins and four times the numbers of the one rupee coins. The

numbers of 50 paise coins in the box is.

(a) 64 (b) 32 (c) 16 (d) 4

9. The expenditures and savings of a person are in the ratio 4 : 1. If his savings are increased by 25% of his income, then what is the new ratio of his expenditure and savings?

(a) 1 : 3 (b) 11 : 9
(c) 3 : 7 (d) 10 : 21

10. If $4^x = 5^y = 20^z$ then z is equal to:

(a) xy (b) $\frac{x+y}{xy}$

(c) $\frac{1}{xy}$ (d) $\frac{xy}{x+y}$

11. A person has asset worth of ₹1,48,200. He wish to divide it amongst his wife, son and daughter in the ratio 3 : 2 : 1 respectively. From this assets, share of his son will be:

(a) ₹24,700 (b) ₹49,400
(c) ₹74,100 (d) ₹37,050

12. If $\log_a \sqrt{3} = \frac{1}{6}$, find the value of a.

(a) 9 (b) 81 (c) 27 (d) 3

13. X, Y, Z together start a business, if X invests 3 times as much as Y invests two third of what Z invests, then the ratio of capitals of X, Y, Z is

(a) 3 : 9 : 2 (b) 6 : 3 : 2
(c) 3 : 6 : 2 (d) 6 : 2 : 3

14. If $\left(\frac{y^a}{y^b}\right)^{a^2+ab+b^2} \times \left(\frac{y^b}{y^c}\right)^{b^2+bc+c^2} \times \left(\frac{y^c}{y^a}\right)^{c^2+ca+a^2}$

is equal to

(a) y (b) -1
(c) 1 (d) None of these

15. If $\log_3 4 \cdot \log_4 5 \cdot \log_5 6 \cdot \log_6 7 \cdot \log_7 8 \cdot \log_8 9 = x$, then the value of x is

(a) 4 (b) 2 (c) 3 (d) 1

ANSWER KEY

1. (c) 2. (c) 3. (b) 4. (a) 5. (b) 6. (b) 7. (a) 8. (a) 9. (b) 10. (d)
11. (b) 12. (c) 13. (d) 14. (c) 15. (b)





Equations

Cheat Sheet by Anurag Sir

EQUATIONS

Any mathematical statement which states that left hand side is equals to Right hand side.

$$\text{LHS} = \text{RHS}$$

E.g., $2x + 3 = 5x^2 - 7x$

E.g., $3x^2 - 8x + 9 = 0$

E.g., $x^2 + y^2 = 16$

Degree of Equation

Highest power of variable is known as Degree of equation.

E.g., $4x^2 + 5x + 3 = 0$

Degree = 2

E.g., $2x^3 + 8x + 9 = 0$

Degree = 3

E.g., $5x + 7y + 6 = 0$

Degree = 1

Types of Equation on the Basis of Degree

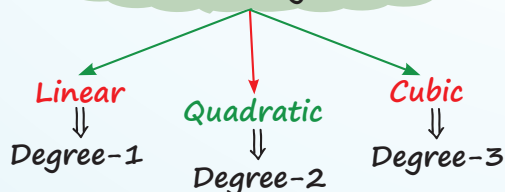

Solution of the Equation

The value of variable which satisfy the equation is known as Root of equation or solution of the equation.

E.g., $3x + 7 = 5x + 3$

$x = 2$ is a solution of this equation because if we put $x = 2$, LHS & RHS will become equal.

LHS = $3(2) + 7$	RHS = $5(2) + 3$
= 13	= 13

LHS = RHS

Linear Equation

in one variable

$$ax + b = 0$$

in two variable

$$ax + by + c = 0$$

Methods of Solving Linear Equation in two Variables

Substitution Method

Elimination Method

Substitution Method

- Two equations will be given
- Find the value of x in terms of y in both equation
- Equate two equation

E.g. $x + 3y = 7$

$$2x + y = 4$$

Find x & y

Sol. $x + 3y = 7$ & $2x + y = 4$

$$\Downarrow$$

 $x = 7 - 3y$

$$\Downarrow$$

 $2x = 4 - y$

$$x = \frac{4 - y}{2}$$

Equate

$$7 - 3y = \frac{4 - y}{2}$$

$$2(7 - 3y) = 4 - y$$

$$14 - 6y = 4 - y$$

$$14 - 4 = -y + 6y$$

$$10 = 5y$$

$$y = 2$$

$$\begin{aligned} \text{Now, } x &= 7 - 3y \\ x &= 7 - 3(2) \\ x &= 1 \end{aligned}$$

Elimination Method

- Two Equations are given
- Select one variable & make its coefficient same in both Equation
- Then eliminate that variable using addition or subtraction

E.g. $2x + 3y = 5$

$$\begin{aligned} 5x + 2y &= 7 \\ \text{Find } x \text{ \& } y \end{aligned}$$

Sol. In given two equation, eliminate variable 'y'

$$[2x + 3y = 5] \times 2$$

$$[5x + 2y = 7] \times 3$$

$$\begin{bmatrix} 4x + 6y = 10 \\ 15x + 6y = 21 \end{bmatrix}$$

Subtract second from first

$$\begin{aligned} 4x + 6y &= 10 \\ -15x - 6y &= -21 \\ \hline -11x &= 11 \end{aligned}$$

$$x = 1$$

Now, $4x + 6y = 10$

$$\begin{aligned} 4(1) + 6y &= 10 \\ 6y &= 10 - 4 \\ 6y &= 6 \\ y &= 1 \end{aligned}$$

QUADRATIC EQUATION

$ax^2 + bx + c = 0$ where $a \neq 0$. It can have maximum two roots which are generally denoted by ' α ' & ' β '.

$$\text{Sum of two Roots} = \alpha + \beta = \frac{-b}{a}$$

$$\text{Product of Two Roots} = \alpha \cdot \beta = \frac{c}{a}$$

$$\alpha^2 + \beta^2 = (\alpha + \beta)^2 - 2\alpha\beta$$

$$\alpha^3 + \beta^3 = (\alpha + \beta)(\alpha^2 + \beta^2 - \alpha\beta)$$

$$(\alpha + \beta)^2 - (\alpha - \beta)^2 = 4\alpha\beta$$

- When one Root is the reciprocal of other Root Then, $a = c$
- When sign of two roots is opposite but magnitude is same then, $b = 0$
- If one Irrational Root is $m + \sqrt{n}$. Then other irrational root will be $m - \sqrt{n}$.
- If sum of roots & Product of roots is given. Then Quadratic Equation,

$$x^2 - (\text{sum of roots})x + \text{Product} = 0$$

E.g. Find Q.E. whose Roots are 3 & 8

Sol. Sum of roots = $3 + 8 = 11$

Product of Roots = $3 \times 8 = 24$

Q.E. will be

$$x^2 - 11x + 24 = 0$$

Methods of Solving Quadratic Equation

Factorisation Method

Quadratic Method

- Factorisation method: (middle term splitting)
- Calculate $a \times c$
- Find two factor of ac such that their sum of Difference is equal to b .

E.g. $2x^2 + 11x + 14 = 0$

Find x

Sol. $a = 2, b = 11, c = 14$

$$ac = 2 \times 14 = 28$$

1×28	2×14	4×7
$1+28=29$	$2+14=16$	$4+7=11$
$1-28=-27$	$2-14=-12$	\checkmark
x	x	

So, $2x^2 + 11x + 14 = 0$

$$2x^2 + 7x + 4x + 14 = 0$$

$$x(2x + 7) + 2(2x + 7) = 0$$

$$(x + 2)(2x + 7) = 0$$

Now, $x + 2 = 0$

$$x = -2$$

And, $2x + 7 = 0$

$$x = \frac{-7}{2}$$

Quadratic Formula

→ Find a, b & c

→ Apply formula

$$x = \frac{-b \pm \sqrt{b^2 - 4ac}}{2a}$$

E.g. $2x^2 + 11x + 14 = 0$

$a = 2, b = 11, c = 14$

$$x = \frac{-11 \pm \sqrt{(11)^2 - 4(2)(14)}}{2(2)}$$

$$x = \frac{-11 \pm \sqrt{9}}{4} \Rightarrow x = \frac{-11 \pm 3}{4}$$

Now, $x = \frac{-11 + 3}{4} \Rightarrow x = \frac{-8}{4}$

$x = -2$

And, $x = \frac{-11 - 3}{4}$

$$x = \frac{-14}{4} \Rightarrow x = \frac{-7}{2}$$

DISCRIMINANT = D

$$D = b^2 - 4ac$$

□ It will tell nature of roots

□ If $D = b^2 - 4ac > 0$

Roots are real and Different

□ If $D = b^2 - 4ac = 0$

Roots are Real and Equal

□ If $D = b^2 - 4ac < 0$

Roots are not real

□ If D is positive perfect square then root can be rational

□ If D is not perfect square then roots can be irrational

CUBIC EQUATION

$$ax^3 + bx^2 + cx + d = 0$$

[Where $a \neq 0$]

It can have maximum 3 roots α, β & γ

$$\alpha + \beta + \gamma = \frac{-b}{a}$$

$$\alpha\beta + \beta\gamma + \alpha\gamma = \frac{c}{a}$$

$$\alpha\beta\gamma = \frac{-d}{a}$$

Cubic Equation

$$x^3 - (\alpha + \beta + \gamma)x^2 + (\alpha\beta + \beta\gamma + \alpha\gamma)x - \alpha\beta\gamma = 0$$

QUESTIONS

Linear Equation

1. The solution of the linear simultaneous equations $2x - y = 4$ and $3x + 4y = 17$ is [PYQ-Dec., 2023]

- (a) $x = 3; y = 2$
- (b) $x = 2; y = 3$
- (c) $x = -3; y = -2$
- (d) $x = -2; y = -3$

2. The solution of the following system of linear equation $2x - 5y + 4 = 0$ and $2x + y - 8 = 0$ will be [PYQ-Dec., 2022]

- (a) (2, -3)
- (b) (1, -3)
- (c) (3, 2)
- (d) (-2, 2)

3. The point of intersection between the straight lines $3x + 2y = 6$ and $3x - y = 12$ lie in

[MTP-May, 2025]

- (a) 1st quadrant
- (b) 2nd quadrant
- (c) 3rd quadrant
- (d) 4th quadrant

4. The age of a man is four times the sum of the ages of his two sons and after 10 years, his age will be double the sum of their ages. The present age of the man is [PYQ-June, 2023]

- (a) 56 years
- (b) 45 years
- (c) 60 years
- (d) 64 years

5. The value of y of fraction $\frac{x}{y}$ exceeds with x by 5 and if 3 be added to both numerator and denominator of the fraction it becomes $\frac{3}{4}$. Find the fraction. **[MTP-June, 2023]**

- (a) $\frac{12}{17}$ (b) $\frac{13}{17}$
 (c) $-\frac{1}{3}$ (d) None of these

6. A man wants to cut three lengths from a single piece of board of length 91 cm. The second length is to be 3 cm longer than the shortest and third length is to be twice as the shortest. What is the possible length for the shortest piece? **[PYQ-June, 2022]**

- (a) 22 cm (b) 20 cm
 (c) 15 cm (d) 18 cm

7. What are the values of x and y from the given equation?

$$\frac{x}{2} - \frac{y}{5} = y - x \text{ and } \frac{x-5}{y-10} = 1 \quad \text{[PYQ-Jan., 2025]}$$

- (a) (20, 25) (b) (15, 20)
 (c) (25, 30) (d) (30, 35)

8. The cost prices of 3 pens and 4 bags is ₹324 and 4 pens and 3 bags is ₹257, then cost price of 1 bag is equal to **[PYQ-Dec., 2022]**

- (a) ₹8 (b) ₹24
 (c) ₹32 (d) ₹75

9. 4 tables and 3 chairs together cost ₹2,250 and 3 table and 4 chairs cost ₹1950. Find the cost of 2 chairs and 1 table. **[MTP-June, 2024]**

- (a) ₹550 (b) ₹1005
 (c) ₹750 (d) None of these

10. A fraction becomes 1 when 3 is added to the numerator and 1 is added to the denominator. But when the numerator and denominator are decreased by 2 and 1 respectively, it becomes $\frac{1}{2}$. The denominator of the fraction is **[PYQ-June 2024]**

- (a) 8 (b) 6
 (c) 7 (d) 5

11. A man starts his job with a certain monthly salary and earns a fixed increment every year. If his salary was ₹1500 after 4 years of service and ₹1800 after 100 years of service, what was his starting salary and what is the annual increment in rupees? **[MTP-Dec., 2023]**

- (a) ₹1300, ₹50 (b) ₹1100, ₹50
 (c) ₹1500, ₹30 (d) None

Quadratic Equation

12. The roots of the equation $x^2 - 7x + 10 = 0$ are **[PYQ-June, 2024]**

- (a) 2 and 5 (b) -2 and -5
 (c) 2 and -5 (d) -2 and 5

13. If the square of a number exceeds twice of the number by 15, then number that satisfies the condition is **[PYQ-Dec., 2021]**

- (a) -5 (b) 3
 (c) 5 (d) 15

14. If α and β are the roots of the equation $x^2 - 8x + 12 = 0$, then $\frac{1}{\alpha} + \frac{1}{\beta} = ?$ **[0]**

- (a) $\frac{2}{3}$ (b) $\frac{3}{4}$
 (c) $\frac{4}{5}$ (d) $\frac{5}{6}$

15. If one root of $5z^2 + 13z + y = 0$ is reciprocal of the other, then the value of y is **[PYQ-June, 2022]**

- (a) $\frac{1}{5}$ (b) $-\frac{1}{5}$
 (c) 5 (d) -5

16. One root of the equation $x^2 - 2(5+m)x + 3(7+m) = 0$ is reciprocal of the other. Find the value of m . **[MTP-June 2024]**

- (a) $-\frac{20}{3}$ (b) 7
 (c) $\frac{1}{7}$ (d) 117

17. If α, β are the roots of the equation $x^2 - 4x + 1 = 0$, then the value of $\alpha^3 + \beta^3$ will be **[PYQ-June 2022]**

- (a) -76 (b) 76
 (c) -52 (d) 52

18. The quadratic equation $2x^2 - \sqrt{5}x + 1 = 0$ has
[PYQ-May, 2025]

- (a) two distinct real roots
(b) two equal real roots
(c) no real roots
(d) more than two real roots

19. If one root of the equation $x^2 - 3x + k = 0$ is 1, then the value of 'k' is
[PYQ-Sept., 2024]

- (a) 2 (b) 1
(c) -2 (d) -1

20. Find the condition that one root is double that of other equation $ax^2 + bx + c = 0$
[PYQ-June, 2019]

- (a) $2b^2 = 3ac$ (b) $b^2 = 3ac$
(c) $2b^2 = 9ac$ (d) None

21. The equation $x^2 - (p + 4)x + 2p + 5 = 0$, has equal roots, the value of p will be

- (a) 2 (b) -2
(c) ± 2 (d) 3

22. What will be the value of k, if the roots of the equation $(k - 4)x^2 - 2kx + (k + 5) = 0$ are equal?
[PYQ-Dec., 2022]

- (a) 18 (b) 20
(c) 19 (d) 21

23. When two roots of quadratic equation are $\alpha, \frac{1}{\alpha}$, then what will be quadratic equation?
[PYQ-Nov., 2018]

- (a) $\alpha x^2 - (\alpha^2 + 1)x + \alpha = 0$
(b) $\alpha x^2 - \alpha^2 x + 1 = 0$
(c) $\alpha x^2 - (\alpha^2 + 1)x + 1 = 0$
(d) None of these

24. If difference between a number and its positive square root is 12, the numbers are
[MTP-June, 2023]

- (a) 9 (b) 16
(c) 25 (d) None of these

25. If α and β are the roots of the equation $ax^2 + bx + c = 0$, then the equation whose roots are $\frac{1}{\alpha}$ & $\frac{1}{\beta}$ is
[PYQ-June, 2024]

- (a) $cx^2 - bx + a = 0$ (b) $cx^2 + bx + a = 0$
(c) $x^2 + bx + a = 0$ (d) $x^2 + bx - a = 0$

26. If arithmetic mean between roots of a quadratic equation is 8 and the geometric mean between them is 5, the equation is: [MTP-Dec., 2023]

- (a) $x^2 - 16x - 25 = 0$ (b) $x^2 - 16x + 25 = 0$
(c) $x^2 - 16x + 5 = 0$ (d) None of these

27. If α and β are the roots of the quadratic equation $x^2 - 2x - 3 = 0$, then the equation whose roots are $\alpha + \beta$ and $\alpha - \beta$ is; [PYQ-June, 2023]

- (a) $x^2 - 6x - 8 = 0$ (b) $x^2 - 6x + 8 = 0$
(c) $x^2 + 6x + 8 = 0$ (d) $x^2 + 6x - 8 = 0$

28. If α, β are the roots of the quadratic equation $3x^2 - 4x + 1 = 0$; the equation having roots $\frac{\alpha^2}{\beta}, \frac{\beta^2}{\alpha}$ is
[MTP-Sept., 2024]

- (a) $9x^2 - 28x + 3 = 0$ (b) $9x^2 - 28x + 1 = 0$
(c) $9x^2 - 28x + 5 = 0$ (d) None of these

Cubic Equation

29. The roots of the cubic equation $x^3 - 7x + 6 = 0$ are; [MTP-Dec., 2023]

- (a) 1, 2 and 3 (b) 1, -2 and 3
(c) 1, 2 and -3 (d) 1, -2 and -3

30. The equation $x^3 - 3x^2 - 4x + 12 = 0$ has three real roots. They are [PYQ-June, 2024]

- (a) -2, 2, 3 (b) -2, -2, 3
(c) -2, 2, -3 (d) -2, -2, -3

31. The three roots of equation $x^3 + 9x^2 - x - 9 = 0$ is [PYQ-Dec., 2019]

- (a) 1, -1, -9 (b) 1, -1, 9
(c) 1, 1, 9 (d) -1, -1, -9

32. The value of 'k' is _____, if 2 is a root of the following cubic equation; $x^3 - (k + 1)x + k = 0$
[PYQ-July, 2021]

- (a) 2 (b) 6
(c) 1 (d) 4

33. If one of the root of the cubic equation $3x^3 - 5x^2 - 11x - 3 = 0$ is $-\frac{1}{3}$, then other two roots are; [PYQ-Sept., 2024]

- (a) 1 and 3 (b) -1 and 3
(c) 1 and -3 (d) -1 and -3

34. For equation $x^3 - 6x^2 + 5x + 12 = 0$, the product of two roots is 12. Which of the following is correct set of roots of the equation? [PYQ-May, 2025]

- (a) 1, -3, -4 (b) 1, 6, 2
(c) -1, 3, 4 (d) -1, -6, -2

ANSWER KEY

- | | | | | | | | | | |
|---------|---------|---------|---------|---------|---------|---------|---------|---------|---------|
| 1. (a) | 2. (c) | 3. (d) | 4. (c) | 5. (a) | 6. (a) | 7. (a) | 8. (d) | 9. (c) | 10. (c) |
| 11. (a) | 12. (a) | 13. (c) | 14. (a) | 15. (c) | 16. (a) | 17. (d) | 18. (c) | 19. (a) | 20. (c) |
| 21. (c) | 22. (b) | 23. (a) | 24. (b) | 25. (b) | 26. (b) | 27. (b) | 28. (a) | 29. (c) | 30. (a) |
| 31. (a) | 32. (b) | 33. (b) | 34. (c) | | | | | | |

HINTS & SOLUTIONS

1. (a) Given, equation; $2x - y = 4$ and $3x + 4y = 17$

Multiplying first equation by 4 and adding to second equation, we get

$$8x - 4y = 16$$

$$3x + 4y = 17$$

$$\hline 11x = 33$$

$$\Rightarrow x = 3$$

Therefore, $y = 2x - 4 = 6 - 4 = 2$

2. (c) Given Equation,

$$2x - 5y + 4 = 0 \quad \dots\dots(i)$$

$$2x + y - 8 = 0 \quad \dots\dots(ii)$$

Subtracting both equations, we get

$$-5y - y + 4 + 8 = 0$$

$$\Rightarrow 6y = 12$$

$$\Rightarrow y = 2$$

Substitute the value of x in eq (i), we get

$$2x - 10 + 4 = 0$$

$$\Rightarrow 2x = 6$$

$$\Rightarrow x = 3$$

Therefore, $(x, y) = (3, 2)$

3. (d) Given lines; $3x + 2y = 6$ (i)

$$3x - y = 12 \quad \dots\dots(ii)$$

Multiplying eq (i) by 2, we get,

$$6x - 2y = 24 \quad \dots\dots(iii)$$

Now adding eq (i) and eq (iii), we get

$$3x + 2y = 6$$

$$6x - 2y = 24$$

$$\hline 9x = 30$$

$$\Rightarrow x = \frac{10}{3}$$

Substitute the value of x in eq., (ii) we get

$$\Rightarrow 3 \times \frac{10}{3} - y = 12$$

$$\Rightarrow y = -2$$

Therefore, $(x, y) = \left(\frac{10}{3}, -2\right)$

Hence, the solution set lies in 4th quadrant.

4. (c) Let the present age of the man be ' x ' years and that of his sons be ' y ' years, then

According to question, we have

$$x = 4y \quad \dots\dots(i)$$

Also, $x + 10 = 2(y + 20)$

$$\Rightarrow x + 10 = 2y + 40$$

$$\Rightarrow x + 10 = \frac{x}{2} + 40$$

$$\Rightarrow x - \frac{x}{2} = 40 - 10$$

$$\Rightarrow \frac{x}{2} = 30$$

$$\Rightarrow x = 60$$

Therefore, the present age of man is 60 years.

5. (a) According to the question, we have

$$y - x = 5 \quad \dots\dots(i)$$

$$\frac{x+3}{y+3} = \frac{3}{4}$$

$$\Rightarrow 4(x+3) = 3(y+3)$$

$$\Rightarrow 4x + 12 = 3y + 9$$

$$\Rightarrow 4x - 3y = -3 \quad \dots\dots(ii)$$

Multiplying eq., (i) with 4 and adding with eq., (ii), we get

$$4y - 4x = 20$$

$$4x - 3y = -3$$

$$\underline{4y - 3y = 17}$$

$$\Rightarrow y = 17$$

$$\text{Thus, } y = 17 - 5 = 12$$

Therefore, the fraction is $\frac{12}{17}$.

6. (a) Let the shortest piece be x cm.

According to the question,

Second length = ' $x + 3$ ' cm and

Third length = ' $2x$ ' cm

$$\text{Thus, } x + x + 3 + 2x = 91$$

$$\Rightarrow 4x = 91 - 3$$

$$\Rightarrow 4x = 88$$

$$\Rightarrow x = 22$$

Therefore, the length of shortest piece of board is 22 cm.

7. (a) Given Equations;

$$\frac{x}{2} - \frac{y}{5} = y - x \text{ and } \frac{x-5}{y-10} = 1$$

$$\Rightarrow \frac{5x - 2y}{10} = y - x$$

$$\Rightarrow 5x - 2y = 10y - 10x$$

$$\Rightarrow 15x = 12y$$

$$\Rightarrow 5x = 4y$$

.....(i)

$$\text{Also, } \frac{x-5}{y-10} = 1$$

$$\Rightarrow x - 5 = y - 10$$

$$\Rightarrow x - y = -5$$

$$\Rightarrow \frac{4y}{5} - y = -5 \text{ (From i)}$$

$$\Rightarrow \frac{-y}{5} = -5$$

$$\Rightarrow y = 25$$

$$\Rightarrow x = \frac{4y}{5} = 20$$

Therefore, the required solution is (20, 25)

8. (d) Let the cost price of 1 pen be ₹ x and of bag be ₹ y .

According to the question,

$$3x + 4y = 324 \text{ \& } 4x + 3y = 257$$

On adding the equations, we get

$$7x + 7y = 581$$

$$\Rightarrow x + y = 83 \quad \text{.....(i)}$$

On subtracting, we get

$$-x + y = 67 \quad \text{.....(ii)}$$

From (i) and (ii), we have

$$2y = 150$$

$$\Rightarrow y = 75$$

Therefore, the price of 1 bag is ₹75.

9. (c) Let the cost of each table and chair be ₹ x and ₹ y respectively.

According to question, we have

$$4x + 3y = 2250 \quad \text{....(i)}$$

$$3x + 4y = 1950 \quad \text{....(ii)}$$

Multiplying eq.(i) by 3 and eq.(ii) by 4 and subtracting them, we get

$$16x + 12y - (9x + 12y) = 9000 - 5850$$

$$\Rightarrow 7x = 3150$$

$$\Rightarrow x = 450$$

Therefore,

$$y = \frac{1950 - 3(450)}{4} = 150$$

Hence, the cost of 2 chairs and 1 table be $2y + x = 2(150) + 450 = ₹750$

10. (c) Let the numerator be x and the denominator by y , then

According to question,

$$\frac{x+3}{y+1} = 1$$

$$\Rightarrow x + 3 = y + 1$$

$$\Rightarrow x - y = -2 \quad \text{.....(i)}$$

$$\text{Also, } \frac{x-2}{y-1} = \frac{1}{2}$$

$$\Rightarrow 2(x - 2) = (y - 1)$$

$$\Rightarrow 2x - 4 = y - 1$$

$$\Rightarrow 2x - y = 3 \quad \text{.....(ii)}$$

From (i) and (ii), we get

$$2x - x = 3 + 2$$

$$\Rightarrow x = 5$$

Therefore, $y = x + 2 = 5 + 2 = 7$

11. (a) Let the starting salary be ₹ a and the annual increment be ₹ b .

As the salary was ₹1500 after 4 years of service, we get

$$\Rightarrow a + 4b = 1500 \quad \dots(i)$$

Similarly, as the salary was ₹1800 after 10 years of service, we get,

$$\Rightarrow a + 10b = 1800 \quad \dots(ii)$$

Now, on solving eq.,(i) and eq.,(ii) simultaneously, we get,

$$\Rightarrow 6b = 300$$

$$\Rightarrow b = 50$$

Substitute this value of b in eq., (i)

$$\Rightarrow a + 200 = 1500$$

$$\Rightarrow a = 1300$$

Thus, the starting salary is ₹1300 and the annual increment is ₹50.

12. (a) $x^2 - 7x + 10 = 0$

$$\Rightarrow x^2 - 2x - 5x + 10 = 0$$

$$\Rightarrow x(x - 2) - 5(x - 2) = 0$$

$$\Rightarrow (x - 2)(x - 5) = 0$$

$$\Rightarrow x = 2, 5$$

Therefore, the roots of the given equations are 2 and 5.

13. (c) Let the number be x , where $x > 0$ then

$$x^2 = 2x + 15$$

$$\Rightarrow x^2 - 2x - 15 = 0$$

$$\Rightarrow x^2 - 5x + 3x - 15 = 0$$

$$\Rightarrow x(x - 5) + 3(x - 5) = 0$$

$$\Rightarrow (x + 3)(x - 5) = 0$$

$$\Rightarrow x = -3, x = 5$$

Therefore, the value of x is 5.

14. (a) Given, α and β are the roots of $x^2 - 8x + 12 = 0$, thus

$$\alpha + \beta = -\frac{(-8)}{1} = 8$$

$$\alpha\beta = \frac{12}{1} = 12$$

Thus,

$$\frac{1}{\alpha} + \frac{1}{\beta}$$

$$= \frac{\alpha + \beta}{\alpha\beta} = \frac{8}{12} = \frac{2}{3}$$

15. (c) Given equation; $5z^2 + 13z + y = 0$

Let one root of the equation be α , then the other root will be $\frac{1}{\alpha}$.

Comparing the given equation with standard equation $az^2 + bz + c = 0$, we get

$$a = 5 \text{ and } b = 13 \text{ and } c = y$$

Now product of roots = $\frac{c}{a}$

$$\Rightarrow \alpha \cdot \frac{1}{\alpha} = \frac{y}{5}$$

$$\Rightarrow 1 = \frac{y}{5}$$

$$\Rightarrow y = 5$$

16. (a) Given equation; $x^2 - 2(5 + m)x + 3(7 + m) = 0$

Let the roots be α & $\frac{1}{\alpha}$.

We know that,

For quadratic equation $ax^2 + bx + c = 0$, its

product of roots = $\frac{c}{a}$

Therefore, for given quadratic equation

$$\text{Product of roots} = \alpha \cdot \frac{1}{\alpha} = \frac{3(7 + m)}{1}$$

$$\Rightarrow 3(7 + m) = 1$$

$$\Rightarrow m = -\frac{20}{3}$$

17. (d) Given equation; $x^2 - 4x + 1 = 0$

Comparing it with $ax^2 + bx + c = 0$, we get

$$a = 1, b = -4 \text{ \& } c = 1$$

$$\text{Thus, Sum of roots, } \alpha + \beta = -\frac{b}{a} = 4$$

$$\text{Product of roots, } \alpha\beta = \frac{c}{a} = 1$$

We know that,

$$(\alpha + \beta)^3 = \alpha^3 + \beta^3 + 3\alpha\beta(\alpha + \beta)$$

$$\Rightarrow \alpha^3 + \beta^3 = (\alpha + \beta)^3 - 3\alpha\beta(\alpha + \beta)$$

$$\Rightarrow \alpha^3 + \beta^3 = (4)^3 - 3(1)(4)$$

$$\Rightarrow \alpha^3 + \beta^3 = 64 - 12$$

$$\Rightarrow \alpha^3 + \beta^3 = 52$$

18. (c) Given equation, $2x^2 - \sqrt{5}x + 1 = 0$

Comparing with standard quadratic equation $ax^2 + bx + c = 0$, we get

$$a = 2, b = -\sqrt{5} \text{ \& } c = 1$$

Now, discriminant is given by;

$$b^2 - 4ac = (-\sqrt{5})^2 - 4(2)(1)$$

$$\Rightarrow b^2 - 4ac = 5 - 8$$

$$\Rightarrow b^2 - 4ac = -3 < 0$$

Therefore, the given quadratic equation has no real roots.

19. (a) Since, 1 is the root of the equation $x^2 - 3x + k = 0$, thus

$$(1)^2 - 3(1) + k = 0$$

$$\Rightarrow 1 - 3 + k = 0$$

$$\Rightarrow -2 + k = 0 \Rightarrow k = 2$$

20. (c) Let α, β be the roots of the given equation

It is given that one root is double then;

$$\Rightarrow \alpha = 2\beta$$

Now we know that the quadratic equation is

$$\Rightarrow x^2 - (\text{sum of roots})x + \text{products of roots} = 0$$

The quadratic equation is $ax^2 + bx + c = 0$

$$\text{Sum of roots } (\alpha + \beta) = 3\beta = \frac{-b}{a} \quad \dots(i)$$

$$\text{Product of roots } (\alpha\beta) = 2\beta^2 = \frac{c}{a} \quad \dots(ii)$$

Therefore, from the above two equations

$$\text{We get, } \left(\frac{b^2}{9a^2}\right) = \frac{c}{2a}$$

On cross multiplying, we get

$$\Rightarrow 2b^2 = 9ac$$

21. (c) Given; $x^2 - (p + 4)x + 2p + 5 = 0$

We know that,

If the quadratic equation $ax^2 - bx + c = 0$ has equal roots then

$$D = b^2 - 4ac = 0$$

On comparing, we get

$$a = 1, b = -(p + 4), c = 2p + 5$$

Since, the roots are equal

$$\Rightarrow [-(p + 4)]^2 - 4(1)(2p + 5) = 0$$

$$\Rightarrow (p + 4)^2 - 8p - 20 = 0$$

$$\Rightarrow p^2 + 16 + 8p - 8p - 20 = 0$$

$$\Rightarrow p^2 - 4 = 0$$

$$\Rightarrow p^2 = 4 \Rightarrow p = \pm 2$$

Thus, the values of p are ± 2

Hence, the correct option is (c).

22. (b) Given Equation; $(k - 4)x^2 - 2kx + (k + 5) = 0$

Comparing the equation with standard equation $ax^2 + bx + c = 0$, we get

$$a = (k - 4), b = -2k \text{ \& } c = (k + 5)$$

Since, the roots of the equation are equal thus

$$D = 0$$

$$\Rightarrow b^2 - 4ac = 0$$

$$\Rightarrow (-2k)^2 - 4(k - 4)(k + 5) = 0$$

$$\Rightarrow 4k^2 - 4(k^2 - 4k + 5k - 20) = 0$$

$$\Rightarrow 4k^2 - 4k^2 - 4k + 80 = 0$$

$$\Rightarrow -4k + 80 = 0$$

$$\Rightarrow k = 20$$

Therefore, the value of k is 20.

23. (a) Given root of quadratic equation; $\alpha, \frac{1}{\alpha}$

We know that,

Quadratic equation is given by

$$x^2 - (\text{Sum of roots})x + \text{Product of roots} = 0$$

$$\Rightarrow x^2 - \left(\alpha + \frac{1}{\alpha}\right)x + \alpha \cdot \frac{1}{\alpha} = 0$$

$$\Rightarrow x^2 - \frac{(\alpha^2 + 1)}{\alpha}x + 1 = 0$$

$$\Rightarrow \alpha x^2 - (\alpha^2 + 1)x + \alpha = 0$$

24. (b) Let the number be ' a^2 ' such that $a > 0$

Then, its square roots will be $\sqrt{a^2} = a$

According to question, we have

$$a^2 - a = 12$$

$$\Rightarrow a^2 - a - 12 = 0$$

$$\Rightarrow a^2 - 4a + 3a - 12 = 0$$

$$\Rightarrow a(a - 4) + 3(a - 4) = 0$$

$$\Rightarrow (a + 3)(a - 4) = 0$$

$$\Rightarrow a = -3, 4$$

Since, a cannot be negative.

Hence, the value of $a^2 = 4^2 = 16$

25. (b) Given equation; $ax^2 + bx + c = 0$

Therefore, Sum of roots $= \alpha + \beta = -\frac{b}{a}$

Product of roots $= \alpha\beta = \frac{c}{a}$

Now, the equations whose roots are $\frac{1}{\alpha}$ & $\frac{1}{\beta}$ is given by;

$$x^2 - \left(\frac{1}{\alpha} + \frac{1}{\beta}\right)x + \frac{1}{\alpha\beta} = 0$$

$$\Rightarrow x^2 - \left(\frac{\alpha + \beta}{\alpha\beta}\right)x + \frac{1}{\alpha\beta} = 0$$

$$\Rightarrow x^2 - \left(\frac{-\frac{b}{c}}{\frac{a}{c}}\right)x + \frac{a}{c} = 0$$

$$\Rightarrow x^2 + \frac{b}{c}x + \frac{a}{c} = 0$$

$$\Rightarrow cx^2 + bx + a = 0$$

Therefore, the required equation is $cx^2 + bx + a = 0$

Trick:

If α and β are the roots of the equation $ax^2 + bx + c = 0$, then $\frac{1}{\alpha}$ and $\frac{1}{\beta}$ are the roots of the equation $cx^2 + bx + a = 0$

26. (b) Let the two roots be α and β

$$\Rightarrow \frac{\alpha + \beta}{2} = 8 \text{ (AM of } a \text{ and } b \text{ is } \frac{a+b}{2}) \quad \dots(i)$$

$$\text{and } \sqrt{ab} = 5 \text{ (GM of } a \text{ and } b \text{ is } \sqrt{ab}) \quad \dots(ii)$$

From eq., (i)

$$\Rightarrow \alpha + \beta = 16$$

$$\text{Sum of roots} = \alpha + 16$$

From eq., (ii)

$$\Rightarrow \sqrt{ab} = 5$$

$$\Rightarrow \alpha\beta = 25$$

Products of roots = 25

Now, we know that if we have the sum of roots and product of roots then the quadratic equation is given by

$$x^2 - (\text{sum of the roots})x + \text{product of the roots} = 0$$

$$\Rightarrow x^2 - 16x + 25 = 0$$

27. (b) Given, $x^2 - 2x - 3 = 0$

Since, α and β are the roots of $x^2 - 2x - 3 = 0$, then

$$\alpha + \beta = \frac{(-2)}{1} = 2$$

$$\alpha\beta = \frac{-3}{1} = -3$$

$$\text{Now, } (\alpha - \beta)(\alpha + \beta) = 2 \times 4 = 8$$

$$\text{Also, } (\alpha - \beta)^2 = (\alpha + \beta)^2 - 4\alpha\beta$$

$$\Rightarrow (\alpha - \beta)^2 = (2)^2 - 4(-3)$$

$$\Rightarrow (\alpha - \beta)^2 = 4 + 12$$

$$\Rightarrow (\alpha - \beta)^2 = 16$$

$$\Rightarrow (\alpha - \beta) = 4$$

Therefore, the equation will be:

$$x^2 - (\text{Sum of roots})x + \text{Product of roots} = 0$$

$$\Rightarrow x^2 - [(\alpha + \beta) + (\alpha - \beta)]x + (\alpha + \beta)(\alpha - \beta) = 0$$

$$\Rightarrow x^2 - (2 + 4)x + 2 \times 4 = 0$$

$$\Rightarrow x^2 - 6x + 8 = 0$$

28. (a) Given quadratic equation; $3x^2 - 4x + 1 = 0$

$$\Rightarrow \alpha + \beta = \frac{-(-4)}{3} = \frac{4}{3} \Rightarrow \alpha\beta = \frac{1}{3}$$

Therefore, the quadratic equation with roots $\frac{\alpha^2}{\beta}, \frac{\beta^2}{\alpha}$ is given by

$$x^2 - \left(\frac{\alpha^2}{\beta} + \frac{\beta^2}{\alpha}\right)x + \frac{\alpha^2}{\beta} \times \frac{\beta}{\alpha} = 0$$

$$\Rightarrow x^2 - \frac{\alpha^3 + \beta^3}{\alpha\beta} \cdot x + \alpha\beta = 0 \quad \dots(i)$$

We know, $\alpha^3 + \beta^3 = (\alpha + \beta)^3 - 3\alpha\beta(\alpha + \beta)$

$$\Rightarrow \alpha^3 + \beta^3 = \left(\frac{4}{3}\right)^3 - 3 \cdot \frac{1}{3} \left(\frac{4}{3}\right)$$

$$\Rightarrow \alpha^3 + \beta^3 = \frac{64}{27} - \frac{4}{3} = \frac{28}{27}$$

Substituting the values in eq(i), we get

$$x^2 - \frac{\frac{28}{27}}{\frac{1}{3}}x + \frac{1}{3} = 0$$

$$\Rightarrow x^2 - \frac{28}{9}x + \frac{1}{3} = 0$$

$$\Rightarrow 9x^2 - 28x + 3 = 0$$

29. (c) Given equation; $x^3 - 7x + 6 = 0$

Comparing the given equation with general equation $ax^3 + bx^2 + cx + d = 0$, we get

$$a = 1, b = 0, c = -7 \text{ and } d = 6$$

We know,

$$\text{Sum of roots} = -\frac{b}{a} = 0$$

GBC:

For option (a):

$$\text{Sum of roots} = 1 + 2 + 3 \neq 0$$

For option (b):

$$\text{Sum of roots} = 1 + (-2) + 3 \neq 0$$

For option (c):

$$\text{Sum of roots} = 1 + 2 + (-3) = 0 \text{ which is true.}$$

Hence, the roots of the equation are 1, 2 and -3.

30. (a) Given Equation; $x^3 - 3x^2 - 4x + 12 = 0$
 $\Rightarrow x^3 - 3x^2 - 4x + 12 = 0$
 $\Rightarrow x^2(x - 3) - 4(x - 3) = 0$
 $\Rightarrow (x - 3)(x^2 - 4) = 0$
 $\Rightarrow (x - 3)(x - 2)(x + 2) = 0$
 $\Rightarrow x = 3, x = 2, x = -2$

Go by options:

Thus, Sum of roots = $-\frac{b}{a} = -\frac{(-3)}{1} = 3$

For option (a); -2, 2, 3

Sum of roots = $-2 + 2 + 3 = 3$

For option (b); -2, -2, 3

Sum of roots = $-2 - 2 + 3 = -1$

For option (c); -2, 2, -3

Sum of roots = $-2 + 2 - 3 = -3$

For option (d); -2, -2, -3

Sum of roots = $-2 - 2 - 3 = -7$

Clearly, the roots of the given equation is -2, 2 and 3.

31. (a) Given; $x^3 + 9x^2 - x - 9 = 0$
 $\Rightarrow x^2(x + 9) - 1(x + 9) = 0$
 $\Rightarrow (x^2 - 1)(x + 9) = 0$
 $\Rightarrow (x + 1)(x - 1)(x + 9) = 0$
 $\Rightarrow (x + 1) = 0, (x - 1) = 0, (x + 9) = 0$
 $\Rightarrow x = 1, -1, -9 \Rightarrow x = \pm 1, -9$
Hence, the correct option is (a).

32. (b) Given cubic equation; $x^3 - (k + 1)x + k = 0$
Since, 2 is a root of the equation, thus it will satisfy the given equation.
 $\Rightarrow (2)^3 - (k + 1)(2) + k = 0$
 $\Rightarrow 8 - (2k + 2) + k = 0$
 $\Rightarrow 8 - 2k - 2 + k = 0$
 $\Rightarrow 6 - k = 0 \Rightarrow k = 6$
Hence, the correct option is (b) i.e., 6

33. (b) Given equation; $3x^3 - 5x^2 - 11x - 3 = 0$
Let α, β and γ be the roots of the given cubic equation such that $\gamma = -\frac{1}{3}$
We know,
Sum of roots = $\alpha + \beta + \gamma = -\frac{(-5)}{3} = \frac{5}{3}$
 $\Rightarrow \alpha + \beta - \frac{1}{3} = \frac{5}{3}$
 $\Rightarrow \alpha + \beta = 2$ (i)

Product of roots = $\alpha\beta\gamma = -\frac{(-3)}{3} = 1$

$\Rightarrow \alpha\beta\left(-\frac{1}{3}\right) = 1$

$\Rightarrow \alpha\beta = -3$ (ii)

From (i) and (ii), we get

$\alpha - \frac{3}{\alpha} = 2$

$\Rightarrow \alpha^2 - 2\alpha - 3 = 0$

$\Rightarrow \alpha^2 + \alpha - 3\alpha - 3 = 0$

$\Rightarrow \alpha(\alpha + 1) - 3(\alpha + 1) = 0$

$\Rightarrow (\alpha - 3)(\alpha + 1) = 0$

$\Rightarrow \alpha = -1, \alpha = 3 \Rightarrow \beta = 3, -1$

Therefore, the other two roots are -1 and 3.

34. (c) Given: $x^3 - 6x^2 + 5x + 12 = 0$

Let the roots be a, b and c

According to the question, the product of two roots is 12 i.e., $ab = 12$

Also, product of all the roots is -12.

So, $abc = -12$

$12c = -12 \Rightarrow c = -1$

Now, the sum of roots is 6, thus

$a + b + c = 6$

$a + b = 7$

Since, $ab = 12$

$a = \frac{12}{b}$

On putting the value of a , we get

$\frac{12}{b} + b = 7$

$\Rightarrow \frac{12 + b^2}{b} = 7$

$\Rightarrow 12 + b^2 = 7b$

$\Rightarrow b^2 - 7b + 12 = 0$

$\Rightarrow b^2 - 3b - 4b + 12 = 0$

$\Rightarrow (b - 3)(b - 4) = 0$

Either $(b - 3) = 0, (b - 4) = 0$

$\Rightarrow b = 3, b = 4$

Thus, $a = \frac{12}{b}$ i.e., $a = 3, 4$

Therefore, the roots are -1, 3, 4.

Chapter Wrap-up Test

Ready to test your knowledge?

You've got 15 questions and 20 minutes - go for it!

1. The solution of the following system of linear equation $2x - 5y + 4 = 0$ and $2x + y - 8 = 0$ will be
 - (a) (2, -3)
 - (b) (1, -4)
 - (c) (3, 2)
 - (d) (-2, 2)
2. The value of k so that $x = 1$ is the root of equation $x^3 + kx^2 - x - 9 = 0$ is
 - (a) 1
 - (b) 6
 - (c) -9
 - (d) 9
3. The positive root/roots of the equation $2x^2 - x = 6$ is given by
 - (a) 2
 - (b) 2 and $\frac{3}{2}$
 - (c) $\frac{3}{2}$
 - (d) 2 and $\frac{1}{2}$
4. One root of the equation; $x^2 - 2(5 + m)x + 3(7 + m) = 0$ is reciprocal of the other. Find the value of m .
 - (a) $-\frac{20}{3}$
 - (b) 7
 - (c) $\frac{1}{7}$
 - (d) $\frac{1}{17}$
5. If a number of which the half is greater than $\frac{1}{5}$ th the number by 15, then the number is
 - (a) 50
 - (b) 40
 - (c) 80
 - (d) None of these
6. The roots of the equation $y^3 + y^2 - y - 1 = 0$ are
 - (a) 1, 1, -1
 - (b) -1, -1, 1
 - (c) 1, 1, 1
 - (d) None
7. When two roots of quadratic equation are $\alpha, \frac{1}{\alpha}$, then what will be the quadratic equation?
 - (a) $\alpha x^2 - (\alpha^2 + 1)x + \alpha = 0$
 - (b) $\alpha x^2 - \alpha^2 x + 1 = 0$
 - (c) $\alpha x^2 - (\alpha^2 + 1)x + 1 = 0$
 - (d) None of these
8. If $2^{x+y} = 2^{2x-y} = \sqrt{8}$ then the respective values of x and y are
 - (a) 1, $\frac{1}{2}$
 - (b) $\frac{1}{2}, 1$
 - (c) $\frac{1}{2}, \frac{1}{2}$
 - (d) None of these
9. Product of the digits of a two-digit number is 20. If we add 9 to the number, the digits get reversed. Then the original two-digit number is
 - (a) 54
 - (b) 45
 - (c) 20
 - (d) 63
10. If the ratio of the roots of the equation $4x^2 - 6x + p = 0$ is 1 : 2, then the value of p is
 - (a) 1
 - (b) 2
 - (c) -2
 - (d) -1
11. If the roots of $(k - 4)x^2 - 2kx + (k + 5) = 0$ are coincident, then the value of k is
 - (a) 14
 - (b) 20
 - (c) 18
 - (d) 22
12. A man wants to cut three lengths from a single piece of board of length 91 cm. The second length is to be 3 cm longer than the shortest and third length is to be twice as the shortest. What is the possible length for the shortest piece?
 - (a) 22 cm
 - (b) 20 cm
 - (c) 15 cm
 - (d) 18 cm

13. If the roots of the quadratic equation;

$2x^2 + 5x - 3 = 0$ are α and β , what is the value of $|\alpha - \beta|$?

(a) $\frac{3}{2}$

(b) $\frac{2}{3}$

(c) $\frac{7}{2}$

(d) $\frac{5}{2}$

14. If $\frac{3}{x+y} + \frac{2}{x-y} = -1$; $\frac{1}{x+y} + \frac{1}{x-y} = \frac{4}{3}$; then (x, y) is

(a) 2, 1

(b) 1, 2

(c) -1, 2

(d) -2, 1

15. If α, β be the roots of $x^2 + x + 5 = 0$ then

$\frac{\alpha^2}{\beta} + \frac{\beta^2}{\alpha} =$

(a) $\frac{16}{5}$

(b) 2

(c) 3

(d) $\frac{14}{5}$

ANSWER KEY

1. (c) 2. (d) 3. (a) 4. (a) 5. (a) 6. (b) 7. (a) 8. (a) 9. (b) 10. (b)
11. (b) 12. (a) 13. (c) 14. (b) 15. (d)



3

Linear Inequalities

Cheat Sheet by Anurag Sir

If the equality symbol '=' in a linear equation is replaced by an inequality symbol (<, >, ≤ or ≥), then the statement is called linear inequality.

E.g.: $x \leq 3$, $x + y > 7$ etc.

1. Addition/Subtraction: The sign of inequality doesn't change on adding or subtracting the same quantity to both sides.

2. Multiplication/Division: The sign of inequality doesn't change while multiplying and dividing with positive integers on both sides. However, the sign changes when both sides gets multiply or divide by a negative integer.

LINEAR INEQUATION IN ONE VARIABLE

As the heading says, when there is an inequality on one variable then it will be called as linear inequation in one variable.

E.g.: $x \geq 5$, $y < 3$

Intervals (Solution Space) of an inequality

If $a < b$ and $a < x < b$ means that $a < x$ and $x < b$. That is, x is between a and b .

The following table will be make you understand it properly:

Interval	Inequality
$[a, b]$	$a \leq x \leq b$
$[a, b)$	$a \leq x < b$
$(a, b]$	$a < x \leq b$
(a, b)	$a < x < b$

Linear Inequation in Two Variables

Again as the heading says, when there is an inequality in two variables then it will be called as linear inequation in two variables. For example: $ax + by \leq c$, $x + 2y < 6$, $x + y \geq 5$, $3x + y > 9$ are some examples of the linear inequality of two variables.

E.g.: Let's plot a graph of $x + 2y \leq 10$

The line of equation corresponding to above inequality is $x + 2y = 10$

When $x = 0$ then $y = 5$

When $y = 0$ then $x = 10$

Thus, the points are $(0, 5)$ and $(10, 0)$

Now, put $x = 0$ and $y = 0$ in given inequality, we get

$$0 + 0 \leq 10$$

$0 \leq 10$, which is true

Thus, the shaded region will be towards the origin

Therefore, the required graph is:

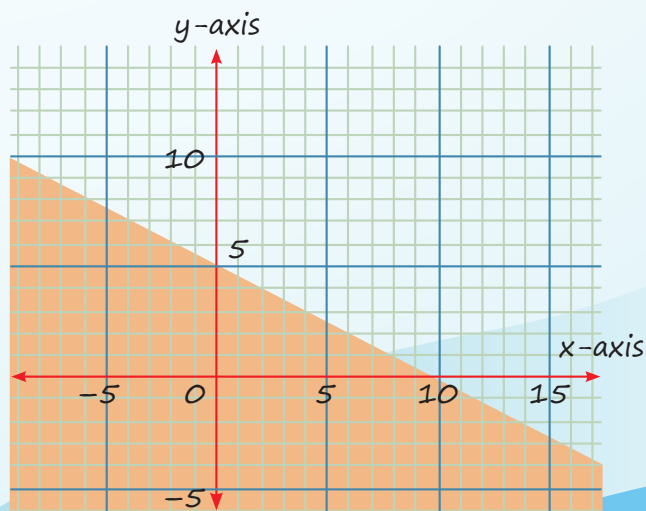

QUESTIONS

Linear Inequation in one variable

1. The solution set of the equations $x + 2 > 0$ and $2x - 6 > 0$ is [PYQ-June, 2019]

(a) $(-2, \infty)$ (b) $(3, \infty)$
 (c) $(-\infty, -2)$ (d) $(-\infty, -3)$

2. If $3x + 2 < 2x + 5$ and $4x - 5 \geq 2x - 3$, then x can take from the following values:

[PYQ-Dec., 2022, MTP-June, 2023]

(a) 3 (b) -1
 (c) 2 (d) -3

3. Solve for x of the inequalities

$$2 \leq \frac{3x-2}{5} \leq 4, \text{ where } x \in \mathbb{N} \quad \text{[MTP-Dec., 2023]}$$

(a) $\{5, 6, 7\}$ (b) $\{3, 4, 5, 6\}$
 (c) $\{4, 5, 6\}$ (d) $\{4, 5, 6, 7\}$

4. In a hostel, ration is stocked for 400 students for 31 days. After 28 days, 280 students vacate the hostel. Find the number of days for which the remaining ration will be sufficient for the remaining students

[PYQ-Dec., 2022, MTP-June, 2023]

(a) 5 (b) 4
 (c) 7 (d) 10

Linear Inequation in Two Variables

5. A senior typist can type five reports and a junior typist can type three reports per day. But the management needs to complete at least 30 reports in a day. If S and J denote the number of senior and junior typists assigned for the work, which of the following inequality represents the constraint? [PYQ-May 2025, PYQ-June 2024]

(a) $5S + 3J \leq 30$ (b) $3S + 5J < 30$
 (c) $5S + 3J \geq 30$ (d) $3S + 5J > 30$

6. A dealer has only ₹5760 to invest in fans (x) and sewing machines (y). The cost per unit of fan and sewing machine is ₹360 and ₹240 respectively. This can be shown by: [MTP-May, 2025]

(a) $360x + 240y \geq 5760$ (b) $360x + 240y \leq 5760$
 (c) $60x + 240y = 5760$ (d) None of these

7. A manufacturer produces two products A and B. The profit on product A is ₹8 on each unit, and the profit on product B is ₹13 on each unit. Then the objective function is: [PYQ-Jan., 2025]

(a) Maximize $Z = 8x_1 + 13x_2$
 (b) Minimize $Z = 8x_1 + 13x_2$
 (c) Minimize $Z = 13x_1 + 8x_2$
 (d) Maximize $Z = 13x_1 + 8x_2$

8. A manufacturer produces two items A and B. He has ₹10,000 to invest and space to store 100 items. A table costs him ₹400 and a chair ₹100. Express this in the form of linear inequalities.

[MTP-June, 2024]

(a) $x + y \leq 100, 4x + y \leq 100, x \geq 0, y \geq 0$
 (b) $x + y \leq 100, 2x + 5y < 1000, x \geq 0, y \geq 0$
 (c) $x + y > 100, 4x + y \geq 100, x \geq 0, y \geq 0$
 (d) None of these

9. On an average, an experienced person does 5 units of work whereas an unexperienced person does 3 units of work daily. The employer has to maintain output of at least 30 units of work per day. The situation can be expressed as: [MTP-Dec., 2023]

(a) $5x + 3y \leq 30$ (b) $5x + 3y \geq 30$
 (c) $5x + 3y = 30$ (d) None of these

10. A company produce two type of product A and B which required processing in two machines. First machine can be used up to 15 hrs. and second can be used at most 12 hrs. in a day. The product A requires 2 hrs. on machine 1 and 3 hrs. on machine 2. The product B requires 3 hrs. on machine 1 and 1 hour on machine 2. This can be expressed as: [PYQ-Jan 2025, MTP-May 2025]

(a) $2x_1 + 3x_2 \leq 15, 3x_1 + x_2 \leq 15$
 (b) $2x_1 + 3x_2 \leq 15, 3x_1 + x_2 \leq 12$
 (c) $3x_1 + 2x_2 \leq 15, 2x_1 + x_2 \leq 12$
 (d) $2x_1 + 3x_2 \leq 12, 3x_1 + x_2 \leq 15$

11. A dietician recommends mixture of two kinds of foods to a person so that mixture contains at least 45 units of carbs, 25 units of protein, 15 units of fat and 15 units of fibre. The above contents of nutrients are available in the foods as below:

	Carbs	Protein	Fat	Fibre
Food-1	20	5	3	2
Food-2	10	2	4	5

If ' x ' units of food-1 is mixed with ' y ' units of food-2, how dietician recommendation can be expressed? [PYQ-Sept., 2024]

- (a) $20x + 10y \leq 45$; $5x + 2y \geq 25$; $3x + 4y \leq 15$; $2x + 5y \geq 15$; $x \geq 0$; $y \geq 0$
- (b) $20x + 10y \leq 25$; $5x + 2y \geq 45$; $3x + 4y \leq 15$; $2x + 5y \geq 15$; $x \geq 0$; $y \geq 0$
- (c) $20x + 10y \geq 45$; $5x + 2y \geq 25$; $3x + 4y \geq 15$; $2x + 5y \geq 15$; $x \geq 0$; $y \geq 0$
- (d) $20x + 10y \leq 45$; $5x + 2y \leq 25$; $3x + 4y \leq 15$; $2x + 5y \leq 15$; $x \geq 0$; $y \geq 0$

12. A small manufacturing firm produces two types of gadgets A and B, which are first processed in the foundry then sent to the machine shop for finishing. The number of man-hours of labour required in each shop for the production of each unit of A and B, and the number of man-hours the firm has available per week are as follows:

Gadget	Foundry	Machine-Shop
A	10	5
B	6	4
Firm's capacity per week	1000	600

Let the firm manufactures x units of A and y units of B. The constraint are: **[MTP-June, 2024]**

- (a) $10x + 6y \leq 1000$, $5x + 4y \geq 600$, $x \geq 0$, $y \leq 0$
- (b) $10x + 6y \leq 1000$, $5x + 4y \leq 600$, $x \geq 0$, $y \geq 0$
- (c) $10x + 6y \geq 1000$, $5x + 4y \leq 600$, $x \leq 0$, $y \leq 0$
- (d) $10x + 6y \leq 1000$, $5x + 4y \geq 600$, $x \leq 0$, $y \leq 0$
13. Given the constraints $x \leq 3$, $y \leq 4$ and $4x + 3y \leq 12$, the point _____ is in the feasible region **[PYQ-May, 2025, PYQ-June, 2024]**

- (a) (3, 4) (b) (2, 4)
- (c) (2, 2) (d) (1, 1)

14. The shaded area is represented by which of the following option? **[PYQ-Sept., 2024]**

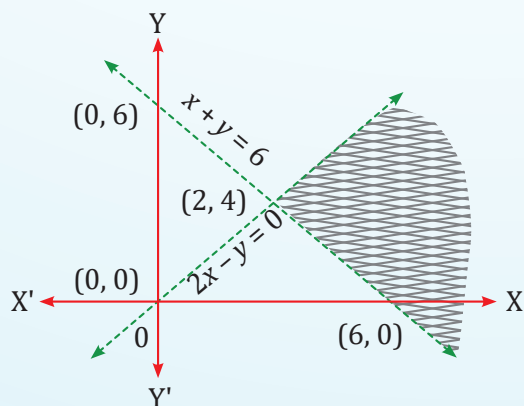

- (a) $x + y > 6$; $2x - y > 0$; $x > 0$
- (b) $x + y < 6$; $2x - y > 0$; $x < 0$
- (c) $x + y > 6$; $2x - y < 0$; $x > 0$
- (d) $x + y > 6$; $2x - y > 0$; $x < 0$

15. On solving the inequalities $5x + y \leq 100$, $x + y \leq 60$, $x \geq 0$, $y \geq 0$, we get the following situation

[PYQ, Nov., 2018]

- (a) (0, 0), (20, 0), (10, 50) and (0, 60)
- (b) (0, 0), (60, 0), (10, 50) and (0, 60)
- (c) (0, 0), (20, 0), (0, 100) and (10, 50)
- (d) None of these

16. On solving the inequalities $6x + y \geq 18$; $x + 4y \geq 12$; $2x + y \geq 10$, we get the following situation:

[MTP-June, 2023]

- (a) (0, 18), (12, 0), (4, 2) and (2, 6)
- (b) (3, 0), (0, 3), (4, 2) and (7, 6)
- (c) (5, 0), (0, 10), (4, 2) and (7, 6)
- (d) (0, 18), (12, 0), (4, 2), (0, 0) and (7, 6)

17. A firm makes two types of products: Type A and Type B. The profit on product A is ₹20 each and that on product B is ₹30 each. Both types are processed on three machines M1, M2 and M3. The time required in hours by each product and total time available in hours per week on each machine are as follows:

Machine	Product		Available Time
	A	B	
M1	3	3	36
M2	5	2	50
M3	2	6	60

The constraints can be formulated taking $x_1 =$ number of units A and $x_2 =$ number of unit of B as **[MTP-June, 2023]**

- (a) $x_1 + x_2 \leq 22$, $5x_1 + 2x_2 \leq 50$, $2x_1 + 6x_2 \leq 60$, $x_1 \geq 0$, $x_2 \geq 0$
- (b) $3x_1 + 3x_2 \geq 36$, $5x_1 + 2x_2 \leq 50$, $2x_1 + 6x_2 \geq 60$, $x_1 \geq 0$, $x_2 \geq 0$
- (c) $3x_1 + 3x_2 \leq 36$, $5x_1 + 2x_2 \leq 50$, $2x_1 + 6x_2 \leq 60$, $x_1 \geq 0$, $x_2 \geq 0$
- (d) None of these

ANSWER KEY

1. (b) 2. (c) 3. (d) 4. (c) 5. (c) 6. (b) 7. (a) 8. (a) 9. (b) 10. (b)
 11. (c) 12. (b) 13. (d) 14. (a) 15. (a) 16. (c) 17. (c)

HINTS & SOLUTIONS

1. (b) Since, $x + 2 > 0$

$$\Rightarrow x > -2$$

Also, $2x - 6 > 0$

$$\Rightarrow 2x > 6$$

$$\Rightarrow x > 3$$

From (i) and (ii), the common solution set will be:

$$x > 3$$

i.e., $(3, \infty)$

2. (c) $3x + 2 < 2x + 5$

$$\Rightarrow 3x - 2x < 5 - 2$$

$$\Rightarrow x < 3$$

And, $4x - 5 \geq 2x - 3$

$$\Rightarrow 4x - 2x \geq -3 + 5$$

$$\Rightarrow 2x - 2 \Rightarrow x \geq -1$$

Combined:

$$-1 \leq x < 3$$

From given options, x can take the value of 2.

Therefore, the required value is 2.

3. (d) $2 \leq \frac{3x-2}{5} \leq 4$

$$10 \leq 3x - 2 \leq 20$$

$$12 \leq 3x \leq 22$$

$$4 \leq x \leq \frac{22}{3} \Rightarrow 4 \leq x \leq 7.33$$

Since $x \in \mathbb{N}$, possible values of x are:

$$\{4, 5, 6, 7\}$$

4. (c) Total stock of ration = $400 \times 31 \times 1 = 12400$ units (assuming 1 unit per student per day).

Ration consumed in first 28 days by 400 students = $400 \times 28 \times 1 = 11200$

Remaining ration = $12400 - 11200 = 1200$

Remaining students = $400 - 280 = 120$

Let remaining ration last for D days:

$$120 \times D \times 1 = 1200$$

$$120D = 1200$$

$$\Rightarrow D = \frac{1200}{120} = 10$$

5. (c)

- Let S = number of senior typists
- Let J = number of junior typists
- A senior typist types 5 reports/day \rightarrow contributes $5S$
- A junior typist type 3 reports/day \rightarrow contributes $3J$

The company wants at least 30 reports done in a day, so the total contribution must be greater than or equal to 30:

$$5S + 3J \geq 30$$

6. (b) The total investment cannot exceed ₹5760.

- Cost per fan = ₹360
- Cost per sewing machine = ₹240

Let:

- x = number of fans
- y = number of sewing machines

Then the total cost is:

$$360x + 240y \leq 5760$$

7. (a) Let:

- x_1 = number of units of product A
- x_2 = number of units of product B

Since, we want to maximize profit, and profit per unit of A is ₹8 and B is ₹13:

Therefore, the objective function is;

$$\text{Maximize } Z = 8x_1 + 13x_2$$

8. (a) Let;

- x = number of tables (item A)
- y = number of chairs (item B)

According to question, we have

- Total budget = ₹10,000
- Cost of a table = ₹400 → total cost from tables = $400x$
- Cost of a chair = ₹100 → total cost from chairs = $100y$

Therefore,

$$400x + 100y \leq 10,000$$

$$4x + y \leq 100$$

Also given;

- Maximum storage = 100 items

$$\text{Thus, } x + y \leq 100$$

Now the number of tables and chairs cannot be negative, thus

$$x \geq 0, y \geq 0$$

$$\text{Hence, } x + y \leq 100, 4x + y \leq 100, x \geq 0, y \geq 0$$

9. (b) Let;

- x = number of experienced workers
- y = number of unexperienced workers

Work done by experienced: $5x$

Work done by unexperienced: $3y$

Total work: $5x + 3y$

Given: Employer needs at least 30 units of work per day, so;

$$5x + 3y \geq 30$$

10. (b) From the given data:

Machine 1:

- Product A takes 2 hours
- Product B takes 3 hours
- Total machine 1 time used:
$$2x_1 + 3x_2 \leq 15$$

Machine 2:

- Product A takes 3 hours
- Product B takes 1 hour
- Total machine 2 time used:
$$3x_1 + x_2 \leq 12$$

So, the correct constraints are:

$$2x_1 + 3x_2 \leq 15, 3x_1 + x_2 \leq 12$$

11. (c) Let;

- x = units of Food-1
- y = units of Food-2

Now calculate the total nutrients from the mixture:

- **Carbohydrates:** $20x + 10y \geq 45$
- **Protein:** $5x + 2y \geq 25$
- **Fat:** $3x + 4y \geq 15$
- **Fibre:** $2x + 5y \geq 15$

Also, $x \geq 0, y \geq 0$

So the correct inequalities are:

$$20x + 10y \geq 45$$

$$5x + 2y \geq 25$$

$$3x + 4y \geq 15$$

$$2x + 5y \geq 15$$

$$x \geq 0$$

$$y \geq 0$$

12. (b) **Foundry constraint**

- Each unit of A uses 10 hrs, B uses 6 hrs
- Total available in foundry = 100 hrs

$$10x + 6y \leq 1000$$

Machine-shop constraint

- Each unit of A uses 5 hrs, B uses 4 hrs
- Total available = 600 hrs

$$5x + 4y \leq 600$$

Non-negativity constraints

- Cannot produce negative units:

$$x \geq 0, y \geq 0$$

Therefore, the constraints are:

$$10x + 6y \leq 1000, 5x + 4y \leq 600, x \geq 0, y \geq 0$$

13. (d) Go by options

For option (a): (3, 4)

Here,

$$3 \leq 3, \text{ true}$$

$$4 \leq 4, \text{ true}$$

$$4(3) + 3(4) = 24 \leq 12$$

For option (b): (2, 4)

$$2 \leq 3, \text{ true}$$

$$4 \leq 4, \text{ true}$$

$$4(2) + 3(4) = 20 \leq 12$$

For option (c): (2, 2)

$$2 \leq 3, \text{ true}$$

$$4 \leq 4, \text{ true}$$

$$4(2) + 3(2) = 14 \leq 12$$

For option (d): (1, 1)

$$1 \leq 3, \text{ true}$$

$$1 \leq 4, \text{ true}$$

$$4(1) + 3(1) = 7 \leq 12, \text{ true}$$

14. (a) Let us consider a point in the shaded portion of the intersection of lines.

Taking the point (7, 1)

Now, let us substitute this point in all the inequalities for each option and check if it satisfies the inequalities.

For option (a),

$$\Rightarrow x + y > 6$$

$$\Rightarrow 7 + 1 = 8 > 6, \text{ which is true}$$

$$\Rightarrow 2x - y > 0$$

$$\Rightarrow 2(7) - 1 = 13 > 0, \text{ which is true}$$

All inequalities are satisfied.

For option (b),

$$\Rightarrow x + y < 6$$

$$\Rightarrow 7 + 1 = 8, \text{ which is not less than 6.}$$

Inequalities are not satisfied.

For option (c)

$$\Rightarrow x + y > 6$$

$$\Rightarrow 7 + 1 = 8 > 6, \text{ which is true}$$

$$\Rightarrow 2x - y < 0$$

$$\Rightarrow 2(7) - 1 = 13, \text{ which is not less than 0.}$$

Inequalities are not satisfied.

For option (d), as all the inequalities in option (a) are satisfied by the point (7, 1) in the shaded region, so the option (d) is incorrect.

Thus, the shaded region represents:

$$x + y > 6, 2x - y > 0$$

15. (a) The inequalities are:

$$5x + y \leq 100$$

$$x + y \leq 60$$

The line of equation for inequality: $5x + y \leq 100$

$$\Rightarrow 5x + y = 100$$

Reference of points:

x	0	20	10
y	100	0	50

The line of equation for inequality: $x + y \leq 60$

$$\Rightarrow x + y = 60$$

Reference of points:

x	0	60	10
y	60	0	50

For the inequalities, the value of x and y will lie either on the lines $x + y = 60$ and $5x + y = 100$ or below them.

It is given $x \geq 0, y \geq 0$

Thus the value of x and y belongs to 1st quadrant

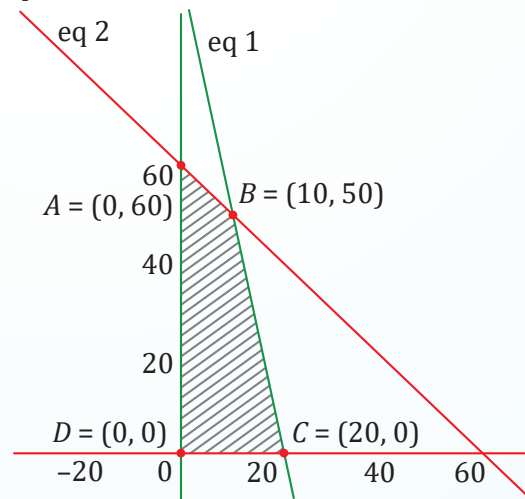

Thus we get the four points

$$A = (0, 60); B = (10, 50); C = (20, 0); D = (0, 0)$$

16. (c) Given inequalities;

1. $6x + y > 18$

2. $x + 4y > 12$

3. $2x + y > 10$

$6x + y = 18$ passes through points:

- When $x = 0, y = 18 \rightarrow (0, 18)$

- When $y = 0, x = 3 \rightarrow (3, 0)$

$x + 4y = 12$ passes through points:

- When $x = 0, y = 3 \rightarrow (0, 3)$

- When $y = 0, x = 12 \rightarrow (12, 0)$

$2x + y = 10$ passes through points:

- When $x = 0, y = 10 \rightarrow (0, 10)$

- When $y = 0, x = 5 \rightarrow (5, 0)$

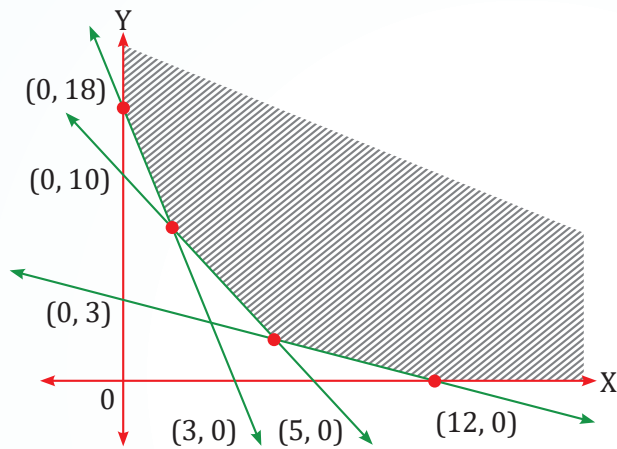

The shaded area on the graph shows the feasible region that satisfies all inequalities.

Therefore, the vertices of the feasible region are $(0, 18)$, $(12, 0)$, $(4, 2)$ & $(2, 6)$.

Trick: Go be choices

Option (a): $(0, 18)$, $(12, 0)$, $(4, 2)$ and $(2, 6)$

Check for all the given inequalities i.e.,

$$6x + y \geq 18; x + 4y \geq 12; 2x + y \geq 10$$

Clearly, all the points are satisfying the inequalities, whereas the points given in other options are not satisfying the inequalities.

For $(0, 18)$

$$6(0) + 18 \geq 18, \text{ true}$$

$$(0) + 4(18) \geq 12, \text{ true}$$

$$2(0) + 18 \geq 10, \text{ true}$$

For $(12, 0)$

$$6(12) + 0 \geq 18, \text{ true}$$

$$12 + 4(0) \geq 12, \text{ true}$$

$$2(12) + 0 \geq 10, \text{ true}$$

For $(4, 2)$

$$6(4) + 2 \geq 18, \text{ true}$$

$$4 + 4(2) \geq 12, \text{ true}$$

$$2(4) + 2 \geq 10, \text{ true}$$

For $(2, 6)$

$$6(2) + 6 \geq 18, \text{ true}$$

$$2 + 4(6) \geq 12, \text{ true}$$

$$2(2) + 6 \geq 10, \text{ true}$$

Clearly, all the points are satisfying the inequalities, whereas the points given in other options are not satisfying the inequalities.

17. (c) Given: x_1 = number of units of A and x_2 = number of units of B

Clearly, $x_1 \geq 0, x_2 \geq 0$

According to the given data,

The constraints can be formulated as:

$$3x_1 + 3x_2 \leq 36$$

$$5x_1 + 2x_2 \leq 50$$

$$2x_1 + 6x_2 \leq 60 \text{ such that } x_1 \geq 0, x_2 \geq 0$$



Chapter Wrap-up Test

Ready to test your knowledge?

You've got 15 questions and 20 minutes - go for it!

1. $-6x < -18$ implies

- (a) $x < 3$ (b) $x > 3$
 (c) $x = 0$ (d) $x = 3$

2. An employer recruits experienced (x) and fresh workmen (y) for his under the condition that he can not employ more than 11 people and y can be related by the inequality.

- (a) $x + y \neq 11$
 (b) $x + y \leq 11, x \geq 0, y \geq 0$
 (c) $x + y \geq 11, x \geq 0, y \geq 0$
 (d) None of these

3. If $3x + 2 < 2x + 5$ and $4x - 5 \geq 2x - 3$, then x can take from the following values

- (a) 3 (b) -1
 (c) 2 (d) -3

4. The inequalities $x_1 \geq 0, x_2 \geq 0$, are represented by one of the graphs shown below:

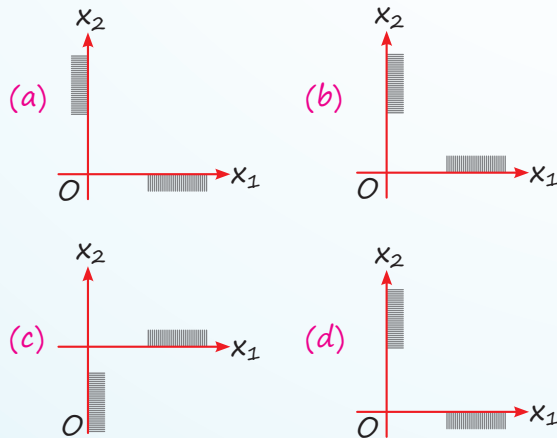

5. The solution of the inequality $\frac{5-2x}{3} \leq \frac{x}{6} - 5$ is

- (a) $x \leq 8$ (b) $x \geq 8$
 (c) $x = 8$ (d) None of these

6. The time required to produce a unit of product A is 3 hours and that for product B is 5 hours. The total available time is 220 hours. If x and y are the number of units of A and B that are produced then,

- (a) $3x + 2y = 220$
 (b) $3x + 2y \geq 220, x \geq 0, y \geq 0$
 (c) $3x + 5y \leq 220, x \geq 0, y \geq 0$
 (d) $5x + 2y \geq 220, x \geq 0, y \geq 0$

7. In the inequality $4x + 3 < 2x + 5$, all of the following can be a value of x except

- (a) 0 (b) 1
 (c) -1 (d) -2

8. On the average an experienced person does 5 units of work while a fresh one 3 units of work daily but the employer has to maintain an output of at least units of work per day. This situation can be expressed as:

- (a) $5x + 3y \leq 30$
 (b) $5x + 3y > 30$
 (c) $5x + 3y \geq 30, x \geq 0, y \geq 0$
 (d) None of these

9. Solve for real 'x' if

$$5x - 2 \geq 2x + 1 \text{ and } 2x + 3 < 18 - 3x$$

- (a) $-1 > x > -3$
 (b) $-1 > x > -5$
 (c) $1 \leq x < 3$
 (d) $x = 3$

10. The solution of the inequality

$$8x + 6 < 12x + 14 \text{ is}$$

- (a) $(-2, 2)$ (b) $(-2, 0)$
 (c) $(2, \infty)$ (d) $(-2, \infty)$

11. The common region of $x + y \leq 6, x + y \geq 3$ is shown by the shaded region:

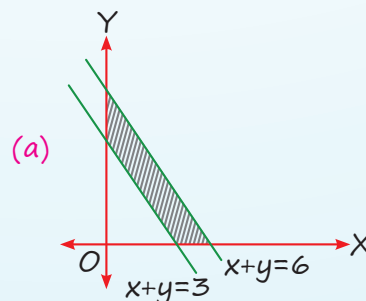

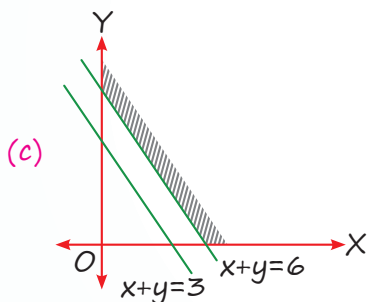
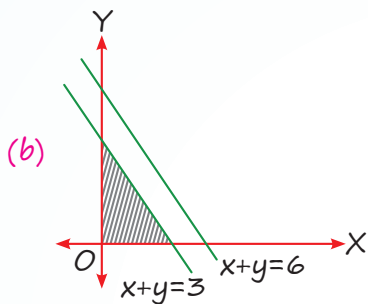

(d) None of these

12. A dietitian wishes to mix together two kinds of food so that the vitamin content of the mixture is at least 9 units of vitamin A, 7 units of vitamin B, 10 units of vitamin C and 12 units of vitamin D. The vitamin content per kg of each food is shown below:

	A	B	C	D
Food-I	2	1	1	3
Food-II	1	1	2	3

Assuming x units of food I is to be mixed with y units of food II, the situation can be expressed as

- (a) $2x + y \leq 9, x + y \leq 7, x + 2y \leq 10, 2x + 3y \leq 12, x > 0, y > 0$
- (b) $2x + y \geq 30, x + y \leq 7, x + 2y \geq 10, x + 3y \geq 12$
- (c) $2x + y \geq 9, x + y \geq 7, x + y \leq 10, x + 3y \geq 12$
- (d) $2x + y \geq 9, x + y \geq 7, x + 2y \geq 10, 2x + 3y \geq 12, x \geq 0, y \geq 0$

13. The shaded region represents:

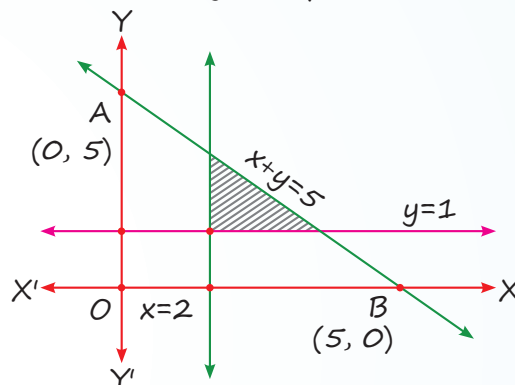

- (a) $x + y \leq 5, x \geq 2, y \leq 1$
- (b) $x + y \leq 5, x \geq 2, y \geq 1$
- (c) $x + y \geq 5, x \geq 2, y \geq 1$
- (d) None of these

14. On solving the inequalities

$5x + y \leq 100, x + y \leq 60, x \geq 0, y \geq 0$, we get the following situation:

- (a) $(0, 0), (20, 0), (10, 50)$ and $(0, 60)$
- (b) $(0, 0), (60, 0), (10, 50)$ and $(0, 60)$
- (c) $(0, 0), (20, 0), (0, 100)$ and $(10, 50)$
- (d) None of these

15. The shaded region represents:

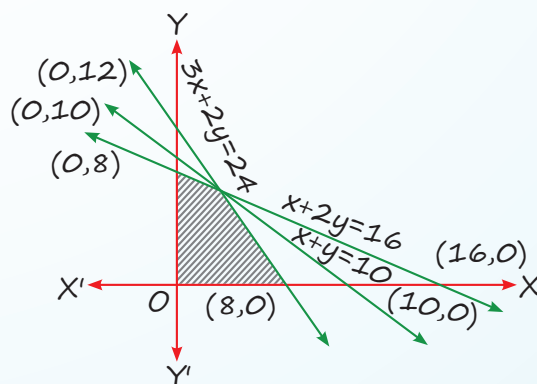

- (a) $3x + 2y \leq 24, x + 2y \geq 16, x + y \leq 10, x \geq 0, y \geq 0$
- (b) $3x + 2y \leq 24, x + 2y \leq 16, x + y \geq 10, x \geq 0, y \geq 0$
- (c) $3x + 2y \leq 24, x + 2y \leq 16, x + y \leq 10, x \geq 0, y \geq 0$
- (d) None of these

ANSWER KEY

1. (b) 2. (b) 3. (c) 4. (b) 5. (b) 6. (c) 7. (b) 8. (c) 9. (c) 10. (d)
11. (a) 12. (d) 13. (b) 14. (a) 15. (c)

37



Mathematics of Finance

Cheat Sheet by Anurag Sir

- ❑ **Finance:** Art & Science of Management and money.
- ❑ **Interest:** Cost of using others money.

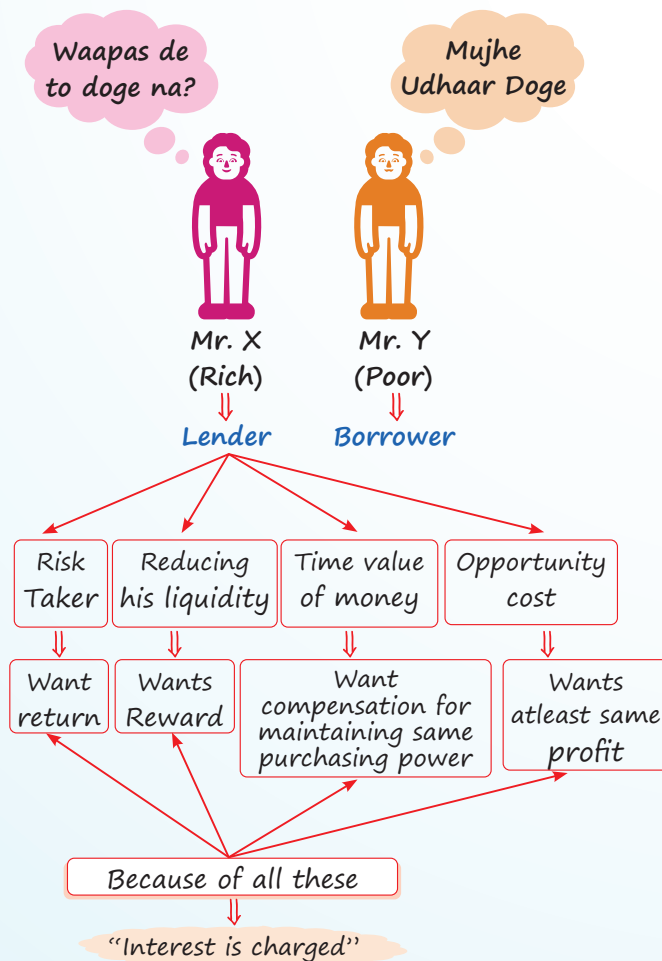

Some Important terms

- ❑ **Principal:** Borrowed Money (Invested Money)
- ❑ **Amount or (Accumulated Amount)** = (Principal + Interest)

Types of Interest

Simple Interest

Compound Interest

SIMPLE INTEREST

No Interest on Interest

- ❑ $S.I = P \cdot r \cdot t$
 $P =$ Principal
 $r =$ Rate of Interest in Decimal
 $t =$ Time
 Now, Amount = $P + I = P + Prt$
- ❑ Amount = $P[1 + rt]$

In Simple Interest

For Double Amount $r = \frac{1}{t}$ & $t = \frac{1}{r}$

For Triple Amount

$$r = \frac{2}{t} \text{ \& } t = \frac{2}{r}$$

In Simple Interest when two time & amount are given

$$\begin{matrix} t_1 & t_2 \\ A_1 & A_2 \end{matrix}$$

$$\text{Then, } r = \frac{A_2 - A_1}{A_1 t_2 - A_2 t_1}$$

In Simple Interest when two rates & two amount are given

$$\begin{matrix} r_1 & r_2 \\ A_1 & A_2 \end{matrix}$$

$$\text{Then, } t = \frac{A_2 - A_1}{A_1 r_2 - A_2 r_1}$$

COMPOUND INTEREST

Interest on Interest is also calculated
In Compound Interest

$$\text{Amount} = P \left[1 + \frac{r}{m} \right]^{t \times m}$$

m = No. of Conversion Period in a year

For Annually $\Rightarrow m = 1$

For Semiannually $\Rightarrow m = 2$

For Quarterly $\Rightarrow m = 4$

For Monthly $\Rightarrow m = 12$

For Daily $\Rightarrow m = 365$

अगर Direct C.I Find करना हो तो

$$C.I = A - P = P \left[1 + \frac{r}{m} \right]^{t \times m} - P$$

$$C.I = P \left\{ \left(1 + \frac{r}{m} \right)^{t \times m} - 1 \right\}$$

Calculator Tricks

1. Square of Any number

$x^2 \Rightarrow$ Press \times एक बार
 \Rightarrow Press $=$ एक बार

2. Cube of Any number

$x^3 \Rightarrow$ Press \times एक बार
 \Rightarrow Press $=$ दो बार

3. For $(x)^n = ?$

\Rightarrow Press \times one time
 \Rightarrow Press $=$ $(n - 1)$ times

Example $(2)^{10}$

\Rightarrow \times one time
 \Rightarrow $=$ 9 times

4. Reciprocal of Any Number

$\left(\frac{1}{n} \right) \Rightarrow$ Press \div one time
 \Rightarrow Press $=$ one time

E.g., $\frac{1}{2} = 0.5$

\Rightarrow 2 on the screen

\Rightarrow Press \div

\Rightarrow Press $=$

5. $(x)^{\frac{1}{n}} = ?$

\rightarrow Press $\sqrt{\quad}$ 12 times

\rightarrow Subtract 1 Press $-$

\rightarrow Divide by n

\rightarrow Add 1 Press $+$

\rightarrow Press \times then $=$ \rightarrow 12 times

E.g., $(8)^{\frac{1}{3}}$

\rightarrow 8 on the screen

\rightarrow Press $\sqrt{\sqrt{\sqrt{\quad}}}$... 12 times

$\rightarrow -1$

$\rightarrow \div 3$

$\rightarrow +1$

$\rightarrow x =$

$x =$

$x =$

$x =$

12 times

E.g., $(2)^{4.5}$

\rightarrow 2 on the screen

\rightarrow Press $\sqrt{\sqrt{\sqrt{\quad}}}$... 12 times

$\rightarrow -1$

\rightarrow Multiply by 4.5

$\rightarrow +1$

$\rightarrow x =$

$x =$

$x =$

$x =$

12 times

6. $\log_{10}(x) = ?$

$\rightarrow \sqrt{\quad}$ 19 times

$\rightarrow -1$

\rightarrow Multiply by 227695

\downarrow

Remember Property of log

\downarrow

$\text{Log}(x)^n = n \log x$

E.g., $\log(1.5)^{10} = 10 \log(1.5)$

7. Anti $\log(x) = ?$

$\rightarrow \div 227695$

$\rightarrow +1$

\rightarrow $\times =$ 19 times

E.g. $P = 100$

$A = 200$

$r = 10\%$ Annually

Find Time

Sol. $A = P \left[1 + \frac{r}{m} \right]^{t \times m}$

$$200 = 100 \left[1 + \frac{0.10}{1} \right]^{t \times 1}$$

$$2 = (1.10)^t$$

Here power is variable so we have to use log.

Put log both side

$$\log 2 = \log(1.10)^t$$

$$\log 2 = t \log(1.10)$$

$$t = \frac{\log 2}{\log(1.10)}$$

Now use log Trick

$$t = \frac{0.3010}{0.0414}$$

$$t = 7.27 \text{ years}$$

E.g. $P = 100$

$$A = 300$$

$$t = 8 \text{ years}$$

Find compound rate of interest

Sol. $A = P \left[1 + \frac{r}{m} \right]^{t \times m}$

$$300 = 100[1 + r]^8$$

$$(3)^1 = (1 + r)^8$$

Here Base is variable, so transfer power 8 to left side

$$(3)^{1/8} = 1 + r$$

$$(3)^{1/8} - 1 = r$$

$$r = (3)^{1/8} - 1$$

→ $\sqrt[12]{}$ times

→ -1

→ ÷ 8

→ +1

→ $\times = 12$ times

Calculator Trick

$$r = 1.1472 - 1$$

$$r = 0.1472 \text{ or } 14.72\%$$

Depreciation

Decrease in value of Asset

C = Cost

d = Rate of Depreciation

t = Time period for which asset is used

S.V = Value of Asset after 't' years

$$\text{Scrap value (S.V)} = c[1 - d]^t$$

Nominal Rate

Any Rate which is compounded

→ Monthly

→ Quarterly

→ Semiannually

→ Daily

Isme Interest Kam dikhate,
But interest Jaada milta hai

Effective Rate

Any Annual compounding Rate

Isme Interest Jitna Dikhta hai,
utna hi milta hai.

Nominal Rate can be converted to effective

$$\text{rate } r_e = \left[1 + \frac{r}{m} \right]^m - 1$$

Example:

8% semiannually is nominal rate

It can be converted in annually

$$r_e = \left[1 + \frac{r}{m} \right]^m - 1$$

$$= \left[1 + \frac{0.08}{2} \right]^2 - 1$$

$$= (1.04)^2 - 1$$

$$= 1.0816 - 1$$

$$= 0.0816 \text{ or } 8.16\% \text{ (Effective Rate)}$$

8% Semiannually = 8.16% Annually (Both are Same)

Present value of an amount which is to be received in future.

$$\text{Present value} = \frac{\text{Future value}}{\left[1 + \frac{r}{m} \right]^{t \times m}}$$

E.g.

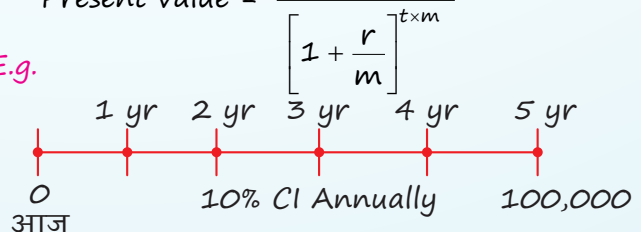

5 years ke baad ₹100,000 milenge, lekin wo paise agar aaj milenge to ₹100,000 nhi milega, thoda kam milega.

$$P.V. = \frac{100,000}{\left[1 + \frac{0.10}{1}\right]^5} = \frac{100,000}{1.61051}$$

P.V. = 62,092 (आज Bus इतना ही मिलेगा)

Annuity

- Sequence of payments (or Receipts)
- Same payment (5000, 5000, 5000, 5000)
- Same time interval between two payments (3m, 3m, 3m, 3m.....)

E.g. LIC Premium

→ House Loan EMI

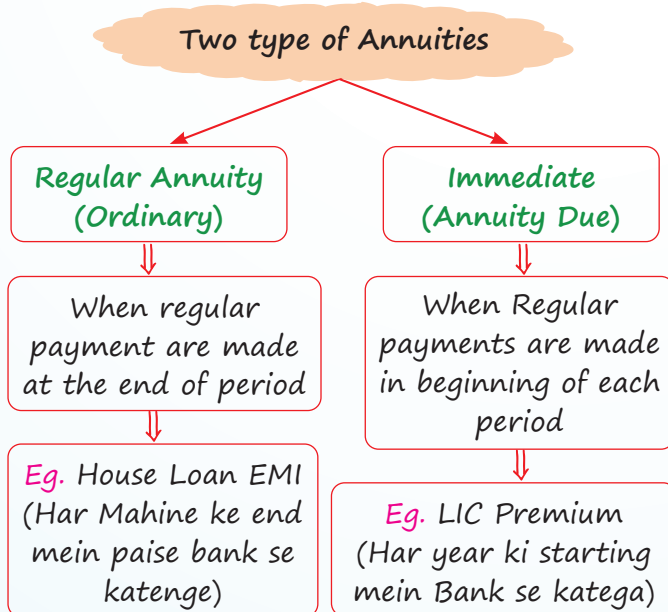

Regular Annuity

- **Future Value:** When benefit of many periodic investments is received in future.

$$F.V. = R \left[\frac{(1+i)^n - 1}{i} \right]$$

R = Regular Periodic Payment

$$i = \frac{r}{m}$$

n = t × m (Total Payments)

- **Present Value:** When some monetary benefit is received today then it is repaid in installment.

$$P.V. = R \left[\frac{1 - (1+i)^{-n}}{i} \right]$$

Immediate Annuity

$$F.V. = R \left[\frac{(1+i)^n - 1}{i} \right] (1+i)$$

$$P.V. = R \left[\frac{1 - (1+i)^{-n}}{i} \right] (1+i)$$

Perpetuity

Infinite Period Annuity

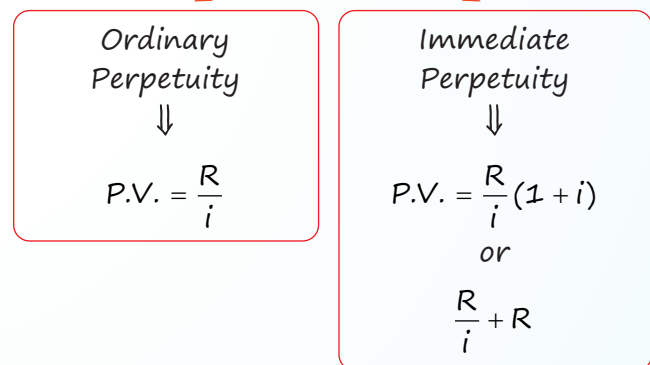

Growing Perpetuity

When regular payment is received with growth for infinite period

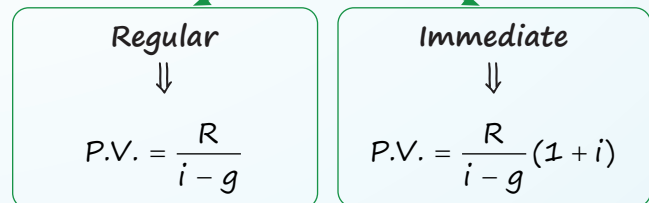

Sinking Fund

Saving money out of profit so that you can purchase an asset in future or you can payoff a liability in future.



Saved Amount is invested in when interest is earned.

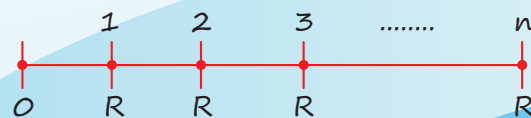

R = Saving

In this case benefit is received in future

F.V. of Regular Annuity will be used.

Net Present Value

Used for taking investment decision

NPV = Present value of all cash inflow - Present value of all cash outflow

If NPV > 0 Accept Proposal
If NPV < 0 Reject Proposal

Leasing

Taking Asset on Rent (For Long Period)

Owner of Asset

User of Asset

Lesser
मालिक

Lessee
किराएदार

In this type of question purchase value of Asset will be given.

But Problem is we don't know how much should be the Annual Rent?

Use P.V. of Regular Annuity to find Reasonable Rent

$$\text{Cost of Asset} = \text{Rent} \left[\frac{1 - (1+i)^{-n}}{i} \right]$$

Valuation of Bond

Price at which bond should be purchased

= Present value of all future interest

+ Present value of Bond's maturity value

Eg. Bond of ₹500 at which interest Rate is 10% and maturity period is 4 year. At what price it should be purchased if investor wants 15% Return.

Sol.

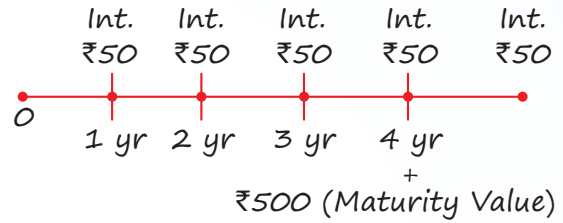

$$\begin{aligned} \text{Profit of Bond} &= \frac{50}{(1.15)^1} + \frac{50}{(1.15)^2} \\ &+ \frac{50}{(1.15)^3} + \frac{50}{(1.15)^4} + \frac{500}{(1.15)^4} \\ &= 43.47 + 37.80 + 32.87 + 28.58 + 285.87 \\ &= ₹428.59 \end{aligned}$$

C.A.G.R

Compound Annual Growth Rate

Eg.

Time	2010	2011	2012	2013
Revenue	100	110	140	160

Find CAGR

Sol. P = 100

A = 160

Time = 2013 - 2010 = 3 years

A = P[1 + r]^t

160 = 100[1 + r]³

$$\frac{160}{100} = (1+r)^3$$

$$\left(\frac{160}{100}\right)^{\frac{1}{3}} = 1+r$$

$$r = \left(\frac{160}{100}\right)^{\frac{1}{3}} - 1$$

or use Direct formula

$$\text{CAGR} = \left[\frac{v(tn)}{v(to)} \right]^{\frac{1}{tn-to}} - 1$$

$$= \left(\frac{160}{100}\right)^{\frac{1}{2013-2010}} - 1$$

$$= \left(\frac{160}{100}\right)^{\frac{1}{3}} - 1$$

$$= 1.1696 - 1$$

$$= 0.1696 \text{ or } 16.96\%$$

QUESTIONS

Simple Interest

1. In how many years will a sum of money becomes four times at 12% p.a. simple interest?

[MTP-June, 2022]

- (a) 18 years (b) 21 years
(c) 25 years (d) 28 years

2. Manoj invests ₹12,000 at 6% per annum simple interest to obtain a total amount of ₹14,880. What is the time for which the amount was invested

[PYQ-June, 2023]

- (a) 3 years (b) 4 years
(c) 2 years (d) 5 years

3. The simple interest if the principal is ₹2,000 and the rate and time are roots of the equation $x^2 - 11x + 30 = 0$ is

[MTP-June, 2022]

- (a) ₹500 (b) ₹600
(c) ₹700 (d) ₹800

4. The rate of interest for the first 2 year is 3% per annum, for next 3 years is 8% per annum and for the period beyond 5 years, 10% per annum. If a man gets ₹1520 as a simple interest for 6 years; how much money did he deposit?

[MTP-June, 2022]

- (a) ₹3800 (b) ₹3000
(c) ₹4000 (d) None of these

5. The annual rate of simple interest is 12.5%. In how many years does the Principal double?

[PYQ-Dec., 2022]

- (a) 11 years (b) 9 years
(c) 8 years (d) 7 years

Compound Interest

6. In what rate % per annum will ₹1,000 amounts to ₹1331 in 3 years if the interest is compounded yearly?

[MTP-June, 2022]

- (a) 10% (b) 12%
(c) 11% (d) None of these

7. The compound interest on ₹40,000 at 12% per annum compounded quarterly for 6 months is

[PYQ-Sept., 2024]

- (a) ₹2,643 (b) ₹2,463
(c) ₹2,364 (d) ₹2,436

8. The compound interest on ₹15,625 for 9 months at 16% per annum compounded quarterly is;

[PYQ-June, 2023]

- (a) ₹1851 (b) ₹1941
(c) ₹1951 (d) ₹1961

9. Kanta wants to accumulate Rs. 4,91,300 in her savings account after three years. The rate of interest offered by bank is $6\frac{1}{4}\%$ per annum compounded annually. How much amount should she invest today to achieve her target amount?

[PYQ-Sept., 2024]

- (a) Rs. 4,09,600 (b) Rs. 4,37,500
(c) Rs. 46,900 (d) Rs. 49,600

10. The present value of a scooter is ₹7290. The rate of depreciation is 10%. What was its value 3 years ago?

[MTP-June 2022]

- (a) ₹10,000 (b) ₹10,010
(c) ₹9990 (d) ₹12,000

11. The population of a town increases every year by 2% of the population at the beginning of that year. The approximate number of years by which the total increase of population will be 40% is _____. [Given: $(1.02)^8 = 1.17166$]

[PYQ-June, 2023]

- (a) 15 (b) 17
(c) 19 (d) 20

12. A machine depreciates at 10% of its value at the beginning of a year. The cost and scrap value realized at the time of sale being ₹23,240 and ₹9,000 respectively. Approximately, for how many years the machine is put to use?

[PYQ-June, 2023]

- (a) 7 years (b) 8 years
(c) 9 years (d) 10 years

13. The present population of town is 25,000. If it grows at the rate of 4%, 5% 8% during 1st year, 2nd year, 3rd year respectively, then find the population after 3 years.

[MTP-June, 2022]

- (a) 29,484 (b) 29,844
(c) 29,448 (d) 28,944

14. Compute the compound interest on ₹6,000 for $1\frac{1}{4}$ years at 8% p.a., interest will be compounded quarterly. [PYQ-Dec., 2023]

- (a) ₹642 (b) ₹630.78
(c) ₹634.68 (d) ₹624.48

15. What will be the population after 3 years, when present population is 1,00,000 and the population increases at 3% in 1st year, at 4% in second year and 5% in third year. [MTP-June, 2024]

- (a) 1,12,476 (b) 1,15,476
(c) 1,20,576 (d) 1,25,600

16. The difference between simple interest and compound interest on a certain for 2 years at 10% p.a., is ₹10. Find the sum. [MTP-June, 2022]

- (a) ₹1010 (b) ₹1095
(c) ₹1000 (d) ₹990

17. At a certain rate of interest per annum, the difference between the compound interest and simple interest on Rs. 3,00,000 for two years is Rs. 480, then the rate of interest per annum is; [PYQ-Sept., 2024]

- (a) 2% (b) 4%
(c) 6% (d) 8%

18. If the difference between the compound interest compounded annually and simple interest on a certain amount at 10% per annum for two years is ₹372, then the principal amount is [MTP-June, 2024]

- (a) ₹37,000 (b) ₹37,200
(c) ₹37,500 (d) None of these

19. There is 60% increase in an amount in 6 years at simple interest. What will be the compound interest of ₹12,000 after 3 years at the same rate? [PYQ-June, 2022]

- (a) ₹2,260 (b) ₹3,972
(c) ₹3,279 (d) ₹2,679

20. Mr. X makes a deposit of ₹50,000 in bank for a period of $2\frac{1}{2}$ years. If the rate of interest is 12% per annum compound half yearly, then the

maturity value of the money deposited by Mr. X is (where, $(1.06)^5 = 1.3382$) [PYQ-Dec., 2023]

- (a) ₹66910 (b) ₹66123
(c) ₹67925 (d) ₹66550

Effective Rate of Interest

21. The effective rate of interest does not depend upon [June 2022]

- (a) Amount of Principal
(b) Amount of Interest
(c) Number of Conversion periods
(d) None of these

22. Find the effective rate of interest at 10% p.a. when interest is payable quarterly. [MTP-June, 2022]

- (a) 10.38% (b) 5%
(c) 5.04% (d) 4%

23. The effective annual rate of interest corresponding to nominal rate 6% payable quarterly is: [MTP-June, 2024]

- (a) 6.14% (b) 6.07%
(c) 6.08% (d) 6.09%

24. Find the effective rate of interest if an amount 30,000 deposited in a bank for 1 year at the rate of 10% per annum compounded semi-annually. [MTP-June, 2022]

- (a) 10.05% (b) 10.10%
(c) 10.20% (d) 10.25%

25. The nominal rate of interest is 10% per annum. The interest is compounded quarterly, then the effective rate of interest per annum will be; [PYQ-Dec., 2023]

- (a) 10% (b) 10.10%
(c) 10.25% (d) 10.38%

Future Value of Annuity

26. The future value of an annuity of ₹5,000 is made annually for 8 years at interest rate of 9% compounded annually is [Given that, $(1.09)^8 = 1.99256$] [MTP-June, 2022]

- (a) ₹55,142.22
(b) ₹65,142.22
(c) ₹65,532.22
(d) ₹57,425.22

27. In an account paying interest @9% per year compounded monthly, Rs. 200 is invested at the end of each month. What is the future value of this annuity after 10th payment?

[Where, $(1.0075)^{10} = 1.0775$] [PYQ-Sept., 2024]

- (a) Rs. 1022 (b) Rs. 2066
(c) Rs. 2044 (d) Rs. 2155

28. How much money is required to be invested every year as to accumulate ₹6,00,000 at the end of 10 years, if interest is compounded annually at 10% rate of interest. [Given: $(1.1)^{10} = 2.59734$]

[MTP-June, 2024]

- (a) ₹37,467 (b) ₹37,476
(c) ₹37,647 (d) ₹37,674

29. How much amount is required to be invested every year so as to accumulate Rs. 30,000 at the end of 10 years if the interest compounded annually at 10%? [Given; $A(10, 0.1) = 15.9364$]

[PYQ-Sept., 2024]

- (a) Rs. 1882.36 (b) Rs. 1828.30
(c) Rs. 1832.65 (d) Rs. 1853.65

30. What will be the future value of an annuity ₹2500 made annually for 12 years at an interest rate of 5% compounded annually? If $(1.05)^{12} = 1.7958$

[PYQ-Dec., 2023]

- (a) ₹37588.58 (b) ₹39790.00
(c) ₹40873.13 (d) ₹42603.68

31. Suppose Mr. X invested ₹5000 every year starting from today in mutual fund for next 10 years. Assuming that average return compounded annually is at 18% per annum. What is the future value?

[PYQ-Dec., 2023]

- (a) ₹1,83,677.68 (b) ₹1,38,678.85
(c) ₹1,83,776.53 (d) ₹1,38,774.55

Present Value of Annuity

32. Calculate the present value of ₹2000 to be required after 10 years compounded annually at 5% per annum. [Given $(1.05)^{10} = 1.62889$]

[PYQ-Dec., 2023]

- (a) ₹1227.82 (b) ₹1282.48
(c) ₹1328.35 (d) ₹1822.65

33. Mr. A borrows ₹5,00,000 to buy a house. If he pays equal instalments for 20 years and 10% interest on outstanding balance, then what will be the equal annual instalment? [MTP-June, 2024]

- (a) ₹58,239.84
(b) ₹58,729.84
(c) ₹68,729.84
(d) None of these

34. Suppose your parent decides to open a PPF account in a bank towards your name with ₹10,000 every year starting from today for next years. When you receive and get 8.5% per annum interest rate compounded annually. What is the present value of this annuity?

[MTP-June, 2022]

- (a) ₹83,042 (b) ₹80,900
(c) ₹90,100 (d) None

Applications

35. Determine the present value of perpetuity of ₹50,000 per month at the rate interest 12% per annum is

[MTP-June, 2022]

- (a) ₹45,00,000
(b) ₹50,00,000
(c) ₹55,00,000
(d) ₹60,00,000

36. A perpetuity has a cash flow of Rs. 625 and a required rate of return of 8%. If the cash flow is expected to grow at a constant rate of 4% per year, then the intrinsic value of this perpetuity (present value of growing perpetuity) is;

[PYQ-Sept., 2024]

- (a) Rs. 15,625 (b) Rs. 13,000
(c) Rs. 14,250 (d) Rs. 16,667

37. The Earning Per Share (EPS) of a company for five years is given below:

Year	2019	2020	2021	2022	2023
EPS	40	25	40	60	90

Calculate the compounded Annual Growth Rate (CAGR) of EPS.

[PYQ-Sept., 2024]

- (a) 24.47% (b) 23.47%
(c) 22.47% (d) 21.47%

38. If the initial investment of ₹4,00,000 becomes ₹6,00,000 in 24 months, then the compound Annual Growth Rate (CAGR) is; [PYQ-Dec., 2023]

- (a) 30.33% (b) 22.4%
(c) 19.46% (d) 14.47%

ANSWER KEY

- | | | | | | | | | | |
|---------|---------|---------|---------|---------|---------|---------|---------|---------|---------|
| 1. (c) | 2. (b) | 3. (b) | 4. (a) | 5. (c) | 6. (a) | 7. (d) | 8. (c) | 9. (a) | 10. (a) |
| 11. (b) | 12. (c) | 13. (a) | 14. (d) | 15. (a) | 16. (c) | 17. (b) | 18. (b) | 19. (b) | 20. (a) |
| 21. (a) | 22. (a) | 23. (a) | 24. (d) | 25. (d) | 26. (a) | 27. (b) | 28. (c) | 29. (a) | 30. (b) |
| 31. (d) | 32. (a) | 33. (b) | 34. (c) | 35. (b) | 36. (a) | 37. (c) | 38. (b) | | |

HINTS & SOLUTIONS

1. (c) If P be the sum of money then amount (A) will be $4P$.

Therefore, $S.I. = A - P = 4P - P = 3P$

We know that,

$$S.I. = \frac{P \times R \times T}{100}$$

$$\Rightarrow 3P = \frac{P(12)(T)}{100}$$

$$\Rightarrow 3 = \frac{12T}{100}$$

$$\Rightarrow T = \frac{300}{12} = 25$$

Therefore, the required time is 25 years.

2. (b) According to question, we have

$P = ₹12,000$, $A = ₹14,880$ and $R = 6\%$ p.a.

$$\Rightarrow S.I. = ₹14,880 - ₹12,000 = ₹2880$$

We know,

$$S.I. = \frac{P \times R \times T}{100}$$

$$\Rightarrow 2880 = \frac{12000 \times 6 \times T}{100}$$

$$\Rightarrow T = \frac{2880 \times 100}{12000 \times 6}$$

$$\Rightarrow T = 4 \text{ years}$$

Therefore, the required time period is 4 years.

3. (b) Given equation, $x^2 - 11x + 30 = 0$

$$\Rightarrow x^2 - 6x - 5x + 30 = 0$$

$$\Rightarrow x(x - 6) - 5(x - 6) = 0$$

$$\Rightarrow (x - 5)(x - 6) = 0$$

$$\Rightarrow x = 5, x = 6$$

Since, the rate and time are roots of the given equation thus,

$$\text{Simple Interest} = \frac{P \times R \times T}{100}$$

$$= \frac{(2000)(6)(5)}{100} = 600$$

Therefore, the simple interest is ₹600.

4. (a) Given, Total simple interest earned in 6 years = ₹1520

According to the question,

Rate of interest for 2 years, $R_1 = 3\%$ p.a.

Rate of interest for next 3 years, $R_2 = 8\%$ p.a.

Rate of interest for next 1 year, $R_3 = 10\%$ p.a.

In P be the money he deposited (i.e. Principal), then

$$\frac{P \times R_1 \times T_1}{100} + \frac{P \times R_2 \times T_2}{100} + \frac{P \times R_3 \times T_3}{100} = 1520$$

$$\Rightarrow \frac{P \times 3 \times 2}{100} + \frac{P \times 8 \times 3}{100} + \frac{P \times 10 \times 1}{100} = 1520$$

$$\Rightarrow \frac{6P}{100} + \frac{24P}{100} + \frac{10P}{100} = 1520$$

$$\Rightarrow \frac{40P}{100} = 1520$$

$$\Rightarrow P = 3800$$

Therefore, the man deposited ₹3800.

5. (c) According to question, we have

$A = 2P$, where P is the Principal and Rate of Interest (R) = 12.5%

We know,

$$S.I. = \frac{P \times R \times T}{100}$$

$$\Rightarrow P = \frac{P \times 12.5 \times T}{100} \Rightarrow T = \frac{1 \times 100}{12.5}$$

$$\Rightarrow T = 8 \text{ years}$$

Therefore, the required time period is 8 years.

6. (a) Given, $P = ₹1,000$, $A = ₹1331$ and $n = 3$ years

Let the rate of interest be $r\%$

Since, the interest is compounded yearly, thus

$$A = P \left(1 + \frac{r}{100} \right)^n$$

$$\Rightarrow 1331 = 1000 \left(1 + \frac{r}{100} \right)^3$$

$$\Rightarrow \frac{1331}{1000} = \left(1 + \frac{r}{100} \right)^3$$

$$\Rightarrow \left(\frac{11}{10} \right)^3 = \left(1 + \frac{r}{100} \right)^3$$

$$\Rightarrow \frac{11}{10} = 1 + \frac{r}{100}$$

$$\Rightarrow \frac{r}{100} = \frac{r}{100}$$

$$\Rightarrow r = 10$$

Therefore, the required rate of interest is 10%

7. (d) Given; $P = \text{Rs. } 40,000$, $R = 12\%$ and $T = 6$ months $= \frac{6}{12} = \frac{1}{2}$ years

Since, it is compounded quarterly thus $n = 4$

$$\text{Therefore, Amount} = 40,000 \left(1 + \frac{12}{400} \right)^2$$

$$= 40,000 \left(\frac{103}{100} \right)^2$$

$$= \text{Rs. } 42,436$$

$$\begin{aligned} \text{Therefore, C.I} &= \text{Rs. } 42,436 - \text{Rs. } 40,000 \\ &= \text{Rs. } 2,436 \end{aligned}$$

Trick:

The required compound interest $= 40,000 + 3\% + 3\% - 40,000 = \text{Rs. } 2,436$

8. (c) According to question, we have

$$P = ₹15,625, t = 9 \text{ months} = \frac{9}{12} \text{ years}$$

$$\Rightarrow n = t \times m = 4 \times \frac{9}{12} = 3$$

And, $r = 16\%$

We know that,

$$C.I = P \left[\left(1 + \frac{r}{m} \right)^n - 1 \right]$$

$$\Rightarrow C.I = 15625 \left[\left(1 + \frac{16}{400} \right)^3 - 1 \right]$$

$$\Rightarrow C.I = 15625 [(1.04)^3 - 1]$$

$$\Rightarrow C.I = ₹1951$$

Therefore, the required interest is ₹1951.

9. (a) Given; $r = 6\frac{1}{4}\% = \frac{25}{4}\%$

$$\text{Thus, } i = \frac{r}{100} = \frac{\frac{25}{4}}{100} = \frac{25}{400}$$

Therefore, $A = P(1 + i)^n$

$$\Rightarrow 491300 = P \left(1 + \frac{25}{100} \right)^3$$

$$\Rightarrow 491300 = P \left(\frac{5}{4} \right)^3$$

$$\Rightarrow P = \text{Rs. } 4,09,600$$

10. (a) Given, Present value of scooter = ₹7290

Rate of depreciation, $R\% = 10\%$

Let P be the value of scooter 3 years ago, then

$$7290 = P \left(1 - \frac{10}{100} \right)^3$$

$$\Rightarrow 7290 = P(1 - 0.10)^3$$

$$\Rightarrow P = \frac{7290}{(1 - 0.10)^3}$$

$$\Rightarrow P \approx ₹10,000$$

11. (b) Given; Annual increase in population = 2%

Let the initial population be P and at the end of n years, the population increase by 40% i.e.,

$$A = P + 40\% \text{ of } P = P + \frac{40}{100}P = 1.40P$$

We know that,

$$A = P \left(1 + \frac{R}{100} \right)^n$$

$$\Rightarrow 1.40P = P \left(1 + \frac{2}{100} \right)^n$$

$$\Rightarrow 1.40 = \left(1 + \frac{2}{100} \right)^n$$

$$\Rightarrow 1.40 = (1.02)^n$$

$$\Rightarrow n = \frac{\log 1.4}{\log 1.02}$$

$$\Rightarrow n = \frac{0.146}{0.0086}$$

$$\Rightarrow n = 16.97 = 17 \text{ years (approx)}$$

Hence, the correct answer is option (b).

12. (c) Given, Cost value = ₹9,000, Scrap value = ₹23,240

Rate of depreciation = 10%

Let for n years, the machine was put to use.

We know that,

$$\text{Scrap value} = \text{Cost value} \times \left(1 - \frac{R}{100}\right)^n$$

$$\Rightarrow 9000 = 23240 \left(1 - \frac{10}{100}\right)^n$$

$$\Rightarrow \frac{9000}{23240} = (0.9)^n$$

$$\Rightarrow 0.3873 = (0.9)^n$$

Taking log on both sides, we get

$$\log(0.3873) = n \log(0.9)$$

$$\Rightarrow n = \frac{\log(0.3873)}{\log(0.9)}$$

$$\Rightarrow n = 9 \text{ years (Approx)}$$

Therefore, for 9 years, the machine was put to use. Hence, the correct answer is option (c).

13. (a) Given, Present population of a town = 25,000
Since, it grows at the rate of 4%, 5%, 8% during 1st year, 2nd year, 3rd year respectively, thus population after 3 years will be given by:

$$\begin{aligned} P \left(1 + \frac{r_1}{100}\right) \left(1 + \frac{r_2}{100}\right) \left(1 + \frac{r_3}{100}\right) \\ = 25000 \left(1 + \frac{4}{100}\right) \left(1 + \frac{5}{100}\right) \left(1 + \frac{8}{100}\right) \\ = 25000(1.04)(1.05)(1.08) = 29484 \end{aligned}$$

Calculator Trick:

Population after 3 years will be given by;

$$2500 + 4\% + 5\% + 8\% = 29484.$$

14. (d) According to question, we have

$$P = ₹6000, t = 1\frac{1}{4} = \frac{5}{4} \text{ years \& } r = 8\% \text{ p.a.}$$

Since, the interest is compounded quarterly, thus $m = 4$

We know that,

$$C.I = P \left[\left(1 + \frac{r}{m}\right)^{t \times m} - 1 \right]$$

$$\Rightarrow C.I = 600 \left[\left(1 + \frac{0.08}{4}\right)^{\frac{5}{4} \times 4} - 1 \right]$$

$$\Rightarrow C.I = 600[(1.02)^5 - 1]$$

$$\Rightarrow C.I = 624.48$$

Therefore, the required interest is ₹624.48.

15. (a) Given; Present population (P) = 1,00,000

$$r_1 = 3\%, r_2 = 4\% \text{ and } r_3 = 5\%$$

Therefore, the population after 3 years will be given by;

$$\begin{aligned} P(1 + r_1)^1(1 + r_2)^1(1 + r_3)^1 \\ = 100000(1 + 0.03)(1 + 0.4)(1 + 0.05) \\ = 1,12,476 \end{aligned}$$

Therefore, the required population is 1, 12,476

16. (c) Given, Difference between compound interest and simple interest = ₹10

$$C.I. - S.I. = Pi^2$$

$$\Rightarrow 10 = P \times \left(\frac{10}{100}\right)^2$$

$$\Rightarrow P = \frac{10}{(0.1)^2}$$

$$\Rightarrow P = 1000$$

Therefore, the required sum is ₹1000.

17. (b) According to the question,

$$C.I - S.I = \text{Rs. } 480$$

We know that,

$$C.I - S.I = Pi^2$$

$$\Rightarrow 480 = 3,00,00i^2$$

$$\Rightarrow i^2 = 0.0016$$

$$\Rightarrow i = 0.04$$

$$\Rightarrow r = 4\%$$

18. (b) We know that,

Difference between compound interest and simple interest for two years is given by Pr^2 .

$$\Rightarrow Pr^2 = 372$$

$$\Rightarrow P(0.10)^2 = 372$$

$$\Rightarrow P = \frac{372}{(0.10)^2}$$

$$\Rightarrow P = 37,200$$

Therefore, the required principal amount is ₹37,200.

19. (b) According to question, we have

$$A = P + \frac{60}{100}P = 1.6P$$

We know,

$$A = P(1 + it)$$

$$\Rightarrow 1.6P = P(1 + i \times 6)$$

$$\Rightarrow 1.6 = (1 + 6i)$$

$$\Rightarrow 6i = 0.6$$

$$\Rightarrow i = 0.1$$

$$\Rightarrow \frac{r}{100} = 0.1$$

$$\Rightarrow r = 10\%$$

Therefore, the compound interest of ₹12,000 after 3 years at the same rate is given by

$$C.I = P[(1 + i)^n - 1]$$

$$\Rightarrow C.I = 1200[(1 + 0.10)^3 - 1]$$

$$\Rightarrow C.I = ₹3972$$

20. (a) According to question, we have

$$P = ₹50,000, t = 2\frac{1}{2} \text{ years} \text{ \& } r = 12\%$$

Since, the interest is compounded half yearly, thus $m = 2$

$$\Rightarrow n = t \times m = \frac{5}{2} \times 2 = 5$$

We know that,

Maturity value is given by;

$$P(1 + i)^n$$

$$= 50000 \left(1 + \frac{12}{2 \times 100}\right)^5$$

$$= 50000(1.06)^5$$

$$= 66910$$

Therefore, the required value is ₹66910.

21. (a) We know that,

Effective rate of interest,

$$E = \left[\left(1 + \frac{r}{m}\right)^m - 1 \right] \times 100$$

where, r is rate of interest in decimal and m is the number of conversion period. Therefore, the effective rate of interest does not depend upon the Principal.

22. (a) Since, the interest is payable quarterly thus

Effective rate of interest is given by;

$$E = [(1 + i)^n - 1] \times 100\%$$

$$\Rightarrow E = \left[\left(1 + \frac{10}{4 \times 100}\right)^4 - 1 \right] \times 100\%$$

$$\Rightarrow E = \left[\left(1 + \frac{1}{40}\right)^4 - 1 \right] \times 100\%$$

$$\Rightarrow E = 10.38\%$$

23. (a) According to question, we have

$$r = 6\% = 0.06 \text{ and } m = 4$$

Therefore, Effective rate of interest is given by

$$\left[\left(1 + \frac{r}{m}\right)^m - 1 \right] \times 100\%$$

$$= \left[\left(1 + \frac{0.06}{4}\right)^4 - 1 \right] \times 100\%$$

$$= 0.06136 \times 100\%$$

$$= 6.14\% \text{ (Approx)}$$

24. (d) We know that,

Effective rate of interest is given by:

$$E = [(1 + i)^n - 1] \times 100$$

$$\Rightarrow E = \left[\left(1 + \frac{10}{2 \times 100}\right)^2 - 1 \right] \times 100$$

$$\Rightarrow E = [(1 + 0.05)^2 - 1] \times 100$$

$$\Rightarrow E = [(1.05)^2 - 1] \times 100$$

$$\Rightarrow E = 10.25\%$$

25. (d) According to question, we have

$$r = 10\% = 0.10 \text{ and } m = 4$$

Therefore, Effective rate of interest is given by

$$\left[\left(1 + \frac{r}{m}\right)^m - 1 \right] \times 100\%$$

$$= \left[\left(1 + \frac{0.10}{4}\right)^4 - 1 \right] \times 100\%$$

$$= 10.38\% \text{ (Approx)}$$

26. (a) Given, $A = ₹5,000$, $n = 8$ years, $r = 9\%$ & $c = 1$

We know that,

Future value of an annuity is given by:

$$FV = \frac{A[(1+i)^n - 1]}{i}$$

$$\Rightarrow FV = \frac{5000[(1+0.09)^8 - 1]}{0.09}$$

$$\Rightarrow FV = \frac{5000[1.99256 - 1]}{0.09}$$

$$\Rightarrow FV = 55,142.22$$

Therefore, the future value of the annuity is ₹55,142.22

27. (b) Given, $A = \text{Rs. } 200$, $i = \frac{9}{1200}$ and $n = 10$

$$\text{Therefore, } F.V. = \frac{200}{\frac{9}{1200}} \left[\left(1 + \frac{9}{1200} \right)^{10} - 1 \right]$$

$$= \frac{200 \times 1200}{9} \left[\left(\frac{403}{400} \right)^{10} - 1 \right]$$

$$= \frac{200 \times 1200}{9} \left[(1.0075)^{10} - 1 \right]$$

$$= \text{Rs. } 2066$$

28. (c) According to question, we have

$$F.V. = ₹6,00,000, i = 10\% \text{ and } n = 10 \text{ years}$$

We know that,

$$F.V. = \frac{A}{i} [(1+i)^n - 1]$$

$$\Rightarrow 600000 = \frac{A}{0.10} [(1+0.10)^{10} - 1]$$

$$\Rightarrow A = \frac{600000 \times 0.10}{[(1.10)^{10} - 1]}$$

$$\Rightarrow A = ₹37,562.44$$

$$\Rightarrow A \approx ₹37,647$$

29. (a) According to the question

$$F.V. = \text{Rs. } 30,000, i = 10\% = 0.01, n = 10 \text{ years}$$

Therefore,

$$F.V. = \frac{A}{i} [(1+i)^n - 1]$$

$$\Rightarrow 30,000 = \frac{A}{0.1} \left[\left(1 + \frac{10}{100} \right)^{10} - 1 \right]$$

$$\Rightarrow 30,000 = \frac{A}{0.1} [(0.1)^{10} - 1]$$

$$\Rightarrow A = \frac{30000 \times 0.1}{[(0.1)^{10} - 1]}$$

$$\Rightarrow A = \text{Rs. } 1882.36$$

Trick:

$$F.V. = \frac{30,000}{15.9374}$$

$$\Rightarrow F.V. = \text{Rs. } 1882.36$$

30. (b) According to question, we have

$$R = ₹2500$$

$$t = 12 \text{ years}$$

$$\Rightarrow n = t \times m = 12 \times 1 = 12$$

$$\& i = 5\% \text{ p.a.}$$

We know that,

Future value of an annuity is given by;

$$F.V. = R \left\{ \frac{(1+i)^n - 1}{i} \right\}$$

$$\Rightarrow F.V. = 2500 \left\{ \frac{\left(1 + \frac{5}{100} \right)^{12} - 1}{\frac{5}{100}} \right\}$$

$$\Rightarrow F.V. = \left\{ \frac{(1.05)^{12} - 1}{0.05} \right\}$$

$$\Rightarrow F.V. = \left\{ \frac{1.7958 - 1}{0.05} \right\}$$

$$\Rightarrow F.V. = ₹39,790$$

31. (d) Given;

$$R = ₹5000$$

$$t = 10 \text{ years}$$

$$\Rightarrow n = t \times m = 10 \times 1 = 10$$

$$t = 18\%$$

Since, that the annuity is starting from today thus it is an Annuity Due/Immediate.

We know,

$$F.V. = R \left\{ \frac{(1+i)^{n+1} - 1}{i} \right\} (1+i)$$

$$\Rightarrow F.V. = 5000 \left\{ \frac{(1+0.18)^{10+1} - 1}{0.18} \right\} (1+0.18)$$

$$\Rightarrow F.V. = 5000 \left\{ \frac{(1.18)^{11} - 1}{0.18} \right\} (1.18)$$

$$\Rightarrow F.V. = 138,774.55 \text{ (Approx)}$$

32. (a) According to question, we have

$$F.V = ₹2000, t = 10 \text{ years and } r = 5\% \text{ p.a.}$$

$$\Rightarrow n = t \times m = 10 \times 1 = 10$$

Therefore, the present value is given by

$$P.V. = F.V.(1 + i)^{-n}$$

$$\Rightarrow P.V. = 2000 \left(1 + \frac{5}{100} \right)^{-10}$$

$$\Rightarrow P.V. = 2000(1.05)^{-10}$$

$$\Rightarrow P.V. = ₹1227.82$$

33. (b) Given; $P.V. = ₹5,00,000, i = 10\%$ and $n = 20$

We know that,

$$P.V. = \frac{A[1 - (1 + i)^{-n}]}{i}$$

$$\Rightarrow 500000 = \frac{A[1 - (1 + 0.10)^{-20}]}{0.10}$$

$$\Rightarrow A = \frac{500000 \times 0.1}{(1 - (1.1)^{-20})}$$

$$\Rightarrow A = 58,729.84$$

Therefore, the equal annual instalment is ₹58,729.84

34. (c) Given, $A = ₹10,000, r = 8.5\%$ p.a., $c = 1, n = 12$ years

$$\Rightarrow i = \frac{8.5}{100} = 0.085$$

Since, the annuity is starting from today i.e., it is the case of annuity immediate.

Therefore, the present value of annuity is given by:

$$PV = \frac{A \left[\frac{(1+i)^n - 1}{i} \right]}{i(1+i)^n} \times (1+i)$$

$$= \frac{1000 \left[\frac{(1+0.085)^{15} - 1}{0.085} \right]}{0.085 + (1+0.085)^{15}} \times (1+0.085)$$

$$= \frac{10000 \left[\frac{(1.085)^{15} - 1}{0.085} \right]}{(1.085)^{15}} \times (1.085)$$

$$= 90,100 \text{ (Approx)}$$

Hence, the present value of this annuity is Rs. 90,100

35. (b) According to question, we have

$$A = ₹50000 \text{ and } i = 12\% \text{ p.a.}$$

We know that,

$$\text{Present value of perpetuity} = \frac{A}{i}$$

$$= \frac{50000}{12} = \frac{50000}{12} \times 1200$$

$$= \frac{50000 \times 100}{12}$$

$$= ₹50,00,000$$

Therefore, the present value of perpetuity is ₹50,00,000

36. (a) According to the question,

$$R = \text{Rs. } 625, i = 0.08 \text{ and } g = 0.04$$

$$\text{Therefore, } PVA = \frac{R}{i - g}$$

$$= \frac{625}{0.08 - 0.04} = \frac{625}{0.04}$$

$$= \text{Rs. } 15,625$$

37. (c) According to data,

Year	2019	2020	2021	2022	2023
EPS	40	25	40	60	90

$$\text{Therefore, } CAGR = \left(\frac{90}{40} \right)^{\frac{1}{4}} - 1$$

$$= (2.25)^{\frac{1}{4}} - 1$$

$$= 22.47\%$$

38. (b) According to question, we have

$$V(t_n) = 6,00,000 \text{ and } V(t_0) = 4,00,000$$

$$\text{Also, } t = 24 \text{ months} = 2 \text{ years}$$

We know,

$$CAGR(t_0, t_n) = \left[\left(\frac{V(t_n)}{V(t_0)} \right)^{\frac{1}{t_n - t_0}} - 1 \right] \times 100\%$$

$$\Rightarrow CAGR = \left[\left(\frac{600000}{400000} \right)^{\frac{1}{2-0}} - 1 \right] \times 100\%$$

$$\Rightarrow CAGR = \left[(1.5)^{\frac{1}{2}} - 1 \right] \times 100\%$$

$$\Rightarrow CAGR = 22.4\% \text{ (Approx)}$$



Chapter Wrap-up Test

Ready to test your knowledge?

You've got 15 questions and 20 minutes – go for it!

1. John deposited ₹40,000 in a bank for three years with the simple interest rate of 6% p.a. How much interest would he earn?
 (a) ₹4,100 (b) ₹5,400
 (c) ₹6,600 (d) ₹7,200
2. A person invested ₹8,000 at the rate of 10% compounded annually. Find the compound interest gained in 3 years.
 (a) ₹2684 (b) ₹10,648
 (c) ₹10,000 (d) ₹12,648
3. In how many years will a sum of money becomes four times at 12% p.a. simple interest?
 (a) 18 years (b) 21 years
 (c) 25 years (d) 28 years
4. The present value of a scooter is ₹7290. The rate of depreciation is 10%. What was its value 3 years ago?
 (a) ₹10,000 (b) ₹10,010
 (c) ₹9990 (d) ₹12,000
5. What will be the population after 3 years, when present population is 1,00,000 and the population increase at 3% in 1st year, at 4% second year and 5% in third year?
 (a) 1,12,476 (b) 1,15,476
 (c) 1,20,576 (d) 1,25,600
6. Find the effective rate of interest if an amount of 30,000 deposited in a bank for 1 year at the rate of 10% per annum compounded semi-annually.
 (a) 10.05% (b) 10.10%
 (c) 10.20% (d) 10.25%
7. The difference between simple interest and compound interest on a certain for 2 years at 10% p.a. is ₹10. Find the sum.
 (a) ₹1010 (b) ₹1095
 (c) ₹1000 (d) ₹990
8. Rajan is planning for his retirement and desires to receive a monthly payment of ₹7,500. He wishes to ensure that this monthly payment continues to be passed on to future generations even after his demise. With an expected interest rate of 5% compounded annually, how much does Rahul need to set aside to achieve his perpetuity goal?
 (a) ₹21,00,000 (b) ₹15,00,000
 (c) ₹24,00,000 (d) ₹18,00,000
9. Determine the present value of perpetuity of ₹50,000 per month at the rate interest 12% per annum is
 (a) ₹45,00,000
 (b) ₹50,00,000
 (c) ₹55,00,000
 (d) ₹60,00,000
10. The future value of an annuity of ₹5,000 is made annually for 8 years at interest rate of 9% compounded annually is [Given that $(1.09)^8 = 1.99256$]
 (a) ₹55,142.22 (b) ₹65,142.22
 (c) ₹65,532.22 (d) ₹57,425.22
11. Prerna bought a property by paying ₹80,00,000 down payment and ₹20,000 at the end of each year till the perpetuity, assuming the rate of interest as 20%, the present value of property (in ₹) is given as
 (a) ₹1,00,000
 (b) ₹20,00,000
 (c) ₹61,00,000
 (d) ₹81,00,000
12. The Earning Per Share (EPS) of a company for five years is given below:

Year	2019	2020	2021	2022	2023
EPS	40	25	40	60	90

 Calculate the compounded annual Growth Rate
 (a) 24.47% (b) 23.47%
 (c) 22.47% (d) 21.47%

13. Suppose your parent decides to open a PPF account in a bank towards your name with ₹10,000 every year starting from today for next 15 years. When you receive and get 8.5% per annum interest rate compounded annually. What is the present value of this annuity?

- (a) ₹83,042 (b) ₹80,900
(c) ₹90,100 (d) None of these

14. Ankita deposits ₹6000 at the start of each quarter in his savings account. If the accountant earns interest 6% per annum compounded quarterly, how much money (in ₹) will he have at the end of 5 years?

- (a) ₹120,300 (b) ₹130,175
(c) ₹140,823 (d) ₹150,805

15. A company is considering buying a piece of equipment for ₹75,000 or leasing it for 5 years at an annual rent of ₹18,000. If the company's cost of capital is 12%, which option is more financially attractive?

- (a) Leasing the equipment is more financially attractive
(b) Buying the equipment is more financially attractive
(c) Both options have the same cost
(d) Cannot be determine

ANSWER KEY

1. (d) 2. (a) 3. (c) 4. (a) 5. (a) 6. (d) 7. (c) 8. (d) 9. (b) 10. (a)
11. (d) 12. (c) 13. (c) 14. (c) 15. (a)





Basic Concepts of Permutations and Combinations

Cheat Sheet by Anurag Sir

PERMUTATION & COMBINATION

Multiplication theorem
(Fundamental Principle of Counting)



If one event can be performed in 'm' ways and another event can be performed in 'n' ways. Then Total ways of doing two events one by one = $m \times n$

Factorial (!)

$n!$ = Product of first 'n' natural numbers

Eg. $4! = 4 \times 3 \times 2 \times 1 = 24$

Eg. $8! = 8 \times 7 \times \dots \times 3 \times 2 \times 1 = 40320$

$0! = 1$

$n! = n(n-1)(n-2)(n-3) \dots$ 3.2.1

$(2n)! = 2n(2n-1)(2n-2) \dots$ 3.2.1

$(n+2)! = (n+2)(n+1)n(n-1) \dots$ 3.2.1

$1(1!) + 2(2!) + 3(3!) + \dots + n(n!) = (n+1)! - 1$

Permutations

Arrangement of elements where order of elements is important.

E.g.: Elements: 1, 2, 3

Permutations: 123, 132, 213, 231, 312, 321

- Total permutations of 'n' elements when 'r' elements are used at a time

$${}^n P_r = \frac{n!}{(n-r)!}$$

Where, $0 \leq r \leq n$

- When some elements repeat with frequencies f_1, f_2 and f_3 .

Then total permutations = $\frac{n!}{f_1! f_2! f_3!}$

Circular Permutations

- Total circular permutations of 'n' elements = $(n-1)!$
- Total circular permutations when in each permutations have different neighbour or necklace formation = $\frac{(n-1)!}{2}$

→ Sum of all permutations when some digits are given

= [Sum of given digits] $\times \frac{n!}{n} \times 1111 \dots n$ times

COMBINATIONS

Selection of elements where order of selection is not important:

Eg.: Elements: a, b, c

Selection of 2 elements ab, ac and bc

$${}^n C_r = \frac{{}^n P_r}{r!} \text{ or } {}^n C_r = \frac{n!}{r!(n-r)!}$$

- ${}^n C_0 = 1$
- ${}^n C_n = 1$
- ${}^n C_1 = n$
- ${}^n C_2 = \frac{n(n-1)}{2}$
- ${}^n C_r = {}^n C_{n-r}$
- ${}^n C_r + {}^n C_{r+1} = {}^{n+1} C_{r+1}$
- If ${}^n C_a = {}^n C_b$
Then, $a = b$ or $a + b = n$
- ${}^n C_0 + {}^n C_1 + {}^n C_2 + \dots + {}^n C_n = (2)^n$
- ${}^n C_1 + {}^n C_2 + {}^n C_3 + \dots + {}^n C_n = (2)^n - 1$
- Total handshakes in a group of n person = ${}^n C_2$

□ Total diagonals in a polygon with n sides
 $= {}^n C_2 - n = \frac{n(n-3)}{2}$

□ When ' n ' non collinear points are given.

Then total lines = ${}^n C_2$

Total Triangles = ${}^n C_3$

□ When ' n ' points are given out of which ' m ' points are collinear then,

Total lines = ${}^n C_2 - {}^m C_2 + 1$

Total Triangles = ${}^n C_3 - {}^m C_3$

QUESTIONS

Fundamental Principle of Counting

1. There are 10 flights operating between City A and City B. Find the number of ways in which a person can travel from City A and City B and return by different flight. [PYQ-June 2022, July 2021]

- (a) 80 (b) 95
 (c) 90 (d) 78

2. A multiple choice test contains five questions and each question has four possible options. How many different answer keys are possible?

[PYQ-June 2022, Nov., 2021]

- (a) 512 (b) 1024
 (c) 20 (d) 625

3. A person can go from place 'A' to 'B' by 11 different modes of transport but is allowed to return back to 'A' by any mode other than the one earlier. The number of different ways, the entire journey can be complete is [PYQ-July, 2021]

- (a) 110 (b) 10^{10}
 (c) 9^5 (d) 10^9

4. There are 12 questions to be answered in Yes or No. In how many ways this can be answered?

[MTP-June, 2024]

- (a) 1021 (b) 2048
 (c) 4096 (d) None of the above

5. How many numbers of 3 digits can be made by using digits 3, 5, 6, 7 and 8, no digit being repeated? [MTP-June 2023]

- (a) 120 (b) 60
 (c) 100 (d) None

6. How many 3 digits odd number can be formed using the digits 5, 6, 7, 8, 9, if the digits can be repeated? [PYQ-Dec., 2022]

- (a) 55 (b) 75
 (c) 65 (d) 85

The Factorial

7. The value of N in $\frac{1}{7!} + \frac{1}{8!} = \frac{N}{9!}$ is [PYQ-Nov., 2018]

- (a) 81 (b) 64
 (c) 78 (d) 89

8. If $\frac{1}{9!} + \frac{1}{10!} = \frac{x}{11!}$, then the value of x is [MTP-Sept., 2024]

- (a) 211 (b) 122
 (c) 1331 (d) None of these

Permutations

9. Find ' n ' if ${}^n P_2 = 72$. [PYQ-Dec., 2023]

- (a) 12 (b) 36
 (c) 24 (d) 9

10. If $\frac{n!}{10} = {}^{n-1} P_{n-3}$, then $n =$ [PYQ-June, 2022]

- (a) 5 (b) 6
 (c) 7 (d) 8

11. If 12 schools teams are participating in a quiz contest, then the number of ways first, second and third position may be won is

[MTP-Jan., 2025]

- (a) 1230 (b) 1320
 (c) 3210 (d) None of these

12. If six times the number of permutation of n things taken 3 at a time is equal to seven times the number of permutation of $(n-1)$ things taken 3 at a time, find n . [MTP-May, 2025]

- (a) 21 (b) 20
 (c) 15 (d) 27

13. The number of ways the letters of the word 'TRIANGLE' to be arranged so that word 'ANGLE' will be always present in [MTP-May, 2025]

- (a) 20 (b) 60
 (c) 24 (d) 32

14. The number of ways the letter of the word 'COMPUTER' can be rearranged is
[MTP-Jan., 2025]
(a) 40,320 (b) 40,319
(c) 40,318 (d) None of these
15. The number of four letter words can be formed using the letters of the word 'DICTIONARY' is
[PYQ-Dec., 2021]
(a) 5040 (b) 720
(c) 90 (d) 30240
16. In how many different ways can five persons stand in a line for a group photograph?
[MTP-May, 2025]
(a) 90 (b) 120
(c) 150 (d) 160
17. How many ways can 5 different trophies be arranged on a shelf if one particular trophy must always be in the middle? [PYQ-June, 2024]
(a) 24 (b) 48
(c) 120 (d) 144
18. The number of ways in which the letter of the word 'MOBILE' be arranged so that consonants always occupy the odd places is
[MTP-May, 2025]
(a) 36 (b) 63
(c) 30 (d) None of the
19. There are 5 speakers A,B, C, D and E. The number of ways in which A will speak always before B is
[MTP-May, 2025]
(a) 24 (b) $\angle 4 \times \angle 2$
(c) $\angle 5$ (d) None of these
20. The number of words that can be formed using the letters of 'PETROL' such that words do not have "P" in the first position is
[PYQ-Dec., 2021]
(a) 720 (b) 120
(c) 600 (d) 540
21. The total number of arrangement of 8 persons of a board in a row with the President and the Vice-President occupying middle places is
[PYQ-June, 2022]
(a) 6! (b) 7!
(c) $6! \times 2!$ (d) $7! \times 2!$
22. In how many ways can 5 doctors, 4 Professors and 6 Auditors be seated in a row so that all person of the same profession sit together?
[PYQ-Jan., 2025, MTP-May, 2025]
(a) $3! \times 5! \times 4!$ (b) $3! \times 5!$
(c) $3! \times 5! \times 4! \times 6!$ (d) $3! \times 5! \times 6!$
23. How many 4 letter words with or without meaning can be formed out of the letter of the word 'LOGARITHMS', if repetition of letters is not allowed? [PYQ, June, 2022]
(a) 5040 (b) 7020
(c) 5400 (d) 30240
24. In how many ways of the word 'MATHEMATICS' be arranged so that the vowels always occur together? [MTP-June, 2023]
(a) $11! \times (2!)^3$ (b) $\frac{8! \times 4!}{(2!)^3}$
(c) $\frac{12!}{(2!)^3}$ (d) None of these
25. In how many ways can the letters of the word FAILURE be arranged so that the consonants may occupy only odd positions? [MTP-Jan., 2025]
(a) 576 (b) 476
(c) 376 (d) 276
26. In how many different ways can the letters of the word 'CORPORATIONS' be arranged so that the vowels always come together?
[PYQ-Dec., 2023]
(a) 810 (b) 1440
(c) 25200 (d) 50400
27. In _____ ways can 4 Americans and 4 English men be seated at a round table so that no 2 Americans may sit together? [MTP-May, 2025]
(a) $4! \times 3!$ (b) 4P_4
(c) $3 \times {}^4P_4$ (d) 4C_4
28. 5 persons are sitting in a round table in such a ways that Tallest person in always on the right side of the shortest person; the number of such arrangements is. [MTP-Jan, 2025]
(a) 6 (b) 8
(c) 24 (d) None of these
29. In how many ways can a party of 4 men and 4 women be seated at a circular table, so that no two women are adjacent? [MTP-Jan., 2025]
(a) 164 (b) 174
(c) 144 (d) 154

30. In how many ways can the letters of the word 'FAILURE' be arranged so that the consonants may occupy only odd positions?

[MTP-Jan., 2025]

- (a) 576 (b) 476
(c) 376 (d) 276

31. n articles are arranged in such a way that 2 particular articles never come together. The number of such arrangement is

[MTP-May, 2025]

- (a) $(n-2) \times (n-1)!$ (b) $(n-1) \times (n-2)!$
(c) $n!$ (d) None of these

Combinations

32. If ${}^{15}C_{3r} = {}^{15}C_{r+3}$, then 'r' is equal to

[PYQ-Dec., 2023]

- (a) 5 (b) 4
(c) 3 (d) 2

33. If ${}^{20}C_r = {}^{20}C_{r+6}$, then the value of r is

[MTP-Sept., 2024]

- (a) 10 (b) 7
(c) 11 (d) None of these

34. Out of 7 boys and 4 girls, a team of 5 is to be chosen. The number of teams such that each team includes at least one girl is

[PYQ-June, 2022, PYQ-Dec., 2020]

- (a) 440 (b) 441
(c) 414 (d) 484

35. A panel has total of 11 members including 5 males and 6 females. Find out the number of ways of picking 2 males and 3 females from the given panel team.

[PYQ-Jan., 2025]

- (a) 200 (b) 110
(c) 220 (d) 350

36. If there are 40 guests in a party. If each guest takes a shake hand with all the remaining guests. Then the total number of hands shake is

[PYQ-June, 2019]

- (a) 780 (b) 840
(c) 1560 (d) 1600

37. A fruit basket contains 7 apples, 6 bananas and 4 mangoes. How many selections of 3 fruits can be made so that all 3 are apples?

[PYQ-Dec., 2020]

- (a) 120 ways (b) 35 ways
(c) 168 ways (d) 70 ways

38. In how many ways can be interview panel of 3 members be formed from 3 engineers, 2 psychologists and 3 managers if at least 1 engineer must be included? [PYQ-Jan., 2025]

- (a) 15 (b) 30
(c) 46 (d) 45

39. 3 ladies and 3 gents can be seated at a round table so that any two and only two of the ladies sit together. The number of ways is

[MTP-May, 2025]

- (a) 70 (b) 27
(c) 72 (d) None of these

40. There are 20 points in a plane area. How many triangles can be formed by these points if 5 points are collinear? [PYQ-Dec., 2022]

- (a) 550 (b) 560
(c) 1130 (d) 1140

41. A committee of 3 members is formed from 5 women and 3 men in such a way that it consists of at least 2 members who are women. In how many different ways can it be done?

[PYQ-Jan., 2025]

- (a) 50 (b) 40
(c) 60 (d) 30

42. The number of triangles that can be formed by choosing the vertices from a set of 12 points, seven of which lie on the same straight line, is:

[MTP-Jan., 2025]

- (a) 185 (b) 175
(c) 115 (d) 105

43. Six points are marked on a straight line and five points are marked on another line which is parallel to the first line, how many straight lines, including the first two can be formed with these points? [June, 2022]

- (a) 28 (b) 30
(c) 32 (d) 34

44. An examination paper with 10 questions consists of 6 questions in Algebra and 4 questions in Geometry. At least one question from each section is to be attempted. In how many ways can this be done? [MTP-Jan., 2025]

- (a) 945 (b) 100
(c) 1000 (d) None of these

45. The way of selecting 4 letters of the word 'EXAMINATION' is [MTP-May, 2025]

- (a) 136 (b) 130
(c) 125 (d) None of these

ANSWER KEY

- | | | | | | | | | | |
|---------|---------|---------|---------|---------|---------|---------|---------|---------|---------|
| 1. (c) | 2. (b) | 3. (a) | 4. (c) | 5. (b) | 6. (b) | 7. (a) | 8. (d) | 9. (d) | 10. (a) |
| 11. (b) | 12. (a) | 13. (c) | 14. (b) | 15. (a) | 16. (b) | 17. (a) | 18. (a) | 19. (a) | 20. (c) |
| 21. (c) | 22. (c) | 23. (a) | 24. (b) | 25. (a) | 26. (d) | 27. (a) | 28. (a) | 29. (c) | 30. (a) |
| 31. (a) | 32. (c) | 33. (b) | 34. (b) | 35. (a) | 36. (a) | 37. (b) | 38. (c) | 39. (c) | 40. (c) |
| 41. (b) | 42. (a) | 43. (c) | 44. (a) | 45. (a) | | | | | |

HINTS & SOLUTIONS

1. (c) Given; Total Flight = 10

Suppose a person picks a flight, thus he has 10 options.

Now, for the flights to be different on returning he has 9 options left.

Therefore, the total ways = $10 \times 9 = 90$

Hence, the correct answer is option (c) i.e. 90.

2. (b) Given; Total question = 5

Since, each question has four possible options, thus the possible different answer key = $4^5 = 1024$

3. (a) Modes of transport while going A to B = 11

Modes of transport while going B to A = 10

Total ways = $11 \times 10 = 110$

Hence, the correct option is (a) i.e. 110.

4. (c) Given; Total number of question = 12

Since, each of the question can be answered in 2 ways (Yes or No)

Therefore, 12 questions can be answered in $2 \times 2 \times 2 \dots 12$ times

= 2^{12} ways

= 4096 ways

5. (b) Given digit; digits 3, 5, 6, 7 and 8

Since, no digit can be repeated thus the number of 3 digits can be formed in $5 \times 4 \times 3 = 60$ ways.

6. (b) Given digits; 5, 6, 7, 8, 9

\Rightarrow Total digits = 5

To form 3 digits odd number, the unit place can be filled in 3 ways (5, 7, 9)

Since, the digits can be repeated, thus the tens and hundreds place can be filled in 5 ways each.

Therefore, the total required ways = $5 \times 5 \times 3 = 75$.

7. (a) Given, $\frac{1}{7!} + \frac{1}{8!} = \frac{N}{9!}$

$$\Rightarrow \frac{1}{7!} + \frac{1}{8 \times 7!} = \frac{N}{9!}$$

$$\Rightarrow \frac{1}{7!} \left(1 + \frac{1}{8} \right) = \frac{N}{9!}$$

$$\Rightarrow \frac{1}{7!} \left(1 + \frac{1}{8} \right) = \frac{N}{9 \times 8 \times 7!}$$

$$\Rightarrow \frac{9}{8} = \frac{N}{72}$$

$$\Rightarrow N = 81$$

8. (d) Given, $\frac{1}{9!} + \frac{1}{10!} = \frac{x}{11!}$

$$\Rightarrow \frac{1}{9!} + \frac{1}{10 \times 9!} = \frac{x}{11 \times 10 \times 9!}$$

$$\Rightarrow \frac{1}{9!} \left(1 + \frac{1}{10} \right) = \frac{x}{11 \times 10 \times 9!}$$

$$\Rightarrow \left(1 + \frac{1}{10} \right) = \frac{x}{11 \times 10}$$

$$\Rightarrow \frac{11}{10} = \frac{x}{110}$$

$$\Rightarrow x = 11 \times 11 = 121$$

9. (d) Given; ${}^n P_2 = 72$

$$\Rightarrow \frac{n!}{(n-2)!} = 72$$

$$\Rightarrow \frac{n \times (n-1) \times (n-2)!}{(n-2)!} = 72$$

$$\Rightarrow n(n-1) = 9 \times 8$$

$$\Rightarrow n = 9$$

10. (a) Given; $\frac{n!}{10} = {}^{n-1}P_{n-3}$

$$\Rightarrow \frac{n!}{10} = \frac{(n-1)!}{(n-1-n+3)!}$$

$$\Rightarrow \frac{n \times (n-1)!}{10} = \frac{(n-1)!}{2!}$$

$$\Rightarrow \frac{n}{10} = \frac{1}{2}$$

$$\Rightarrow n = 5$$

11. (b) Given; Total number of schools = 12

Since, order matters thus by using permutation

Total number of ways first, second and third position may be won = ${}^{12}P_3$

$$= \frac{12!}{(12-3)!} \left[\because {}^n P_r = \frac{n!}{(n-r)!} \right]$$

$$= \frac{12!}{9!} = \frac{12 \times 11 \times 10 \times 9!}{9!} = 1320$$

Hence, option (b) is correct.

12. (a) According to question, we have

$$6 \times {}^n P_3 = 7 \times {}^{n-1} P_3$$

$$\Rightarrow 6 \times \frac{n!}{(n-3)! \times 3!} = 7 \times \frac{(n-1)!}{(n-4)! \times 3!}$$

$$\Rightarrow 6 \times \frac{n(n-1)!}{(n-3)(n-4)! \times 3!} = 7 \times \frac{(n-1)!}{(n-4)! \times 3!}$$

$$\Rightarrow 6 \times \frac{n}{(n-3)} = 7$$

$$\Rightarrow 6n = 7n - 21$$

$$\Rightarrow n = 21$$

13. (c) Given; In the word 'TRIANGLE' the word 'ANGLE' should always be present.

Thus, consider 'ANGLE' as one letter so the letters will be T, R, I and 'ANGLE'.

Therefore, there are 4 letters which can be arranged in $4!$ i.e. 24 ways.

Hence, option (c) is correct i.e., 24.

14. (b) Given word; 'COMPUTER'

Thus, total letter = 8

These letters can be rearranged in ways = $8! - 1 = 40319$

(As it is asking for rearrangement, thus subtract 1 from the arrangement)

Hence, option (b) is correct i.e., 40319.

15. (a) Given word; 'DICTIONARY'

Total letters = 10

Therefore, the number of four letter words can be formed is ${}^{10}P_4 = \frac{10!}{6!} = 5040$.

16. (b) Given, Number of persons = 5

Therefore, five persons can stand in a line for a group photography in ${}^5P_5 = 5! = 120$ ways

17. (a) Given, 5 different trophies need to be arranged

— — — — —

Since, one particular trophy must always be in the middle, thus the rest 4 trophies can be arranged in $4! \times 1$ ways = 24 ways.

18. (a) In the word 'MOBILE' there are total 3 odd and 3 even places.

Now, for the consonants to occupy the odd places, the possible arrangements are 3P_3 .

For the remaining three vowels the possible arrangements are 3P_3 .

Thus, total numbers of ways = ${}^3P_3 \times {}^3P_3$

$$= \frac{3!}{(3-3)!} \times \frac{3!}{(3-3)!}$$

$$= 3! \times 3! = 36$$

Hence, option (a) is correct i.e., 36.

19. (a) Given; Number of speaker = 5 (A, B, C, D and E)

Now, C, D and E can arrange themselves in $3!$ ways.

Since, A will speak always before B thus the number of ways they can arrange is 1 way.

Thus, the four units i.e., [(A, B), C, D and E] can arrange themselves in $4!$ ways.

Therefore, the total ways = $4! \times 1 = 24$

20. (c) Given; "PETROL"

Since, the words do not have "P" in the first position thus the first position can be filled in 5 ways.

Therefore, the remaining positions can be filled in $5 \times 4 \times 3 \times 2 \times 1$ ways.

Hence, the total ways = $5 \times 5 \times 4 \times 3 \times 2 \times 1 = 600$

21. (c) Given; Total persons = 8

Since, the President and the Vice-President be occupying middle places thus the required ways they can be seated is $2!$.

Now, remaining persons = 6

Thus, the remaining persons can be seated in $6!$ ways.

Therefore, the total ways = $2! \times 6!$

22. (c) Given; 5 Doctors, 4 Professors and 6 Auditors be seated in a row

Since, all person of the same profession sit together i.e.,

Number of ways Doctors can be seated = $5!$

Number of ways Professors can be seated = $4!$

Number of ways Auditors can be seated = $6!$

Since, these all three can also interchange their seats which can be done in $3!$ ways.

Therefore, the total required ways = $3! \times 5! \times 4! \times 6!$

23. (a) Given word; 'LOGARITHMS'

Thus, total letters = 10

Therefore, the required ways = ${}^{10}P_4$

$$= \frac{10!}{(10-4)!} = \frac{10!}{6!}$$

$$= 10 \times 9 \times 8 \times 7 = 5040$$

24. (b) Given word 'MATHEMATICS'

Total letters: 11

Vowels: A, A, E, I

Consonants: M, T, H, M, T, C, S

Since, the vowels always occur together thus the total ways

$$\frac{8!}{2! \times 2!} \times \frac{4!}{2!} = \frac{8! \times 4!}{(2!)^3}$$

25. (a) Given word; FAILURE

Total letters = 7

Here, Vowels = A, I, U and E

Consonants: F, L and R

— — — — —
Since, the consonants may occupy the odd positions only i.e., 1, 3, 5 and 7

Thus, the number of ways of arranging consonants = 4P_3

Therefore, the remaining letters can be arranged in $4!$ ways.

Hence, the total ways = ${}^4P_3 \times 4! = 576$ ways

26. (d) Given word; 'CORPORATION'

Total words = 11

Vowels (O, O, A, I, O) = 5

Consonants (C, R, P, R, T, N) = 6

Since, the vowels should always come together i.e., considering them as one unit

Now, 6 consonants and vowels (one unit) can be arranged in $\frac{7!}{2!}$ ways (Since, R is repeating twice).

Also, 5 vowels can arrange themselves in $\frac{5!}{3!}$ ways (Since, O is repeating thrice).

$$\begin{aligned} \text{Therefore, the total ways} &= \frac{7!}{2!} \times \frac{5!}{3!} \\ &= \frac{5040}{2} \times \frac{120}{6} = 50400 \end{aligned}$$

27. (a) As we know, 4 Americans can be seated at a round table in $(4-1)! = 3!$ ways.

Also, there are 4 spaces between two Americans so 4 English men can be seated in $4!$ ways.

Thus, the possible number of arrangements = $3! \times 4!$

Hence, option (a) is correct i.e., $4! \times 3!$

28. (a) Assume the tallest and shortest person as one.

Now, we have total 4 persons.

We know that,

Number of circular permutation of n different things chosen at a time = $(n-1)!$

Therefore, the number of such arrangements is $(4-1)! = 3! = 6$

Hence, option (a) is correct i.e., 6.

29. (c) Since, no two women are adjacent thus between every pair of men there should be a woman seated.

The number of ways the men can sit in a circular table is given as,

$$= (4-1)! = 3! = 6$$

Now, 4 vacant seats occupied by women can be arranged in

$${}^4P_4 = \frac{4!}{0!} = 24$$

Thus, the desired number of ways = $24 \times 6 = 144$

Hence, the correct option is (c).

30. (a) According to the question,

The word FAILURE (4 vowels and 3 consonants)

Number of odd places = 4, Number of even places = 3

Number of ways to arrange 3 consonants in 4 places,

$$= {}^4P_3 = \frac{4!}{1!} = 24$$

Now, vowels can be arranged in $4!$ ways, thus the total number of arrangements

$$= 24 \times 4!$$

$$= 24 \times 24 = 576$$

Hence, the correct answer is option (a).

31. (a) Number of ways in which ' n ' things can be arranged is $n!$ ways.

We will have only $(n - 1)$ articles, when we take two article together.

Now, these articles can be arranged in $(n - 1)!$

So, the number of ways so that two particular articles never come together

= Total ways - Number of ways when two particular articles come together

$$= n! - 2! \times (n - 1)!$$

$$= n(n - 1)! - 2(n - 1)!$$

$$= (n - 1)! \times (n - 2)$$

Hence, option (a) is correct

32. (c) Given; ${}^{15}C_{3r} = {}^{15}C_{r+3}$,

We know,

$${}^nC_x = {}^nC_y$$

$$\Rightarrow n = x + y \text{ or } x = y$$

$$\Rightarrow 15 = 3r + r + 3$$

$$\Rightarrow 4r = 12$$

$$\Rightarrow r = 3$$

'or'

$$3r = r + 3$$

$$\Rightarrow 2r = 3$$

$$\Rightarrow r = \frac{3}{2} \text{ (Reject)}$$

Since, r cannot be in fraction.

Therefore, the value of r is 3.

33. (b) Given, ${}^{20}C_r = {}^{20}C_{r+6}$

We know,

If ${}^nC_x = {}^nC_y$, then either $x = y$ or $x + y = n$

$$\text{Thus, } r + (r + 6) = 20$$

$$\Rightarrow 2r + 6 = 20$$

$$\Rightarrow 2r = 14$$

$$\Rightarrow r = 7$$

34. (b) Given, Number of boys = 7

Number of girls = 4

Number of teams with at least one girl = Total number of teams - Number of teams with no girls

$${}^{11}C_5 - {}^7C_5$$

$$= \frac{11!}{6! \times 5!} - \frac{7!}{2! \times 5!}$$

$$= 462 - 21 = 441$$

35. (a) Given; Total member = 11

Number of males = 5

Number of females = 6

Therefore, the number of ways of picking 2 males and 3 females from the given team is given by;

$${}^5C_2 \times {}^6C_3$$

$$= \frac{5!}{3! \times 2!} \times \frac{6!}{3! \times 3!}$$

$$= \frac{5 \times 4}{2} \times \frac{6 \times 5 \times 4}{3 \times 2} = 200$$

36. (a) No. of guests = 40

As we know for the shake hands, 2 persons are required.

Thus, total number of hand shakes = ${}^{40}C_2$

$$= \frac{40!}{(40 - 2)! \times 2!}$$

$$= \frac{40!}{38! \times 2!} = \frac{40 \times 39}{2} = 780$$

37. (b) Given, Number of apples = 7

Number of bananas = 6

Number of mangoes = 4

Thus, selections of 3 fruits such that all 3 are apples are done in 7C_3 ways

$$= \frac{7!}{(7 - 3)! \times 3!}$$

$$= \frac{7 \times 6 \times 5}{3!} = 35$$

38. (c) Given; 3 engineers, 2 psychologists and 3 managers

Total members = 8

Since, interview panel of 3 members is to be formed where at least 1 engineer must be included thus

Required ways = Total ways - None of them is engineer

$$= {}^8C_3 - {}^8C_3$$

$$= 56 - 10 = 46$$

Hence, the required ways = 46.

39. (c) We have 3 ladies and 3 gents.

We can select 2 ladies out of 3 in ${}^3C_2 = 3$ ways.

Only two ladies sit together means remaining can't sit adjacent to selected, which leaves us with the option that selected ladies are surrounded by gents.

Chosen two ladies can sit together in $2!$ ways.

Now, 4 seats remains and remaining lady can't took the adjacent one, which leaves 2 ways for her.

Gents can be arranged in $3!$ ways on the remaining seats.

Thus, total number of ways = $3 \times 2! \times 2 \times 3! = 72$

Hence, option (c) is correct.

40. (c) Given, Total points = 20

No. of collinear points = 5

We know that, 3 points are required to form a triangle for which atleast 2 points should be non-collinear.

Thus, the required triangles = ${}^{20}C_3 - {}^5C_3$

$$= \frac{20!}{3! \times 17!} - \frac{5!}{3! \times 2!}$$

$$= \frac{20 \times 19 \times 18}{3 \times 2} - \frac{5 \times 4}{2 \times 1}$$

$$= 1140 - 10 = 1130$$

Therefore, 1130 triangles can be formed using the given points.

Hence, the correct option is (c).

41. (b) Given; Number of women = 5 and Number of men = 3

Since, a committee of 3 members is to be formed where at least 2 members should be women thus the possible ways; 2 women & 1 Men) or (3 Women)

$$\Rightarrow {}^5C_2 \times {}^3C_1 + {}^5C_3$$

$$\Rightarrow 10 \times 3 + 10$$

$$\Rightarrow 30 + 10 = 40$$

42. (a) As we know, a triangle can be formed by 3 non - collinear points. So, total number of ways of selecting 3 points will be given as,

$$= {}^{12}C_3 \left[\therefore {}^nC_r = \frac{n!}{r! \times (n-r)!} \right]$$

But, 7 points lie on straight line, thus the number of selections = 7C_3

Therefore, required number of triangles will be given as,

$$= {}^{12}C_3 - {}^7C_3$$

$$= \frac{12!}{3! \times 9!} - \frac{7!}{3! \times 4!} = 185$$

Hence, the correct option is (a) i.e., 185.

43. (c) Given; Total number of point = 6 + 5 = 11

Here, Six points are marked on a straight line and five points are marked on another line which is parallel to the first line i.e.,

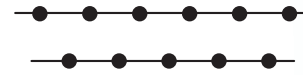

Therefore, the total straight line that can be formed is given by;

$${}^{11}C_2 - {}^6C_2 - {}^5C_2 + 2$$

$$= \frac{11!}{9! \times 2!} - \frac{6!}{4! \times 2!} - \frac{5!}{3! \times 2!} + 2$$

$$= 55 - 15 - 10 + 2 = 32$$

44. (a) Given; Total questions = 10

Number of questions of Algebra = 6 & Number of questions of Geometry = 4

Since, At least one question from each section is to be attempted thus Number of ways of attempting questions from Algebra is given by;

$$= {}^6C_1 + {}^6C_2 + {}^6C_3 + {}^6C_4 + {}^6C_5 = 2^6 - 1 = 63$$

Similarly, Number of ways of attempting questions from Geometry is given by;

$$2^4 - 1 = 15$$

Therefore, the total ways = $63 \times 15 = 945$.

45. (a) In the word 'EXAMINATION',

Total letters = 11

Number of 'A' = 2

Number of 'I' = 2

Number of 'N' = 2

Thus, we have E, X, M, T, O, (AA), (II), (NN) i.e., 8 distinct letters.

Case I: When all are distinct, then the number of ways:

$${}^8C_4 \text{ ways} = 70 \text{ ways}$$

Case II: 2 letters alike and 2 distinct (e.g: MTNN, EOII etc), then the number of ways:

$${}^3C_1 \times {}^7C_2 \text{ ways} = 63 \text{ ways}$$

Case III: 2 letters alike and 2 letters alike (e.g: IINN, IAIA etc), then the number of ways;

$${}^3C_2 \text{ ways} = 3 \text{ ways}$$

Total way of selecting 4 letters of the word 'EXAMINATION' = $70 + 63 + 3 = 136$

Hence, option (a) is correct.

Chapter Wrap-up Test

Ready to test your knowledge?

You've got 15 questions and 20 minutes - go for it!

1. ${}^6P_r = 30$, then the value of r is
 (a) 3 (b) 2 (c) 4 (d) 1
2. If ${}^nC_{10} = {}^nC_{14}$, then the value of ${}^{25}C_n$ is
 (a) 24 (b) 25
 (c) 1 (d) None of these
3. How many necklaces can be formed with 6 beads of different colours?
 (a) 360 (b) 120 (c) 60 (d) 720
4. The number ways in which 4 persons can occupy 9 vacant seats is
 (a) 6048 (b) 3024
 (c) 1512 (d) 4536
5. Find the number of arrangements of 7 items out of 10 when one particular items never occurs.
 (a) 720 (b) 72 (c) 504 (d) None
6. Out of 6 boys & 4 girls, find the number of ways for selecting 5 members for a committee in which there are exactly two girls?
 (a) 120 (b) 1440
 (c) 720 (d) 71
7. How many different arrangements can be made beginning with 'N' and ending in 'A' with the letters of the word 'ORIENTAL'?
 (a) 6! (b) 8! (c) 4! (d) None
8. Out of 10 consonants and 4 vowels, how words can be formed each containing 6 consonants and 3 vowels?
 (a) ${}^{10}C_6 \times {}^4C_3$
 (b) ${}^{10}C_6 \times {}^4C_3 \times 9!$
 (c) ${}^{10}C_6 \times {}^4C_3 \times 10!$
 (d) None
9. In an election, there are five candidates contesting for three vacancies; an elector can vote any number of candidates not exceeding the number of vacancies. In how many ways can one cast his votes?
 (a) 10 (b) 25 (c) 30 (d) 50
10. The number of parallelogram that can be formed by a set of 6 parallel lines intersected by the another set of 4 parallel lines is _____.
 (a) 360 (b) 90 (c) 180 (d) 45
11. In how many ways of the word 'MATHEMATICS' be arranged so that the vowels always occur together?
 (a) $11! \times (2!)^3$ (b) $\frac{8! \times 4!}{(2)^3}$
 (c) $\frac{12!}{(2)^3}$ (d) None of these
12. If ${}^nP_4 = 12 \times {}^nP_2$, then n is equal to
 (a) -1 (b) 6
 (c) 5 (d) None of these
13. Five bulbs of which three are defective are to be tried in two light-points in a dark room. In how many trails the room shall be lighted?
 (a) 10 (b) 7
 (c) 3 (d) None of these
14. There are 20 points in a plane area. How many triangles can be formed by these points if 5 points are collinear?
 (a) 550 (b) 560 (c) 1130 (d) 1140
15. If $\frac{(2n)!}{3!(2n-3)!} : \frac{n!}{2!(n-2)!} = 44 : 3$, then the value of n is
 (a) 2 (b) 5 (c) 6 (d) 12

ANSWER KEY

1. (b) 2. (b) 3. (c) 4. (b) 5. (b) 6. (a) 7. (a) 8. (b) 9. (b) 10. (b)
 11. (b) 12. (b) 13. (b) 14. (c) 15. (c)





Sequence and Series-Arithmetic and Geometric Progressions

Cheat Sheet by Anurag Sir

Arithmetic Progression (A.P)

- nth term of an arithmetic progression:
 $t_n = a + (n - 1)d$

Where, a = first term, d = common difference and n = position of the required term.

- Sum of n terms of an arithmetic progression:

$$S_n = \frac{n}{2} [2a + (n - 1)d]$$

$$S_n = \frac{n(a + l)}{2} \text{ where, } a = \text{first term, } l = \text{last and } d = \text{common difference}$$

- If m th term of an A.P is p and n th term is q then,

$$\text{Common difference} = \frac{p - q}{m - n}$$

- If m th term of an A.P is p and n th term is q then r th term is

$$a_r = p + (r - m)d$$

Geometric Progression (G.P)

- nth term of a geometric progression:

$$t_n = ar^{n-1}, \text{ where, } a = \text{first term, } r = \text{common ratio}$$

- Sum of n terms of a geometric progression:

$$\text{If common ratio, } r > 1, \text{ then } S_n = \frac{a(r^n - 1)}{r - 1}$$

- If common ratio, $r < 1$, then

$$S_n = \frac{a(1 - r^n)}{1 - r}$$

- Sum of Infinite Geometric Series:

$$S_n = \frac{a}{1 - r}, r < 1$$

- Arithmetic Mean (A): $A = \frac{a + b}{2}$

- Geometric Mean (G): $G = \sqrt{ab}$

- Sum of 1st n natural or counting numbers: 1, 2, 3, 4, 5, 6, 7,....., n

$$S = \left(\frac{n(n + 1)}{2} \right)$$

- Sum of the squares of the first, n natural number:

$$S = 1^2 + 2^2 + 3^2 + \dots + n^2 = \frac{n(n + 1)(2n + 1)}{6}$$

- Sum of Cubes of the first, n natural number:

$$S = 1^3 + 2^3 + 3^3 + \dots + n^3 = \left\{ \frac{n(n + 1)}{2} \right\}^2$$

Selection of terms of an Arithmetic Progression

When sum of terms of an A.P. is given

Number of Terms	Terms	Common Difference
3	$a - d, a, a + d$	d
4	$a - 3d, a - d, a + d, a + 3d$	$2d$
5	$a - 2d, a - d, a, a + d, a + 2d$	d
6	$a - 5d, a - 3d, a - d, a + d, a + 3d, a + 5d$	$2d$
7	$a - 3d, a - 2d, a - d, a, a + d, a + 2d, a + 3d$	d

Selection of terms of a Geometric Progression

When the product of terms of G.P. is given

Number of Terms	Terms	Common Ratio
3	$\frac{a}{r}, a, ar$	r
4	$\frac{a}{r^3}, \frac{a}{r}, ar, ar^3$	r^2
5	$\frac{a}{r^2}, \frac{a}{r}, a, ar, ar^2$	r
6	$\frac{a}{r^5}, \frac{a}{r^3}, \frac{a}{r}, ar, ar^3, ar^5$	r^2
7	$\frac{a}{r^3}, \frac{a}{r}, a, ar, ar^2, ar^3$	r

QUESTIONS

- Find the 9th term of the A.P: 8, 5, 2, -1, -4,.....
[PYQ-Jan., 2025]
(a) -24 (b) -10
(c) -16 (d) -4
- In an arithmetic progression (A.P.), the seventh term is x , and the $(x + 7)^{\text{th}}$ term is 0. Then, what is the x^{th} term?
[PYQ-June 2024]
(a) 6 (b) 7
(c) 8 (d) 10
- If the fourth term of an Arithmetic Progression (A.P.) series is zero, then what is the ratio of the twenty-fifth term to the eleventh term?
[PYQ-Sept., 2024]
(a) 4 (b) 5
(c) 3 (d) 2
- The 3rd term of arithmetic progression is 7 and Seventh term is 2 more than thrice of third term. The common difference is [PYQ-June., 2024]
(a) 4 (b) 3
(c) 5 (d) 6
- If 9th and 19th term of an Arithmetic Progression are 35 and 75 respectively, then its 20th term is [PYQ-Dec., 2023]
(a) na (b) $\frac{a}{n}$
(c) $2n + n(a - 1)$ (d) $n + a(n - 1)$
- The sum of the series $1 + 2 + 3 + \dots$ is 55. The number of terms is: [PYQ-Jan., 2025]
(a) 30 (b) 40
(c) 20 (d) 10
- The sum of 4th and 8th term of an AP is 10, then the sum of first eleven terms of the series is [PYQ-Jan., 2025]
(a) 22 (b) 33
(c) 44 (d) 55
- The first and the last term of an AP are -4 and 146 respectively. The sum of the terms is 7171. The number of terms is [MTP-Jan., 2025]
(a) 101 (b) 100
(c) 99 (d) None of these
- If the second and eighth terms of an arithmetic progression (A.P.) are equal to a constant a , then the sum of the first n terms of this A.P. is: [PYQ-June, 2024]

10. If the n th term of an A.P. is $7n - 2$. Then the sum of ' n ' terms is **[PYQ-Dec., 2023]**

- (a) $0.5(7n^2 + 2n)$
 (b) $0.5(7n^2 - 3n)$
 (c) $0.5(7n^2 + 3n)$
 (d) $0.5(7n^2 - 2n)$

11. Find the sum of n terms of the A.P, whose n th term is $5n + 1$. **[PYQ-May, 2025]**

- (a) $\frac{n}{2}$ (b) $\frac{2n}{7}$
 (c) $\frac{n(7+5n)}{2}$ (d) $\frac{n(7n+4n)}{2}$

12. Find the 17th term of an AP series if 15th and 21st terms are 30.5 and 39.5 respectively. **[PYQ-Dec., 2023]**

- (a) 33.5 (b) 35.5
 (c) 36.0 (d) 38.0

13. Find the value of ' x ' for the following data $1 + 7 + 13 + 19 + \dots + x = 225$. **[PYQ-Dec., 2023]**

- (a) 56 (b) 63
 (c) 49 (d) 42

14. The 4 arithmetic means between -2 and 23 are **[MTP-May, 2025]**

- (a) 3, 13, 8, 18
 (b) 18, 3, 8, 13
 (c) 3, 8, 13, 18
 (d) None of these

15. Insert 4 numbers between 2 and 22 such that the resulting sequence is an Arithmetic Progression (A.P.). **[PYQ-May, 2025]**

- (a) 4, 8, 12, 16 (b) 5, 9, 13, 17
 (c) 4, 10, 15, 19 (d) 6, 10, 14, 18

16. A roadside tea stall merchant borrows ₹9,000 at 2.76% simple interest per annum. The principal and interest are to be paid in 10 monthly instalments, where each instalment is double the preceding one. Find the value of the last instalment. **[PYQ-Sept., 2024]**

- (a) ₹4,608 (b) ₹1,024
 (c) ₹9,207 (d) ₹4,096

Geometric Progression

17. The 7th term of the series 6, 12, 24..... n th term is _____. **[PYQ-May, 2025]**

- (a) 384 (b) 834
 (c) 438 (d) 854

18. The last term of the series $x^2, x, 1, \dots$ to 31 terms is **[MTP-May, 2025]**

- (a) x^{28} (b) $\frac{1}{x}$
 (c) $\frac{1}{x^{28}}$ (d) $\frac{1}{x^{30}}$

19. In a G.P. 5th term is 27 and 8th term is 729. Find its 11th term **[PYQ-Dec., 2022]**

- (a) 729 (b) 6561
 (c) 2187 (d) 19683

20. If 4th, 7th and 10th terms of a Geometric Progression are p, q and r respectively, then; **[PYQ-Dec., 2023]**

- (a) $p^2 = q^2 + r^2$ (b) $p^2 = qr$
 (c) $q^2 = pr$ (d) $pqr + pq + 1 = 0$

21. Find the sum of the series:

$$1 + \frac{1}{2} + \frac{1}{4} + \frac{1}{8} + \dots \text{ up to 6 terms}$$

[PYQ-May, 2025]

- (a) $\frac{63}{32}$ (b) $\frac{32}{63}$
 (c) $\frac{26}{53}$ (d) $\frac{53}{26}$

22. The sum upto infinity of the series;

$$\frac{1}{2} + \frac{1}{6} + \frac{1}{18} + \dots \text{ is}$$

[PYQ-June, 2023]

- (a) $\frac{5}{4}$ (b) $\frac{3}{4}$
 (c) $\frac{7}{3}$ (d) None of these

23. The sum of the series $\frac{1}{2} + \frac{1}{3^2} + \frac{1}{2^3} + \frac{1}{3^4} + \dots$ up to infinity is **[PYQ-Dec., 2019]**

- (a) $\frac{25}{24}$ (b) $\frac{19}{24}$
 (c) $\frac{1}{12}$ (d) None of these

24. The 3rd term of a G.P. is $\frac{2}{3}$ and 6th term is $\frac{2}{81}$, then the first term is **[PYQ-Sept., 2024]**

- (a) 6 (b) $\frac{1}{3}$
(c) 9 (d) 2

25. If for an infinite geometric progression, first term is 'a' common ratio is 'r', the sum is 8 and the second term is $\frac{7}{8}$, then **[PYQ-Sept., 2024]**

- (a) $a=4, r=\frac{7}{16}$ (b) $a=3, r=\frac{7}{24}$
(c) $a=7, r=\frac{1}{8}$ (d) $a=2, r=\frac{7}{32}$

26. The sum of 3 numbers of a G.P. is 39 and their product is 729. The numbers are- **[PYQ-May, 2025]**

- (a) 3, 27, 9
(b) 9, 3, 27
(c) 3, 9, 27
(d) None of these

27. The product of three numbers which are in GP is 512. Then the second number is: **[PYQ-Jan., 2025]**

- (a) 3 (b) 2
(c) 6 (d) 8

28. Given an infinite geometric series with first term 'a' and common ratio 'r'. If its sum is 4 and the second term is $\frac{3}{4}$, then one of the correct option is **[PYQ-Dec., 2023]**

- (a) $a=1, r=\frac{1}{4}$ (b) $a=3, r=\frac{3}{4}$
(c) $a=3, r=\frac{1}{4}$ (d) $a=1, r=\frac{1}{2}$

29. The sum of the first three terms of a G.P. is $\frac{21}{2}$, and their product is 27. Which of the following is not a term of the G.P., if the numbers are positive? **[PYQ-May, 2025]**

- (a) 3 (b) $\frac{2}{3}$
(c) $\frac{3}{2}$ (d) 6

30. The sum of three numbers in G.P is 70. If the two extremes multiplied each by 4 and the mean by 5, the product are in A.P. The numbers are **[MTP-Jan., 2025]**

- (a) 12, 18, 40 (b) 10, 20, 40
(c) 40, 20, 15 (d) None of these

31. The numbers x, 8, y in Geometric Progression (G.P) and the numbers x, y, -8 are in Arithmetic Progression (A.P). Find the values of x and y respectively. **[PYQ-Sept., 2024]**

- (a) 4, 16 (b) 16, 4
(c) 4, 8 (d) 8, 4

32. If the A.M. and G.M. for two numbers are 6.50 and 6 respectively then the two numbers are **[PYQ-May, 2025]**

- (a) 6 and 7 (b) 9 and 4
(c) 10 and 3 (d) 8 and 5

ANSWER KEY

1. (c) 2. (b) 3. (c) 4. (a) 5. (b) 6. (d) 7. (d) 8. (a) 9. (a) 10. (c)
11. (c) 12. (a) 13. (c) 14. (c) 15. (d) 16. (b) 17. (a) 18. (c) 19. (d) 20. (b)
21. (a) 22. (b) 23. (b) 24. (a) 25. (c) 26. (c) 27. (d) 28. (c) 29. (b) 30. (b)
31. (a) 32. (b)

HINTS & SOLUTIONS

1. (c) Given A.P: 8, 5, 2, -1, -4,

Here, $a = 8$, $d = 5 - 8 = -3$

Thus, 9th term is given by

$$t_9 = a + (9 - 1)d$$

$$t_9 = 8 + 8(-3)$$

$$t_9 = 8 - 24$$

$$t_9 = -16$$

2. (b) Let;

First term = a

Common difference = d

Given;

$$t_7 = a + 6d = x \quad \text{.....(1)}$$

$$t_{x+7} = a + (x + 6)d = 0 \quad \text{.....(2)}$$

or,

$$a = x - 6d \quad \text{[From Equ., (1)]}$$

$$t_{x+7} = (x - 6d) + (x + 6)d = 0$$

Thus,

$$x - 6d + xd + 6d = 0$$

$$\Rightarrow x + xd = 0$$

$$\Rightarrow d = -1$$

$$\text{Now, } a = x - 6d = x - 6(-1) = x + 6$$

Therefore, the x^{th} term is given by;

$$t_x = a + (x - 1)d$$

$$= (x + 6) + (x - 1)(-1)$$

$$= x + 6 - x + 1 = 7$$

Hence, the x^{th} term is 7.

3. (c) Let the first term be a and the common difference be d .

The n^{th} term of an A.P. is:

$$t_n = a + (n - 1)d$$

Since, the 4th term is zero thus

$$t_4 = a + 3d = 0$$

$$a = -3d$$

Now, the 25th and 11th terms is given by;

$$t_{25} = a + 24d$$

$$t_{11} = a + 10d$$

Substitute $a = -3d$ into these terms:

$$t_{25} = -3d + 24d = 21d$$

$$t_{11} = -3d + 10d = 7d$$

Therefore, the required ratio is given by;

$$\frac{t_{25}}{t_{11}} = \frac{21d}{7d} = 3$$

4. (a) Let the first term be a , and common difference be d ,

$$\text{Third term; } t_3 = a + 2d = 7 \quad \text{.....(1)}$$

$$\text{Seventh term; } t_7 = a + 6d \quad \text{.....(2)}$$

Given,

$$t_7 = 3 \times t_3 + 2 = 3 \times 7 + 2 = 21 + 2 = 23$$

From eq., (1)

$$a = 7 - 2d$$

Substitute into (2);

$$t_7 = a + 6d = (7 - 2d) + 6d = 7 + 4d$$

$$\text{i.e., } 7 + 4d = 23$$

$$\Rightarrow 4d = 16$$

$$\Rightarrow d = 4$$

5. (b) Given; 9th and 19th term of an Arithmetic Progression are 35 and 75 respectively i.e.,

$$a_9 = 35 \text{ \& } a_{19} = 75$$

Here, common difference is given by;

$$d = \frac{a_{19} - a_9}{19 - 9}$$

$$\Rightarrow d = 4$$

Therefore, 20th term is given by;

$$a_{20} = a_{19} + d$$

$$\Rightarrow a_{20} = 75 + 4$$

$$\Rightarrow a_{20} = 79$$

6. (d) Given Series; $1 + 2 + 3 + \dots$

The sum of the first n natural numbers is;

$$S_n = \frac{n}{2}(n+1)$$

Given;

$$55 = \frac{n}{2}(n+1)$$

$$110 = n(n+1)$$

$$n^2 + n - 110 = 0$$

$$n = \frac{-1 \pm \sqrt{1 + 440}}{2} = \frac{-1 \pm 21}{2}$$

$$n = \frac{20}{2} = 10$$

(Since, n cannot be negative)

Therefore, the number of terms is 10.

7. (d) Given; sum of 4th and 8th term of an AP = 10

i.e.,

$$t_4 + t_8 = 10$$

$$\Rightarrow (a + 3d) + (a + 7d) = 10$$

$$\Rightarrow 2a + 10d = 10 \quad \dots\dots(1)$$

Now, sum of first eleven terms of the A.P is given by

$$S_{11} = \frac{11}{2}[2a + (11-1)d]$$

$$= \frac{11}{2}[2a + 10d]$$

$$= \frac{11}{2} \times 10 = 55$$

8. (a) We know that, Sum of first n terms of an A.P. is given by,

$$S_n = \frac{n}{2}[a + l]$$

where, a = first term and l = last term

Given that,

$$a = -4$$

$$l = 146$$

$$S_n = 7171$$

Now, substituting the given values

$$\Rightarrow 7171 = \frac{n}{2}[-4 + 146]$$

$$\Rightarrow 7171 = \frac{n(142)}{2}$$

$$\therefore n = 101$$

Therefore, the correct option is (a) i.e., 101.

9. (a) Let,

First term = A

Common difference = d

Then,

Second term = $A + d = a$

Eighth term = $A + 7d = a$

One equating the above equations, we get

$$A + 7d = A + d$$

$$\Rightarrow 7d = d$$

$$\Rightarrow 6d = 0$$

$$\Rightarrow d = 0$$

i.e., $A + d = a$

$$\Rightarrow A = a$$

So, the A.P. becomes;

$a, a, a, a, \dots\dots$

All terms are equal to a , and the common difference is 0.

So, sum of first n term is; $S_n = n \cdot a$

10. (c) According to question, we have

n th term of A.P (a_n) = $7n - 2$

$$\Rightarrow a_1 = 7(1) - 2 = 5$$

$$\Rightarrow a_2 = 7(2) - 2 = 12$$

$$\Rightarrow a_3 = 7(3) - 2 = 19$$

$$\text{Thus, } d = 12 - 5 = 7$$

Therefore, the sum of ' n ' terms is given by;

$$S_n = \frac{n}{2}[2a + (n-1)d]$$

$$\Rightarrow S_n = \frac{n}{2}[2(5) + (n-1)7]$$

$$\Rightarrow S_n = \frac{n}{2}[10 + 7n - 7]$$

$$\Rightarrow S_n = \frac{n}{2}[3 + 7n]$$

$$\Rightarrow S_n = 0.5(7n^2 + 3n)$$

11. (c) The n th term is given by;

$$t_n = 5n + 1$$

The first term, $a = t_1 = 5(1) + 1 = 6$

The second term, $t_2 = 5(2) + 1 = 11$

Common difference $d = t_2 - t_1 = 11 - 6 = 5$

Sum of first n terms of an A.P. is;

$$S_n = \frac{n}{2}[2a + (n-1)d]$$

Substitute $a = 6$ and $d = 5$

$$S_n = \frac{n}{2}[2 \times 6 + (n-1) \times 5]$$

$$= \frac{n}{2}[12 + 5n - 5]$$

$$= \frac{n}{2}(7 + 5n)$$

12. (a) According to question, we have

$$t_{15} = 30.5 \text{ and } t_{21} = 39.5$$

$$\Rightarrow a + 14d = 30.5 \text{ and } a + 20d = 39.5$$

On subtracting both the equations, we get

$$a + 20d - (a + 14d) = 39.5 - 30.5$$

$$\Rightarrow 20d - 14d = 9$$

$$\Rightarrow 6d = 9$$

$$\Rightarrow d = 1.5$$

$$\text{Now, } a = 30.5 - 14d = 30.5 - 14(1.5) = 9.5$$

Therefore, 17th term is given by;

$$t_{17} = a + 16d$$

$$\Rightarrow t_{17} = 9.5 + 16(1.5)$$

$$\Rightarrow t_{17} = 33.5$$

- 13.** (c) Given data; $1 + 7 + 13 + 19 + \dots x = 225$

Clearly, it is an A.P with $a = 1$ & $d = 6$.

We know that,

$$\text{Sum of } n \text{ terms of A.P} = \frac{n}{2}[2a + (n-1)d]$$

$$\Rightarrow 225 = \frac{n}{2}[2 \times 1 + (n-1) \times 6]$$

$$\Rightarrow 225 = \frac{n}{2} \times 2[1 + (n-1)3]$$

$$\Rightarrow n(1 + 3n - 3) = 225$$

$$\Rightarrow n(3n - 2) = 225$$

$$\Rightarrow 3n^2 - 2n - 225 = 0$$

$$\Rightarrow 3n^2 - 27n + 25n - 225 = 0$$

$$\Rightarrow 3n(n - 9) + 25(n - 9) = 0$$

$$\Rightarrow (3n + 25)(n - 9) = 0$$

$$\Rightarrow n = 9, n = -\frac{25}{3} \text{ (Reject)}$$

$$\Rightarrow n = 9$$

Also, sum of n terms is given by;

$$S_n = \frac{n}{2}(a + l)$$

$$\Rightarrow \frac{n}{2}(1 + x) = 225$$

$$\Rightarrow \frac{9}{2}(1 + x) = 225$$

$$\Rightarrow (1 + x) = 50$$

$$\Rightarrow x = 49$$

- 14.** (c) We are to insert 4 arithmetic means between -2 and 23.

So, the sequence will have 6 terms total:

$$-2, _, _, _, _, 23$$

This is an Arithmetic Progression (A.P.)

Let the common difference be d .

Let the sequence be:

$$-2, a_2, a_3, a_4, a_5, 23$$

The 6th term in an A.P. is:

$$a_6 = a_1 + 5d = -2 + 5d = 23$$

$$\Rightarrow 5d = 25$$

$$\Rightarrow d = 5$$

Now compute the term:

$$\Rightarrow a_1 = -2$$

$$\Rightarrow a_2 = -2 + 5 = 3$$

$$\Rightarrow a_3 = 3 + 5 = 8$$

$$\Rightarrow a_4 = 8 + 5 = 13$$

$$\Rightarrow a_5 = 13 + 5 = 18$$

$$\Rightarrow a_6 = 18 + 5 = 23$$

The four arithmetic means are: 3, 8, 13, 18

- 15.** (d) We are to insert 4 numbers between 2 and 22 \rightarrow total 6 terms in the A.P.

Let the 6 terms be:

$$2, a_2, a_3, a_4, a_5, \dots 22$$

Let the common difference be d . Then:

- First term, $a = 2$

- Sixth term, $a + 5d = 22$

$$2 + 5d = 22$$

$$\Rightarrow 5d = 20$$

$$\Rightarrow d = 4$$

Now compute the terms:

- $a_2 = 2 + d = 6$

- $a_3 = 2 + 2d = 10$

- $a_4 = 2 + 3d = 14$

- $a_5 = 2 + 4d = 18$

Therefore, the required numbers are 6, 10, 14, 18.

- 16.** (b) According to question, we have

- Principle $P = ₹9,000$

- Rate $R = 2.76\%$ per annum

- Time $T = 10$ months $= \frac{10}{12} = \frac{5}{6}$ years

Simple Interest (S.I.) is given by

$$SI = \frac{P \times R \times T}{100} = \frac{9000 \times 2.76 \times 5}{6 \times 100}$$

$$= \frac{9000 \times 13.8}{600} = \frac{124200}{600} = ₹207$$

$$\begin{aligned} \text{Total amount to be repaid} &= ₹9,000 + ₹207 \\ &= ₹9,207 \end{aligned}$$

Let the first instalment be ₹ x .

Each instalment is double the previous one \rightarrow geometric progression with:

- First term $a = x$

- Common ratio $r = 2$

- Number of terms $n = 10$

Sum of a G.P.

$$S_n = a \cdot \frac{r^n - 1}{r - 1}$$

$$9,207 = x \cdot \frac{2^{10} - 1}{2 - 1} = x \cdot (1024 - 1) = x \cdot 1023$$

$$x = \frac{9207}{1023} = 9$$

Therefore, the last instalment is given by:

$$\text{Last (10th) instalment} = x \cdot 2^9 = 9 \cdot 512 = ₹4,608$$

17. (a) The series is 6, 12, 24..... which is a Geometric Progression (G.P.) because each term is multiplied by the same ratio.

- First term, $a = 6$
- Common ratio, $r = \frac{12}{6} = 2$

The n th term of a G.P. is given by

$$t_n = a \times r^{n-1}$$

For the 7th term:

$$t_7 = 6 \times 2^{7-1} = 6 \times 2^6 = 6 \times 64 = 384$$

18. (c) The series is:

$$x^2, x, 1, \dots$$

This is a Geometric Progression (G.P.) with:

- First term $a = x^2$
- Common ratio $r = \frac{x}{x^2} = \frac{1}{x}$

Therefore, the 31st term is given by;

$$\begin{aligned} t_{31} &= x^2 \times \left(\frac{1}{x}\right)^{31-1} \\ &= x^2 \times \left(\frac{1}{x}\right)^{30} = x^2 \times x^{-30} = x^{2-30} = x^{-28} = \frac{1}{x^{28}} \end{aligned}$$

19. (d) Let the first term of G.P. be 'a' and common ratio 'r'.

According to question, we have

$$t_5 = ar^4 = 27 \quad \dots(1)$$

$$t_8 = ar^7 = 729 \quad \dots(2)$$

Dividing eq., (2) by eq., (1), we get

$$\frac{ar^7}{ar^4} = \frac{729}{27}$$

$$\Rightarrow r^3 = 27 \Rightarrow r^3 = 3^3 \Rightarrow r = 3$$

Put the value of 'r' in eq (1), we get

$$a(3)^4 = 27$$

$$\Rightarrow a = \frac{1}{3}$$

Therefore, the 11th term will be

$$ar^{10} = \frac{1}{3} \times 3^{10} = 19683$$

20. (b) According to question, we have

$$a_4 = ar^3 = p \quad \dots(1)$$

$$a_7 = ar^6 = q \quad \dots(2)$$

$$a_{10} = ar^9 = r \quad \dots(3)$$

Multiplying eq. (1) and eq (3), we get

$$(ar^3)(ar^9) = pr$$

$$\Rightarrow a^2 r^{12} = pr$$

$$\Rightarrow (ar^6)^2 = pr$$

$$\Rightarrow q^2 = pr$$

21. (a) Given series;

$$1 + \frac{1}{2} + \frac{1}{4} + \frac{1}{8} + \dots$$

This is a Geometric Progression (G.P.) where;

- First term $a = 1$
- Common ratio $r = \frac{1}{2}$
- Number of terms, $n = 6$

We know that,

$$S_n = a \cdot \frac{1 - r^n}{1 - r}$$

$$\begin{aligned} S_6 &= 1 \cdot \frac{1 - \left(\frac{1}{2}\right)^6}{1 - \frac{1}{2}} = \frac{1 - \frac{1}{64}}{\frac{1}{2}} = \frac{\frac{63}{64}}{\frac{1}{2}} \\ &= \frac{63}{64} \cdot \frac{2}{1} = \frac{126}{64} = \frac{63}{32} \end{aligned}$$

22. (b) Given series; $S = \frac{1}{2} + \frac{1}{6} + \frac{1}{18} + \dots$

$$\text{Here, } \frac{\frac{1}{6}}{\frac{1}{2}} = \frac{1}{3}, \quad \frac{\frac{1}{18}}{\frac{1}{6}} = \frac{1}{3}$$

Since, the common ratio is same, thus the series is in G.P.

Now, the sum upto infinity is given by

$$\begin{aligned} \frac{a}{1 - r} \\ &= \frac{\frac{1}{2}}{1 - \frac{1}{3}} = \frac{\frac{1}{2}}{\frac{2}{3}} = \frac{3}{4} \end{aligned}$$

23. (b) Given;

$$S = \frac{1}{2} + \frac{1}{3^2} + \frac{1}{2^3} + \frac{1}{3^4} + \dots \infty$$

$$\Rightarrow S = \left[\frac{1}{2} + \frac{1}{2^3} + \frac{1}{2^5} + \dots \right] + \left[\frac{1}{3^2} + \frac{1}{3^4} + \frac{1}{3^6} + \dots \right]$$

$$\Rightarrow S = \frac{\frac{1}{2}}{1 - \frac{1}{2^2}} + \frac{\frac{1}{9}}{1 - \frac{1}{3^2}}$$

$$\Rightarrow S = \frac{\frac{1}{2}}{\frac{3}{4}} + \frac{\frac{1}{9}}{\frac{8}{9}}$$

$$\Rightarrow S = \frac{2}{3} + \frac{1}{8}$$

$$\Rightarrow S = \frac{19}{24}$$

24. (a) Given, 3rd term of a G.P. = $\frac{2}{3}$

$$\text{i.e., } ar^2 = \frac{2}{3} \quad \dots(1)$$

$$\text{Also, 6th term} = \frac{2}{81}$$

$$\text{i.e., } ar^5 = \frac{2}{81} \quad \dots(2)$$

Dividing (2) by (1), we get

$$\frac{ar^5}{ar^2} = \frac{\frac{2}{81}}{\frac{2}{3}}$$

$$\Rightarrow r^3 = \frac{1}{27}$$

$$\Rightarrow r = \frac{1}{3}$$

Therefore,

$$ar^2 = \frac{2}{3} \Rightarrow a \left(\frac{1}{3} \right)^2 = \frac{2}{3}$$

$$\Rightarrow \frac{a}{9} = \frac{2}{3}$$

$$\Rightarrow a = 6$$

25. (c) We know that,

Sum of infinite G.P is given by

$$S = \frac{a}{1-r}$$

Given;

$$\frac{a}{1-r} = 8 \quad \dots(1)$$

Also given;

$$\text{Second term} = ar = \frac{7}{8} \quad \dots(2)$$

From (1),

$$a = 8(1-r)$$

Substitute (3) into (2)

$$ar = [8(1-r)] \cdot r = \frac{7}{8}$$

$$\Rightarrow 8r(1-r) = \frac{7}{8}$$

$$\Rightarrow 64r(1-r) = 7$$

$$\Rightarrow 64r - 64r^2 = 7$$

$$\Rightarrow 64r^2 - 64r + 7 = 0$$

Using the quadratic formula:

$$r = \frac{-(-64) \pm \sqrt{(-64)^2 - 4 \times 64 \times 7}}{2 \times 64}$$

$$= \frac{64 \pm \sqrt{4096 - 1792}}{128}$$

$$r = \frac{64 \pm 48}{128}$$

$$1. r = \frac{64+48}{128} = \frac{112}{128} = \frac{7}{8}$$

$$2. r = \frac{64-48}{128} = \frac{16}{128} = \frac{1}{8}$$

Since,

$$ar = \frac{7}{8}$$

$$\text{Thus, for } r = \frac{1}{8}$$

$$a \left(\frac{7}{8} \right) = \frac{7}{8} \Rightarrow a = 1$$

$$\text{For, } r = \frac{1}{8}$$

$$a \left(\frac{1}{8} \right) = \frac{7}{8} \Rightarrow a = 7$$

Out of the given option, option (c) is correct.

26. (c) Let the three numbers of Geometric Progression be;

$$\frac{a}{r}, a, ar$$

According to question, we have

$$\frac{a}{r} + a + ar = 39$$

$$a + ar + ar^2 = 39r \Rightarrow a(1 + r + r^2) = 39r$$

Also, product of numbers is given by

$$\left(\frac{a}{r}\right) \cdot a \cdot ar = a^3 = 729$$

$$\Rightarrow a = \sqrt[3]{729} = 9$$

Substitute the value of a in above equation, we get

$$9(1 + r + r^2) = 39r$$

$$3(1 + r + r^2) = 13r$$

$$3 + 3r + 3r^2 = 13r$$

$$\Rightarrow 3r^2 - 10r + 3 = 0$$

Use quadratic formula:

$$r = \frac{10 \pm \sqrt{(-10)^2 - 4 \cdot 3 \cdot 3}}{2 \cdot 3} = \frac{10 \pm \sqrt{100 - 36}}{6}$$

$$\frac{10 \pm \sqrt{64}}{6} = \frac{10 \pm 8}{6}$$

So,

$$\bullet r = \frac{18}{6} = 3$$

$$\bullet r = \frac{2}{6} = \frac{1}{3}$$

Case-1; $r = 3, a = 9$

Numbers;

$$\frac{a}{r} = \frac{9}{3} = 3, a = 9, ar = 9 \times 3 = 27$$

$$\Rightarrow \boxed{3, 9, 27}$$

Case-2: $r = \frac{1}{3}$

Then the numbers are:

$$\bullet \frac{a}{r} = \frac{9}{1/3} = 27$$

$$\bullet a = 9$$

$$\bullet ar = 9 \cdot \frac{1}{3} = 3$$

So the numbers are:

$$27, 9, 3$$

Therefore, the required numbers are 3, 9, 27.

27. (d) Let the three numbers in GP be:

$$\frac{a}{r}, a, ar$$

Their product is:

$$\left(\frac{a}{r}\right) \times a \times (ar) = a^3$$

$$\text{i.e., } a^3 = 512$$

$$a = \sqrt[3]{512} = 8$$

Therefore, the second number is $a = 8$

28. (c) According to question, we have

$$t_2 = \frac{3}{4}$$

$$\Rightarrow ar = \frac{3}{4}$$

$$\Rightarrow a = \frac{3}{4r}$$

...(1)

Also, Sum = 4 i.e.,

$$S = 4$$

$$\Rightarrow \frac{a}{1-r} = 4$$

$$\Rightarrow \frac{3}{16} = r(1-r)$$

$$\Rightarrow r(1-r) = \frac{1}{4} \left(\frac{3}{4}\right)$$

$$\Rightarrow r(1-r) = \frac{1}{4} \left(1 - \frac{1}{4}\right)$$

On comparing, we get

$$\Rightarrow r = \frac{1}{4}$$

$$\text{Therefore, } a = \frac{3}{4r} = \frac{3}{4 \times \frac{1}{4}} = 3$$

Hence, option (c) is correct.

29. (b) Let the three terms of the G.P. be:

$$\frac{a}{r}, a, ar$$

According to question, we have

$$\frac{a}{r} + a + ar = \frac{21}{2}$$

$$\left(\frac{a}{r}\right) \cdot a \cdot ar = a^3 = 27$$

$$\Rightarrow a = 3$$

Put the value of a in above equation, we get

$$\frac{3}{r} + 3 + 3r = \frac{21}{2}$$

$$\frac{6}{r} + 6 + 6r = 21$$

$$\frac{6}{r} + 6r = 15$$

$$6 + 6r^2 = 15r$$

$$\Rightarrow 6r^2 - 15r + 6 = 0$$

Use the quadratic formula:

$$r = \frac{15 \pm \sqrt{(-15)^2 - 4(6)(6)}}{2(6)} = \frac{15 \pm \sqrt{225 - 144}}{12}$$

$$= \frac{15 \pm \sqrt{81}}{12} = \frac{15 \pm 9}{12}$$

$$r = \frac{24}{12} = 2 \text{ or } r = \frac{6}{12} = \frac{1}{2}$$

Case-1; $r = 2, a = 3$

Terms; $\frac{3}{2}, 3, 6$

Case-2; $r = \frac{1}{2}, a = 3$

Terms; $6, 3, \frac{3}{2}$

Therefore, $\frac{2}{3}$ is not the term of the given G.P.

30. (b) Go by options:

Option (a); 12, 18, 40

Clearly, 12, 18, 40 are not in G.P since common ratio is not constant i.e., $\frac{18}{12} \neq \frac{40}{18}$

Option (b); 10, 20, 40

Clearly, they are in G.P

Sum of numbers = $10 + 20 + 40 = 70$

Now, on multiplying two extremes each by 4 and the means by 5, we get 40, 100 and 160

Therefore, $100 - 40 = 60$ and $160 - 100 = 60$

Clearly, they are in A.P

Hence, 10, 20, 40 satisfies all the given conditions.

31. (a) Since, $x, 8, y$ are in G.P, the middle term squared equals the product of the first and third terms:

$$8^2 = x \times y \Rightarrow 64 = xy \quad \dots(1)$$

Since, $x, y, -8$ are in A.P, twice the middle term equals the sum of the first and third terms:

$$2y = x + (-8) \Rightarrow 2y = x - 8 \quad \dots(2)$$

From eq. (2), we have

$$x = 2y + 8$$

Therefore, eq.(1) will becomes

$$64 = y(2y + 8) = 2y^2 + 8y$$

$$2y^2 + 8y - 64 = 0$$

$$y^2 + 4y - 32 = 0$$

$$y = \frac{-4 \pm \sqrt{4^2 - 4 \times 1 \times (-32)}}{2} = \frac{-4 \pm \sqrt{16 + 128}}{2}$$

$$= \frac{-4 \pm \sqrt{144}}{2}$$

$$y = \frac{-4 \pm 12}{2}$$

$$\bullet y = \frac{-4 + 12}{2} = \frac{8}{2} = 4$$

$$\bullet y = \frac{-4 - 12}{2} = \frac{-16}{2} = -8$$

Therefore, the value of x will be;

$$\bullet \text{ For } y = 4; x = 2(4) + 8 = 8 + 8 = 16$$

$$\bullet \text{ For } y = -8; x = 2(-8) + 8 = -16 + 8 = -8$$

Therefore, (16, 4), (-8, -8) are the required pairs.

Hence, out of the given options, option (a) is correct.

32. (b) Let the two numbers be a and b .

Step 1: Use A.M. formula

$$\text{A.M.} = \frac{a+b}{2} = 6.5 \Rightarrow a+b = 13$$

Step 2: Use G.M. formula

$$\text{G.M.} = \sqrt{ab} = 6 \Rightarrow ab = 36$$

We now have,

$$\bullet a + b = 13$$

$$\bullet ab = 36$$

Clearly, option (b) satisfies both the above conditions i.e.,

$$9 + 4 = 13 \text{ and } 9 \times 4 = 36$$

Hence, option (b) is correct.

Chapter Wrap-up Test

Ready to test your knowledge?

You've got 15 questions and 20 minutes - go for it!

1. The 20th term of the progression

1, 4, 7, 10,.....is

- (a) 58 (b) 52
(c) 50 (d) None of these

2. If the fifth term of the G.P is four times the third term, then the common ratio is

- (a) ± 4 (b) ± 3
(c) ± 2 (d) None of these

3. The nth term of the sequence

1, 3, 5, 7,.....is

- (a) n (b) $2n - 1$
(c) $2n + 1$ (d) None of these

4. If 4th, 7th and 10th terms of a Geometric Progression are p, q and r respectively, then;

- (a) $p^2 = q^2 + r^2$ (b) $p^2 = qr$
(c) $q^2 = pr$ (d) $pqr + pq + 1 = 0$

5. The sum of n terms of the series

$1 + 3 + 5 + \dots$ is

- (a) n^2 (b) $2n^2$
(c) $\frac{n^2}{2}$ (d) None

6. The last term of the series 5, 7, 9, to 21 terms is

- (a) 44 (b) 43
(c) 45 (d) None of these

7. In a G.P., sixth term is 729 and the common ratio is 3, then the first term of G.P is

- (a) 2 (b) 3
(c) 4 (d) 7

8. The sum of five terms of AP is 75, find the 3rd term.

- (a) 20 (b) 30
(c) 15 (d) None of these

9. The value of K for which the terms $7K + 3$, $4K - 5$, $2K + 10$ are in A.P. is

- (a) -13 (b) -23
(c) 13 (d) 23

10. Find the sum of the infinite geometric progression 3, 1.5, 0.75,.....

- (a) 4
(b) 6
(c) 8
(d) Cannot be determined

11. Find the 17th term of an AP series if 15th and 21st terms are 30.5 and 39.5 respectively.

- (a) 33.5 (b) 35.5
(c) 36.0 (d) 38.0

12. Divide 144 into three parts which are in A.P and such that the largest is twice the smallest, the smallest of three numbers will be:

- (a) 48 (b) 36
(c) 13 (d) 32

13. The sum of the first eight terms of a G.P. is five times the sum of the first four terms, then the common ratio is

- (a) $\pm \sqrt{2}$ (b) $\sqrt{2}$
(c) $-\sqrt{2}$ (d) None of these

14. The 4 arithmetic means between -2 and 23 are

- (a) 3, 13, 8, 18 (b) 18, 3, 8, 13
(c) 3, 8, 13, 18 (d) None of these

15. The common ratio of a G.P. is 3, and the last term is 486. If the sum of these terms is 728, find the first term.

- (a) 2 (b) 5
(c) 6 (d) 3

ANSWER KEY

1. (a) 2. (c) 3. (b) 4. (b) 5. (a) 6. (c) 7. (b) 8. (c) 9. (b) 10. (b)
11. (a) 12. (d) 13. (a) 14. (c) 15. (a)





Sets, Relations and Functions, Limits and Continuity

Cheat Sheet by Anurag Sir

UNIT-I: SETS, RELATIONS AND FUNCTIONS

Sets

Collection of well-defined objects or elements.

Representation of Sets;

- ❑ **Roster/Tabular form:** Elements are written in brackets {}, separating them by commas.

Ex: $A = \{a, e, i, o, u\}$ represents a set of vowels.

- ❑ **Set Builder form:** Defining a common property or rule that all elements in the set possess, and no element outside the set possesses.

Ex: $C = \{x \mid x \text{ is an even number}\}$ represents a set of all even numbers. Here, the property or rule is that the elements must be even numbers.

Some Special Sets

- ❑ **Finite Set:** Sets having countable number of elements.
- ❑ **Infinite Set:** Sets having uncountable number of elements.
- ❑ **Null/Empty Set:** Set which does not contain any element.
- ❑ **Singleton Set:** Set containing only one element.
- ❑ **Equal set:** Sets having exactly same elements.
- ❑ **Equivalent set:** Sets having same cardinality, i.e., they contain the same number of elements.
- ❑ **Disjoint set:** Sets having no common elements.

- ❑ **Subset:** For two sets A and B , if every element of A is also an element of set B , then A is said to be subset of B . It can be expressed as $A \subseteq B$.
- ❑ **Superset:** If A is a subset of B , then B is a superset of A . It can be expressed as $B \supset A$.
- ❑ **Proper set:** For two sets A and B , if A is a subset of B , but A is not equal to B , then A is called a proper subset of B , denoted as $A \subset B$.
- ❑ **Power set:** Set of all possible subsets of the given set. It is denoted by $P(A)$. The total number of sets having n elements will be 2^n .

Cardinal Number

For the finite sets A and B , then

- ❑ $n(A \cup B) = n(A) + n(B) - n(A \cap B)$
- ❑ $n(A \cup B \cup C) = n(A) + n(B) + n(C) - n(A \cap B) - n(B \cap C) - n(C \cap A) + n(A \cap B \cap C)$
- ❑ $n(B - A) = n(B) - n(A \cap B)$

Operation on sets:

- ❑ **Union of two sets:**

$$A \cup B = \{x : x \in A \text{ or } x \in B\}$$

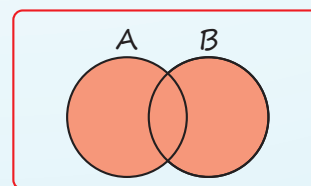

□ **Intersection of two sets:**

$$A \cap B = \{x : x \in A \text{ and } x \in B\}$$

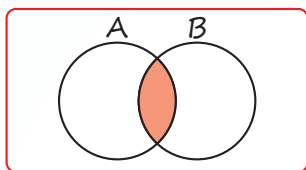

□ **Difference of two sets:**

$$A - B = \{x : x \in A \text{ and } x \notin B\}$$

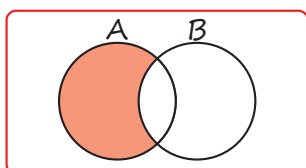

□ **Complement of set:**

$$A' = \{x : x \in U \text{ and } x \notin A\} \text{ i.e., } A^c = U - A$$

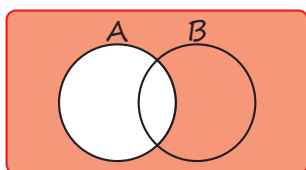

□ **Symmetric Difference of two sets:**

$$A \Delta B = (A - B) \cup (B - A)$$

Cartesian Product of Sets

For two non-empty sets A and B, set of all ordered pairs (a, b) such that $a \in A$ and $b \in B$. It is denoted by $A \times B$.

$$\text{i.e., } A \times B = \{(a, b) : a \in A \text{ and } b \in B\}$$

Relation

- Domain (R) = $\{a : (a, b) \in R\}$
- Range (R) = $\{b : (a, b) \in R\}$
- **Reflexive Relation:** $(a, a) \in R$ for all $a \in A$.
- **Symmetric Relation:** $(a, b) \in R \Rightarrow (b, a) \in R$ for all $a, b \in A$.
- **Transitive Relations:** $(a, b) \in R$ and $(b, c) \in R \Rightarrow (a, c) \in R$, for all $a, b, c \in A$.

A relation that is Reflexive, Symmetric and Transitive is called an Equivalence relation.

Function

The relation 'f' from set A to B is a function if and only if every element of A has a unique image in B. It is denoted by $X \rightarrow Y$.

Type of functions

- **One to One function:** for $x_1 \neq x_2$ for $x_1, x_2 \in X \Rightarrow f(x_1) \neq f(x_2)$
- **Many to One function:** For $x_1 \neq x_2$ for $x_1, x_2 \in X \Rightarrow f(x_1) = f(x_2)$
- **Into Function:** The mapping f is said to be into if there is at least one element in Y that has no pre-image in X.
- **Onto Function:** The mapping f is said to be onto if every element in Y has at least one pre-image in X.

QUESTIONS

Sets

1. $(A \cup B)'$ is equal to [MTP-Jan., 2025]
 - (a) $(A' \cup B)'$
 - (b) $A' \cap B'$
 - (c) $A' \cup B'$
 - (d) None of these
2. If $A = \{1, 2, 3, 4, 5\}$, $B = \{2, 4\}$ and $C = \{1, 3, 5\}$ then $(A - C) \times B$ is:

[MTP-Jan., 2025, MTP-June, 2023]

 - (a) $\{(2, 2) (2, 4) (4, 2) (4, 4) (5, 2) (5, 4)\}$
 - (b) $\{(1, 2) (1, 4) (3, 2) (3, 4) (5, 2) (5, 4)\}$
 - (c) $\{(2, 2) (4, 2) (4, 4) (4, 5)\}$
 - (d) $\{(2, 2) (2, 4) (4, 2) (4, 4)\}$

3. If $A = \{1, 2, 3, 4\}$, $B = \{2, 4, 6, 8\}$ and $C = \{3, 4, 5, 6\}$, then value of $A - (B \cup C)$ is [PYQ-May, 2025]
 - (a) $\{1, 2, 3\}$
 - (b) $\{2, 3, 4, 5\}$
 - (c) $\{1\}$
 - (d) $\{0\}$
4. If $A = \{a, b, c, d, e\}$, then the number of proper subsets is [PYQ-Jan., 2025]
 - (a) 32
 - (b) 31
 - (c) 30
 - (d) 29
5. The number of proper subsets of the set $\{3, 4, 5, 6, 7\}$ is [MTP-June, 2024]
 - (a) 32
 - (b) 31
 - (c) 30
 - (d) 25

6. If a set contains n elements, then the total number of proper subsets of the set is:
 (a) $2^n - 1$ (b) 2^n
 (c) $2^n - 1$ (d) $2^n - 2$
7. $A = \{a, b, p\}$, $B = \{2, 3\}$ and $C = \{p, q, r, s\}$, then $n[(A \cup C) \times B]$ is; [PYQ-Jan., 2025]
 (a) 20 (b) 8
 (c) 12 (d) 16
8. If $A = \{1, 2, 3\}$, $B = \{3, 4\}$ and $C = \{4, 5, 6\}$, then $A \times (B \cap C)$ [MTP-June, 2022]
 (a) $\{(1, 2), (1, 4), (2, 4), (3, 4)\}$
 (b) $\{(4, 4), (4, 3), (4, 1)\}$
 (c) $\{(3, 4), (2, 4)\}$
 (d) $\{(1, 4), (2, 4), (3, 4)\}$
9. If $A = (a, b, c)$, $B = (b, c, d)$ and $C = (a, d, c)$, then $(A - B) \times (B \cap C)$ [PYQ-June, 2023]
 (a) $\{(a, d), (c, d)\}$ (b) $\{(a, c), (a, d)\}$
 (c) $\{(c, a), (d, a)\}$ (d) $\{(a, c), (a, d), (b, d)\}$
10. There are 40 students, 30 of them passed in English, 25 of them passed in Maths and 15 of them passed in both. Assuming that every Student has passed atleast in one subject. How many student's passed in English only but not in Maths. [MTP-Jan., 2025]
 (a) 15 (b) 20
 (c) 10 (d) 25
11. A town has a total population of 50,000. Out of it 28,000 read the newspaper X and 23,000 read Y while 4,000 read both the papers. The number of persons not reading X and Y both is - [PYQ-Sept 2024, MTP-May 2025, MTP-Jan 2025]
 (a) 2,000 (b) 3,000
 (c) 2,500 (d) None of these
12. Two finite sets have m and n elements. The total number of subsets of first set is 56 more than the total number of subsets of the second set. The value of m and n are [PYQ-Nov., 2022]
 (a) 6, 3 (b) 7, 6
 (c) 5, 1 (d) 8, 7
13. A survey shows that 74% of the Canadian like grapes, whereas 68% like bananas. What percentage of the Canadians like both grapes and bananas, if everybody like either of two? [MTP-June, 2023]
 (a) 32% (b) 26%
 (c) 6% (d) 42%
14. In a survey of 300 companies, the number of companies using different media-Newspapers (N), Radio (R) and Television (T) are as follows: $n(N) = 200$, $n(R) = 100$, $n(T) = 40$, $n(N \cap R) = 50$, $n(R \cap T) = 20$, $n(N \cap R) = 25$, and $n(N \cap R \cap T) = 5$. Find the numbers of companies using none of these media: [MTP-Sept., 2024]
 (a) 20 companies (b) 250 companies
 (c) 30 companies (d) 50 companies
15. In a town of 20,000 families it was found that 40% families buy newspaper A , 20% families buy newspaper B and 10% families buy newspaper C , 5% families buy A and B , 3% buy B and C and 4% buy A and C . If 2% families buy all the three newspaper, then the number of families which buy A only is: [MTP-June, 2024]
 (a) 6600 (b) 6300
 (c) 5600 (d) 600
16. Out of total 150 students, 45 passed in Accounts, 30 in Economics and 50 in Maths, 30 in both Accounts and Maths, 32 in both Maths and Economics, 35 in both Accounts and Economics, 25 students passed in all the three subjects. Find the numbers who passed atleast in anyone of the subjects: [MTP-June, 2023]
 (a) 63 (b) 53
 (c) 73 (d) None

Relations

17. Let R be a relation on N defined by $x + 2y = 8$. The domain of R is: [MTP-June., 2022]
 (a) $\{2, 4, 8\}$ (b) $\{2, 4, 6, 8\}$
 (c) $\{2, 4, 6\}$ (d) $\{1, 2, 3, 4\}$
18. If $A = \{1, 2, 3\}$ then the relation $R = \{(1, 1), (2, 3), (2, 2), (3, 3), (1, 2)\}$ on A is: [MTP-Jan., 2025]
 (a) Reflexive (b) Symmetric
 (c) Transitive (d) Equivalence
19. On the set of lines, being perpendicular is a satisfies which property: [MTP-June, 2024]
 (a) Reflexive (b) Symmetric
 (c) Transitive (d) None of these
20. Let $A = \{1, 2, 3\}$ and consider the relation $R = \{(1, 1), (2, 2), (3, 3), (1, 2), (2, 3), (1, 3)\}$, then R is [PYQ-Sept., 2024, MTP-Sept., 2024]
 (a) Reflexive but not symmetric
 (b) Reflexive but not transitive
 (c) Symmetric and Transitive
 (d) Neither symmetric nor transitive

21. Which of the following relations is transitive but not reflexive for the set $S = \{3, 4, 6\}$?

[PYQ-May, 2025]

- (a) $R = \{(3, 4), (4, 6), (3, 6)\}$
 (b) $R = \{(1, 2), (1, 3), (1, 4)\}$
 (c) $R = \{(3, 3), (4, 4), (6, 6)\}$
 (d) $R = \{(3, 4), (4, 3)\}$

22. Consider the following relations on $A = \{1, 2, 3\}$, $R = \{(1, 1), (1, 2), (1, 3)\}$, $S = \{(1, 1), (1, 2), (2, 2), (3, 3)\}$, $T = \{(1, 1), (1, 2), (2, 2), (2, 3)\}$, and $\phi =$ empty set. Which one of these forms an equivalence relation?

[PYQ-June, 2024]

- (a) R (b) S
 (c) T (d) ϕ

Functions

23. If $f(x) = x^2 + x - 1$ and $4f(x) = f(2x)$, then find the value of x :

[PYQ-Sept., 2024]

- (a) $\frac{2}{3}$ (b) $\frac{3}{2}$
 (c) $\frac{3}{4}$ (d) $\frac{4}{3}$

24. Given the function $f(x) = (2x + 3)$, then the value of $f(2x) - 2f(x) + 3$ will be:

[MTP-June, 2024]

- (a) 3 (b) 2
 (c) 1 (d) 0

25. The domain of the function $f(x) = \frac{x^2 + 3x + 5}{x^2 - 5x + 4}$

[MTP-June, 2022]

- (a) R (b) $R - \{1, 4\}$
 (c) $R - \{1\}$ (d) $\{1, 4\}$

26. The range of the function $f(x) = 3x - 2$ is

[PYQ-May, 2025]

- (a) $(-\infty, \infty)$ (b) $R - \{3\}$
 (c) $(-\infty, 0)$ (d) $(0, -\infty)$

27. If $f(x) = \frac{1}{x} - x$, $f\left(\frac{1}{2}\right)$ is

[MTP-May, 2025]

- (a) $\frac{3}{2}$ (b) $\frac{2}{3}$
 (c) 1 (d) 0

28. If $f(p) = \frac{1}{1-p}$, then f^{-1} is

[PYQ-Nov., 2022]

- (a) $1 - p$ (b) $\frac{p-1}{p}$
 (c) $\frac{p}{p-1}$ (d) $\frac{1}{p}$

29. If $f(x) = \frac{1}{1-x}$ and $g(x) = \frac{x-1}{x}$, then $gof(x)$ is

[MTP-Jan., 2025]

- (a) $x - 1$ (b) x
 (c) $\frac{1}{x}$ (d) None of these

30. If $f(x) = x + 3$, $g(x) = x^2$, then $fog(x)$

[MTP-May, 2025]

- (a) $x^2 + 3$ (b) $x^2 + x + 3$
 (c) $(x+3)^2$ (d) None of these

31. Find fog of the functions $f(x) = x^8$, $g(x) = 2x^2 + 1$

[MTP-May 2025, MTP-June 2024]

- (a) $x^4(2x^2 + 1)$ (b) x^8
 (c) $2x^2 + 1$ (d) $(2x^2 + 1)^8$

32. If $f(x) = x + 2$, $g(x) = 7^x$, then $gof(x)$ is

[MTP-Sept., 2024]

- (a) $7x^{x+2} \cdot 7^x$ (b) $7^x + 2$
 (c) 49^{7^x} (d) None of these

33. Let R is the set of real number, such that the function $f: R \rightarrow R$ and $g: R \rightarrow R$ are defined by $f(x) = x^2 + 3x + 1$ and $g(x) = 2x - 3$. Find (fog) :

[MTP-June, 2024]

- (a) $4x^2 + 6x + 1$ (b) $x^2 + 6x + 1$
 (c) $4x^2 - 6x + 1$ (d) $x^2 - 6x + 1$

34. If $f(x) = x^2 + 2$, then the given function is

[MTP-May, 2025]

- (a) Odd function
 (b) Even function
 (c) Neither odd or even function
 (d) None of these

35. The function $f(x) = 2^x$ is

[MTP-May, 2025]

- (a) one-one mapping (b) one-many
 (c) many-one (d) None of these

ANSWER KEY

- | | | | | | | | | | |
|---------|---------|---------|---------|---------|---------|---------|---------|---------|---------|
| 1. (b) | 2. (d) | 3. (c) | 4. (b) | 5. (b) | 6. (a) | 7. (c) | 8. (d) | 9. (b) | 10. (a) |
| 11. (b) | 12. (a) | 13. (d) | 14. (d) | 15. (a) | 16. (b) | 17. (c) | 18. (a) | 19. (b) | 20. (a) |
| 21. (a) | 22. (b) | 23. (b) | 24. (d) | 25. (b) | 26. (a) | 27. (a) | 28. (b) | 29. (b) | 30. (a) |
| 31. (d) | 32. (c) | 33. (c) | 34. (b) | 35. (a) | | | | | |

HINTS & SOLUTIONS

1. (b) We know that,
By De Morgan's Law
 $(A \cup B)' = A' \cap B'$

2. (d) We are given:
• $A = \{1, 2, 3, 4, 5\}$
• $B = \{2, 4\}$
• $C = \{1, 3, 5\}$

Therefore,

$$A - C = \{\text{Elements in } A \text{ but not in } C\} = \{2, 4\}$$

This is the Cartesian Product of two sets:

$$\begin{aligned} &\{2, 4\} \times \{2, 4\} \\ &= \{(2, 2), (2, 4), (4, 2), (4, 4)\} \end{aligned}$$

3. (c) Given; $A = \{1, 2, 3, 4\}$, $B = \{2, 4, 6, 8\}$ and $C = \{3, 4, 5, 6\}$

$$\text{Thus, } B \cup C = \{2, 3, 4, 5, 6, 8\}$$

Therefore, $A - (B \cup C) = \text{Elements in } A \text{ but not in } B \cup C = \{1, 2, 3, 4\} - \{2, 3, 4, 5, 6, 8\} = \{1\}$

4. (b) Given; $A = \{a, b, c, d, e\}$

Here, number of elements in set A (n) = 5

$$\begin{aligned} \text{Therefore, the number of proper subsets} &= 2^n - 1 \\ &= 2^5 - 1 = 31 \end{aligned}$$

5. (b) Set: $\{3, 4, 5, 6, 7\}$

It has 5 elements

$$\begin{aligned} \text{Total subsets of a set with } n \text{ elements} &= 2^n = 2^5 \\ &= 32 \end{aligned}$$

Proper subsets = Total subsets - 1 (Excluding the set itself) = $32 - 1 = 31$

6. (a)

- The total number of subsets of a set with n elements is 2^n .
- A proper subset is any subset excluding the set itself.

So, number of proper subsets = $2^n - 1$

7. (c) Given; $A = \{a, b, p\}$, $B = \{2, 3\}$ and $C = \{p, q, r, s\}$

$$\text{Thus, } A \cup C = \{a, b, p, q, r, s\}$$

Here, number of elements in $A \cup C$ is 6 and in C is 2.

Therefore, cardinal number of $n[(A \cup C) \times B]$ is $6 \times 2 = 12$

8. (d) Given, $A = \{1, 2, 3\}$, $B = \{3, 4\}$ and $C = \{4, 5, 6\}$

$$\Rightarrow (B \cap C) = \{4\}$$

$$\text{Now, } A \times (B \cap C) = \{1, 2, 3\} \times \{4\}$$

$$= \{(1, 4), (2, 4), (3, 4)\}$$

9. (b) Given; $A = \{a, b, c\}$, $B = \{b, c, d\}$ and $C = \{a, d, c\}$

Thus,

$$A - B = \{a, b, c\} - \{b, c, d\}$$

$$\Rightarrow A - B = \{a, d\}$$

$$\text{Now, } (B \cap C) = \{b, c, d\} \cap \{a, d, c\} = \{c, d\}$$

$$\text{Therefore, } (A - B) \times (B \cap C) = \{a, d\} \times \{c, d\}$$

$$= \{(a, c), (a, d)\}$$

10. (a) Let $A =$ set of students who passed English and $B =$ set of students who passed Maths

According to the question, we have

$$n(A) = 30$$

$$n(B) = 25$$

$$n(A \cap B) = 15$$

Total students = 40, and everyone passed at least one subject.

Therefore, the number of students who passed only English = $n(A - B)$

Therefore,

$$n(A - B) = n(A) - n(A \cap B) = 30 - 15 = 15$$

11. (b) We are given:

- Total population = 50,000
- People who read newspaper $X = 28,000$
- People who read newspaper $Y = 23,000$
- People who read both = 4,000

We are to find the number of people who read neither X nor Y .

$$\begin{aligned} \text{People who read } X \text{ or } Y &= X + Y - \text{Both} \\ &= 28,000 + 23,000 - 4,000 = 47,000 \end{aligned}$$

$$\begin{aligned} \text{Therefore, People who read neither } X \text{ nor } Y \\ &= 50,000 - 47,000 = 3,000 \end{aligned}$$

12. (a) Given: Number of elements in two finite sets = m and n

Thus, the number of subsets in first set = 2^m

Number of subsets in second set = 2^n

According to the question,

$$2^m = 2^n + 56$$

For option (a): 6,3

$$\text{LHS} = 2^6 = 64$$

$$\text{RHS} = 2^3 + 56 = 8 + 56 = 64$$

Thus, LHS = RHS

Therefore, the value of m and n are 6 and 3 respectively.

13. (d) Let $n(A) = 74\%$ (Grapes) & $n(B) = 68\%$ (Banana)

$$\text{Also, } n(A \cup B) = 100\%$$

We know,

$$n(A \cap B) = n(A) + n(B) - n(A \cup B)$$

$$\Rightarrow n(A \cap B) = 74 + 68 - 100$$

$$\Rightarrow n(A \cap B) = 42\%$$

Therefore, 42% of the Canadians like both grapes and bananas.

14. (d) Given

Given:

- Total companies, $n(U) = 300$
- $n(N) = 200$
- $n(R) = 100$
- $n(T) = 40$
- $n(N \cap R) = 50$
- $n(R \cap T) = 20$
- $n(N \cap T) = 25$
- $n(N \cap R \cap T) = 5$

We know,

$$\text{Number of companies using none of these media} = n(U) - n(N \cup R \cup T)$$

Now,

$$\begin{aligned} n(N \cup R \cup T) &= n(N) + n(R) + n(T) - n(N \cap R) - \\ & n(R \cap T) - n(N \cap T) + n(N \cap R \cap T) \\ &= 200 + 100 + 40 - 50 - 20 - 25 + 5 \\ &= 340 - 95 + 5 = 250 \end{aligned}$$

Therefore,

$$\begin{aligned} n(\text{none}) &= n(U) - n(N \cup R \cup T) \\ &= 300 - 250 = 50 \end{aligned}$$

15. (a) Given;

- $n(A) = 8000$
- $n(B) = 4000$
- $n(C) = 2000$
- $n(A \cap B) = 1000$
- $n(B \cap C) = 600$
- $n(A \cap C) = 800$
- $n(A \cap B \cap C) = 400$

To Find: Number of families that buy only A i.e.,

$$n(A \cap B^c \cap C^c) = n(A) - n(A \cap B) - n(A \cap C) + n(A \cap B \cap C)$$

$$\begin{aligned} n(A \cap B^c \cap C^c) &= 8000 - 1000 - 800 + 400 \\ &= 6600 \end{aligned}$$

16. (b) Given;

Out of total 150 students,

- 45 passed in **Accounts** (A)
- 30 in **Economics** (E)
- 50 in **Maths** (M)
- 30 in both **Accounts and Maths** ($A \cap M$)
- 32 in both **Maths and Economics** ($M \cap E$)
- 35 in both **Accounts and Economics** ($A \cap E$)
- 25 passed in **all three** subjects ($A \cap E \cap M$)

Therefore, the numbers of students who passed atleast in anyone of the subjects is given by

$$\begin{aligned} n(A \cup E \cup M) &= n(A) + n(E) + n(M) - n(A \cap E) - \\ & n(E \cap M) - n(M \cap A) + n(A \cap E \cap M) \\ &= 45 + 30 + 50 - 35 - 32 - 30 + 25 \\ &= 125 - 97 + 25 = 53 \end{aligned}$$

17. (c) Given relation: $x + 2y = 8$

$$\Rightarrow 2y = 8 - x$$

$$\Rightarrow y = \frac{8-x}{2}$$

Since, the relation R is on N i.e., x and y should be natural numbers that satisfies the given relation:

If $x = 1$, then $y = 3.5$, which is not natural number

If $x = 2$, then $y = 3$

If $x = 3$, then $y = 2.4$, which is not natural number

If $x = 4$, then $y = 2$

If $x = 6$, then $y = 1$

If $x = 8$, then $y = 0$, which is not natural number

Therefore, the possible values of $x = \{2, 4, 6\}$

Hence, Domain of $R = \{2, 4, 6\}$

18. (a) We are given:

• Set: $A = \{1, 2, 3\}$

• Relation: $R = \{(1, 1), (2, 3), (2, 2), (3, 3), (1, 2)\}$

(a) Reflexive:

A relation is reflexive if all $(a, a) \in R$ for all $a \in A$.

Here,

• $(1, 1) \in R$

• $(2, 2) \in R$

• $(3, 3) \in R$

So, R is reflexive

(b) Symmetric:

A relation is symmetric if for every $(a, b) \in R$, $(b, a) \in R$.

• $(1, 2) \in R$, but $(2, 1) \notin R$

• $(2, 3) \in R$, but $(3, 2) \notin R$

So, R is not symmetric

(c) Transitive:

A relation is transitive if whenever $(a, b) \in R$ and $(b, c) \in R$, then $(a, c) \in R$

• $(1, 2), (2, 3) \in R$, so we need $(1, 3) \in R \rightarrow$ it's not

So, R is not transitive

Therefore, the given relation is reflexive.

19. (b)

(a) Reflexive:

A relation R is reflexive if $l_1 \perp l_1$ (a line is perpendicular to itself).

\rightarrow A line cannot be perpendicular to itself.

(b) Symmetric:

A relation is symmetric if $l_1 \perp l_2$ implies $l_2 \perp l_1$.

\rightarrow If one line is perpendicular to another, the reverse is also true.

(c) Transitive:

A relation is transitive if $l_1 \perp l_2$ and $l_2 \perp l_3$ implies $l_1 \perp l_3$.

\rightarrow This is not true. In fact, l_1 and l_3 would be parallel (both perpendicular to l_2), not perpendicular to each other.

Therefore, the given relation is symmetric.

20. (a) A relation is reflexive if all $(a, a) \in R$ for all $a \in A$.

Here, we have:

$(1, 1), (2, 2), (3, 3) \in R$

Thus, it is reflexive.

A relation is symmetric if for every $(a, b) \in R$, the pair (b, a) is also in R .

• $(1, 2) \in R$, but $(2, 1) \notin R$

• $(2, 3) \in R$, but $(3, 2) \notin R$

• $(1, 3) \in R$, but $(3, 1) \notin R$

So, R is not symmetric

A relation is transitive if whenever $(a, b) \in R$ and $(b, c) \in R$, then $(a, c) \in R$.

• $(1, 2), (2, 3) \in R \rightarrow (1, 3) \in R$.

So, R is transitive.

Hence, option (a) is correct.

21. (a) Given set: $S = \{3, 4, 5\}$

Option (a): $R = \{(3, 4), (4, 6), (3, 6)\}$

Clearly, it is not reflexive but is transitive i.e.,

$(3, 4) \in R$ & $(4, 6) \in R \Rightarrow (3, 6) \in R$ which is true.

Option (b): $R = \{(1, 2), (1, 3), (1, 4)\}$

Since, $1 \notin S$ thus the above relation is not transitive.

Option (c): $R = \{(3, 3), (4, 4), (6, 6)\}$

Clearly, it is reflexive set.

Option (d): $R = \{(3, 4), (4, 3)\}$

Here, $(3, 4) \in R$ and $(4, 3) \in R$ but $(3, 3) \notin R$.

Hence, $R = \{(3, 4), (4, 6), (3, 6)\}$ is transitive but not reflexive set.

22. (b) Given:

Relations:

- $R = \{(1, 1), (1, 2), (1, 3), (3, 3)\}$
- $S = \{(1, 1), (1, 2), (2, 1), (2, 2), (3, 3)\}$
- $T = \{(1, 1), (1, 2), (2, 2), (2, 3)\}$
- $\phi = \phi$ (empty set)

1. Relation R

- Reflexive?

Does $(2, 2) \in R$? No. So not reflexive.

- Symmetric?

$(1, 2) \in R$, but $(2, 1) \notin R$. So not symmetric.

Thus, R is not an equivalence relation.

2. Relation S

- Reflexive?

$(1, 1), (2, 2), (3, 3) \in S$, so reflexive.

- Symmetric?

$(1, 2) \in S$ and $(2, 1) \in S$, so symmetric pairs exist.

- Transitive?

Check:

- $(1, 2), (2, 1) \in S$ implies $(1, 1) \in S$ — true.
- $(1, 2), (2, 2) \in S$ implies $(1, 2) \in S$ — true.
- No other pairs to check that violate transitivity.

Thus, S is an equivalence relation.

3. Relation T

- Reflexive?

Is $(3, 3) \in T$? No, So not reflexive.

- Symmetric?

$(1, 2) \in T$ but $(2, 1) \notin T$, so not symmetric.

Thus, T is not an equivalence relation.

4. Relation ϕ (empty set)

- Reflexive?

No elements, so no (a, a) — not reflexive.

Therefore, ϕ is not an equivalence relation.

23. (b) Given:

$$f(x) = x^2 + x - 1$$

$$\text{Then, } 4f(x) = 4(x^2 + x - 1) = 4x^2 + 4x - 4$$

$$f(2x) = (2x)^2 + 2x - 1 = 4x^2 + 2x - 1$$

Since, $4f(x) = f(2x)$, thus

$$4x^2 + 4x - 4 = 4x^2 + 2x - 1$$

$$\Rightarrow 4x - 4 = 2x - 1$$

$$\Rightarrow 4x - 2x = -1 + 4$$

$$\Rightarrow 2x = 3$$

$$\Rightarrow x = \frac{3}{2}$$

24. (d) Given;

$$f(x) = 2x + 3$$

To find

$$f(2x) - 2f(x) + 3$$

$$\bullet f(2x) = 2(2x) + 3 = 4x + 3$$

$$\bullet 2f(x) = 2(2x + 3) = 4x + 6$$

Now,

$$f(2x) - 2f(x) + 3 = (4x + 3) - (4x + 6) + 3 = -3 + 3 = 0$$

25. (b) Given function, $f(x) = \frac{x^2 + 3x + 5}{x^2 - 5x + 4}$

$$\text{Put } x^2 - 5x + 4 = 0$$

$$\Rightarrow x^2 - 4x - x + 4 = 0$$

$$\Rightarrow x(x - 4) - 1(x - 4)$$

$$\Rightarrow (x - 1)(x - 4) = 0$$

$$\Rightarrow x = 1 \text{ or } x = 4$$

For domain, denominator should not be equal to zero.

Thus, Domain of given function = $\mathbb{R} - \{1, 4\}$

26. (a) A linear function with a non-zero slope always has a range of all real numbers.

So, Range of $f(x) = 3x - 2$ is $(-\infty, \infty)$

27. (a) Given, $f(x) = \frac{1}{x} - x$

$$\Rightarrow f\left(\frac{1}{2}\right) = \frac{1}{\frac{1}{2}} - \frac{1}{2}$$

$$\Rightarrow f\left(\frac{1}{2}\right) = 2 - \frac{1}{2}$$

$$\Rightarrow f\left(\frac{1}{2}\right) = \frac{3}{2}$$

28. (b) Given,

$$f(p) = \frac{1}{1-p}$$

$$\text{Let } y = f(p) = \frac{1}{1-p}$$

$$\Rightarrow y = \frac{1}{1-p}$$

$$\Rightarrow 1-p = \frac{1}{y}$$

$$\Rightarrow p = 1 - \frac{1}{y}$$

$$\Rightarrow f^{-1}(y) = \frac{y-1}{y}$$

$$\Rightarrow f^{-1}(p) = \frac{p-1}{p}$$

29. (b) We are given:

$$\bullet f(x) = \frac{1}{1-x}$$

$$\bullet g(x) = \frac{x-1}{x}$$

Thus, $g \circ f(x) = g(f(x))$

$$g(f(x)) = g\left(\frac{1}{1-x}\right)$$

$$= \frac{1}{1-x} - 1$$

$$= \frac{1-x}{1-x}$$

Simplify the numerator:

$$\frac{1}{1-x} - 1 = \frac{1-(1-x)}{1-x} = \frac{x}{1-x}$$

$$\text{Therefore, } g(f(x)) = \frac{\frac{x}{1-x}}{1-x} = x$$

30. (a) Given;

$$f(x) = x + 3$$

$$g(x) = x^2$$

$$(f \circ g)(x) = f(g(x))$$

$$\text{Therefore, } f(g(x)) = f(x^2) = x^2 + 3$$

31. (d) Given,

$$f(x) = x^8, g(x) = 2x^2 + 1$$

$$f \circ g(x) = f(g(x))$$

$$= f(2x^2 + 1)$$

$$= (2x^2 + 1)^8$$

32. (c) Given,

$$f(x) = x + 2, g(x) = 7^x,$$

$$\text{Thus, } g(f(x)) = g(x + 2) = 7^{x+2}$$

$$= 7^x \cdot 7^2 = 49 \cdot 7^x$$

33. (c) Given,

$$\bullet f(x) = x^2 + 3x + 1$$

$$\bullet g(x) = 2x - 3$$

Therefore, $f \circ g(x) = f(g(x))$

i.e.,

$$f(g(x)) = f(2x - 3) = (2x - 3)^2 + 3(2x - 3) + 1$$

$$= 4x^2 - 6x + 1$$

34. (b) Given; $f(x) = x^2 + 2$

$$\text{Thus, } f(-x) = (-x)^2 + 2$$

$$\Rightarrow f(-x) = x^2 + 2$$

$$\Rightarrow f(-x) = f(x)$$

Therefore, the given function is an even function.

35. (a)

• **One-one (injective):**

$$\text{Yes - If } f(x_1) = f(x_2), \text{ then } 2^{x_1} = 2^{x_2}$$

$$\Rightarrow x_1 = x_2$$

So, it passes the test for being one-one.

• **Not many-one:**

Because each input x gives a unique output.

• **Not one-many:**

A function by definition cannot assign multiple outputs to the same input.

Hence, the given function is one-one mapping.



Chapter Wrap-up Test

Ready to test your knowledge?

You've got 15 questions and 20 minutes - go for it!

1. If $A = \{1, 2, 3, 5, 7\}$ and

$$B = \{x^2 : x \in A\}, \text{ then}$$

(a) $n(B) < n(A)$

(b) $n(B) > n(A)$

(c) $n(B) = n(A)$

(d) Can't determine

2. If $P = \{1, 2, 3, 5, 7\}$, $Q = \{1, 3, 6, 10, 15\}$
Universal set $S = \{1, 2, 3, 4, 5, 6, 7, 8, 9, 10, 11, 12, 13, 14, 15\}$. The cardinal number of $P \cup Q$ is

(a) 10

(b) 9

(c) 8

(d) None of these

3. The inverse function of $f(y) = 3y$ is

(a) $\frac{1}{3y}$

(b) $\frac{y}{3}$

(c) $-3y$

(d) $\frac{1}{y}$

4. If $f : R \rightarrow R$, $f(x) = x + 1$, $g : R \rightarrow R$, $g(x) = x^2 + 1$, then $f \circ g(-2)$ equals to

(a) 6

(b) 5

(c) -2

(d) None

5. If the universal set is

$$X = \{x : x \in N, 1 \leq x \leq 12\} \text{ and}$$

$A = \{1, 9, 10\}$, $B = \{3, 4, 6, 11, 12\}$ and $C = \{2, 5, 6\}$ are subsets of X then set $(A \cup B) \cap (A \cup C)$ is

(a) $\{3, 4, 6, 12\}$

(b) $\{1, 6, 9, 10\}$

(c) $\{2, 5, 6, 11\}$

(d) None

6. If $A = \{1, 2\}$ and $B = \{3, 4\}$. Determine the number of relations from A and B .

(a) 3

(b) 16

(c) 5

(d) 6

7. The number of proper subsets of $A \cap B$, if $A = \{1, 2, 3, 4, 5, 7, 8, 9, 10\}$ and $B = \{2, 4, 6, 7, 9\}$ is

(a) 8

(b) 15

(c) 16

(d) 64

8. Let R is the set of real number, such that the function $f : R \rightarrow R$ and $g : R \rightarrow R$ are defined by $f(x) = x^2 + 3x + 1$ and $g(x) = 2x - 3$. Find $(f \circ g)$

(a) $4x^2 + 6x + 1$

(b) $x^2 + 6x + 1$

(c) $4x^2 - 6x + 1$

(d) $x^2 - 6x + 1$

9. Identify the function from the following:

(a) $\{(1, 1), (1, 2), (1, 3)\}$

(b) $\{(1, 1), (2, 1), (2, 3)\}$

(c) $\{(1, 2), (2, 2), (3, 2), (4, 2)\}$

(d) None of these

10. If $A = \{1, 2, 3\}$ and $B = \{4, 6, 7\}$ then the relation $R = \{(2, 4), (3, 6)\}$

(a) A function

(b) A function from A and B

(c) Both (A) and (B)

(d) Not a function

11. Let R be a relation of N defined by $x + 2y = 8$. The domain of R is:

(a) $\{2, 4, 8\}$

(b) $\{2, 4, 6, 8\}$

(c) $\{2, 4, 6\}$

(d) $\{1, 2, 3, 4\}$

12. If $A = \{1, 2, 3\}$ then the relation

$R = \{(1, 1), (2, 3), (2, 2), (3, 3), (1, 2)\}$ on A is

(a) Reflexive

(b) Symmetric

(c) Transitive

(d) Equivalence

13. The domain of the function

$$f(x) = \frac{x^2 + 3x + 5}{x^2 - 5x + 4} \text{ is:}$$

- (a) \mathbb{R}
- (b) $\mathbb{R} - \{1, 4\}$
- (c) $\mathbb{R} - \{1\}$
- (d) $\{1, 4\}$

14. In the set of all straight lines on a plane which of the following is not true?

- (a) Parallel to an equivalence relation

(b) Perpendicular to is a symmetric relations

(c) Perpendicular to is an equivalence relations

(d) Parallel to is a reflexive relation

15. The domain and range of $\{(x, y) : y = x^2\}$ where $x, y \in \mathbb{R}$ is

(a) {reals, natural numbers}

(b) (reals, non-negative reals)

(c) {reals, reals}

(d) None of these

ANSWER KEY

1. (c) 2. (c) 3. (b) 4. (a) 5. (b) 6. (b) 7. (b) 8. (c) 9. (c) 10. (d)
11. (c) 12. (a) 13. (b) 14. (c) 15. (b)



UNIT-II: LIMITS AND CONTINUITY

Limits

Let $\lim_{x \rightarrow a} f(x) = l$ and $\lim_{x \rightarrow a} g(x) = m$ where l and m are finite quantities

(i) $\lim_{x \rightarrow a} \{f(x) + g(x)\} = \lim_{x \rightarrow a} f(x) + \lim_{x \rightarrow a} g(x) = l + m$

(ii) $\lim_{x \rightarrow a} \{f(x) - g(x)\} = \lim_{x \rightarrow a} f(x) - \lim_{x \rightarrow a} g(x) = l - m$

(iii) $\lim_{x \rightarrow a} \{f(x) \cdot g(x)\} = \lim_{x \rightarrow a} f(x) \cdot \lim_{x \rightarrow a} g(x) = l \cdot m$

(iv) $\lim_{x \rightarrow a} \frac{f(x)}{g(x)} = \frac{\lim_{x \rightarrow a} f(x)}{\lim_{x \rightarrow a} g(x)} = \frac{l}{m}$ if $m \neq 0$

(v) $\lim_{x \rightarrow a} c = c$ where c is constant

(vi) $\lim_{x \rightarrow a} cf(x) = c \lim_{x \rightarrow a} f(x)$

(vii) $\lim_{x \rightarrow a} F\{f(x)\} = F\left\{\lim_{x \rightarrow a} f(x)\right\} = F(l)$

◆ $\lim_{x \rightarrow 0} \frac{e^x - 1}{x} = 1$

◆ $\lim_{x \rightarrow 0} \frac{a^x - 1}{x} = \log_e a (a > 0)$

◆ $\lim_{x \rightarrow 0} \frac{\log(1+x)}{x} = 1$

◆ $\lim_{x \rightarrow \infty} \left(1 + \frac{1}{x}\right)^x = e$

◆ $\lim_{x \rightarrow a} \frac{x^n - a^n}{x - a} = na^{n-1}$

◆ $\lim_{x \rightarrow 0} \frac{(1+x)^n - 1}{x} = n$

Continuity

A function $y = f(x)$ is said to be continuous as $x = a$ if and only if

□ $f(a)$ exists i.e., f is defined at $x = a$

□ $\lim_{x \rightarrow a^-} f(x) = \lim_{x \rightarrow a^+} f(x) = f(a)$

□ $\lim_{x \rightarrow a} f(x) = f(a)$

QUESTIONS

Limits

1. Evaluate, $\lim_{x \rightarrow 3} \frac{x^2 + 4x + 3}{x^2 + 6x + 9}$ [PYQ-Jan., 2025]

(a) $\frac{2}{8}$ (b) $\frac{2}{3}$

(c) 2 (d) $\frac{1}{3}$

2. What is the value of $\lim_{y \rightarrow 2} \frac{y^2 - 4}{y - 2}$? [MTP-Sept., 24]

(a) 2 (b) 4
(c) 1 (d) 0

3. Find the value of $\lim_{x \rightarrow 4} \frac{x^2 - 2x - 8}{x^2 - 4x}$ [MTP-Sept., 2024]

(a) 0 (b) 2
(c) 8 (d) 6

4. The $\lim_{x \rightarrow 2} \frac{x^2 - 4x + 4}{x - 2} = \dots\dots\dots$ [PYQ-May, 2024]

(a) 0 (b) 1
(c) 2 (d) 3

5. $\lim_{x \rightarrow \infty} \left(\frac{1}{3} + \frac{1}{3^2} + \frac{1}{3^3} + \dots\dots\dots + \frac{1}{3^n}\right)$ is equal to:

[MTP-May, 2025]

(a) $\frac{1}{2}$ (b) $\frac{1}{3}$
(c) 2 (d) 1

Continuity

6. Let $f(x) = \frac{x^2 - 6x + 9}{x - 3}, x \neq 3, f(3) = 0$, then $f(x)$ is [MTP-May, 2025]

- (a) Continuous at $x = 3$
- (b) Discontinuous at $x = 3$
- (c) Discontinuous for all x
- (d) None of these

ANSWER KEY

1. (b) 2. (b) 3. (d) 4. (a) 5. (a) 6. (a)

HINTS & SOLUTIONS

1. (b) Substituting $x = 3$ directly into the limit expression:

$$\begin{aligned} \lim_{x \rightarrow 3} \frac{x^2 + 4x + 3}{x^2 + 6x + 9} &= \frac{3^2 + 4 \cdot 3 + 3}{3^2 + 6 \cdot 3 + 9} \\ &= \frac{9 + 12 + 3}{9 + 18 + 9} = \frac{24}{36} = \frac{2}{3} \end{aligned}$$

2. (b) $\lim_{y \rightarrow 2} \frac{y^2 - 4}{y - 2}$

$$\begin{aligned} &= \lim_{y \rightarrow 2} \frac{y^2 - 2^2}{y - 2} \\ &= \lim_{y \rightarrow 2} \frac{(y - 2)(y + 2)}{y - 2} \\ &= \lim_{y \rightarrow 2} (y + 2) = 2 + 2 = 4 \end{aligned}$$

3. (d) We have,

$$\text{Numerator: } x^2 - 2x - 8 = (x - 4)(x + 2)$$

$$\text{Denominator: } x^2 - 4x = x(x - 4)$$

Therefore,

$$\begin{aligned} \lim_{x \rightarrow 4} \frac{x^2 - 2x - 8}{x^2 - 4x} &= \lim_{x \rightarrow 4} \frac{(x - 4)(x + 2)}{x(x - 4)} \\ &= \lim_{x \rightarrow 4} \frac{x + 2}{x} = \frac{4 + 2}{4} = \frac{6}{4} = \frac{3}{2} \end{aligned}$$

4. (a) $\lim_{x \rightarrow 2} \frac{x^2 - 4x + 4}{x - 2}$

$$\begin{aligned} &= \lim_{x \rightarrow 2} \frac{x^2 - 2(2x) + 2^2}{x - 2} \\ &= \lim_{x \rightarrow 2} \frac{(x - 2)^2}{x - 2} \\ &= \lim_{x \rightarrow 2} (x - 2) \\ &= 2 - 2 = 0 \end{aligned}$$

5. (a) Given;

$$\lim_{x \rightarrow \infty} \left(\frac{1}{3} + \frac{1}{3^2} + \frac{1}{3^3} + \dots + \frac{1}{3^n} \right)$$

This is a geometric series of the form:

$$S = a + ar + ar^2 + \dots + ar^{n-1}$$

Here:

- First term $a = \frac{1}{3}$
- Common ratio $r = \frac{1}{3}$
- As $n \rightarrow \infty$, we apply the infinite geometric series formula:

$$S = \frac{a}{1 - r}, \text{ for } |r| < 1$$

Thus,

$$S = \frac{\frac{1}{3}}{1 - \frac{1}{3}} = \frac{\frac{1}{3}}{\frac{2}{3}} = \frac{1}{2}$$

6. (a) $f(x) = \frac{x^2 - 6x + 9}{x - 3}, x \neq 3$

$$\begin{aligned} \Rightarrow \lim_{x \rightarrow 3} f(x) &= \lim_{x \rightarrow 3} \frac{x^2 - 6x + 9}{x - 3} \\ &= \lim_{x \rightarrow 3} \frac{(x - 3)^2}{x - 3} \\ &= \lim_{x \rightarrow 3} (x - 3) \\ &= 3 - 3 = 0 \end{aligned}$$

Also, $f(3) = 0$ (given)

Therefore, $\lim_{x \rightarrow 3} f(x) = f(3)$



Chapter Wrap-up Test

Ready to test your knowledge?

You've got 15 questions and 20 minutes - go for it!

1. The value of $\lim_{x \rightarrow 3} \frac{3}{x-3}$ is
 (a) 0 (b) 1
 (c) $\frac{1}{2}$ (d) Does not exist
2. Evaluate: $\lim_{x \rightarrow 1} (x^3 - x^2 + 1)$
 (a) -1 (b) 1
 (c) -2 (d) None of these
3. Evaluate the left-hand and right-hand limits of the following function at

$$f(x) = \begin{cases} 5x - 4, & \text{if } 0 < x \leq 1 \\ 4x^2 - 3x, & \text{if } 1 < x < 2 \end{cases}$$
 Does $\lim_{x \rightarrow 1} f(x)$ exist? If yes, then find the value of $\lim_{x \rightarrow 1} f(x)$
 (a) 1 (b) 0
 (c) 4 (d) Does not exist
4. Evaluate the following:
 $\lim_{x \rightarrow 3} (x + 3)$
 (a) 0 (b) 3
 (c) 6 (d) Not defined
5. $\lim_{x \rightarrow 2} \frac{x^3 - 2x^2}{x^2 - 5x + 6} =$
 (a) -4 (b) $-\frac{1}{4}$
 (c) -2 (d) Not defined
6. A function is defined as follows:

$$f(x) = \begin{cases} 2x + 3, & x \leq 0 \\ 3(x + 1), & x > 0 \end{cases}$$
 Test the existence of $\lim_{x \rightarrow 0} f(x)$.
 (a) 3 (b) 4
 (c) 6 (d) Does not exist

7. Evaluate the following limit if it exist;

$$\lim_{x \rightarrow -2} \frac{\frac{1}{x} + \frac{1}{2}}{x + 2}$$

- (a) $-\frac{1}{2}$ (b) -4
 (c) -2 (d) $-\frac{1}{4}$

8. Evaluate: $\lim_{x \rightarrow 4} \frac{4x + 3}{x - 2}$

- (a) $\frac{7}{2}$ (b) $\frac{19}{2}$
 (c) 19 (d) Not defined

9. Find the following limit:

$$\lim_{x \rightarrow -1} \frac{x^{10} + x^6 + 1}{x - 1}$$

- (a) $-\frac{1}{2}$ (b) $\frac{1}{2}$
 (c) -2 (d) 2

10. Discuss the continuity of the below function at all points and choose the correct option.

$$f(x) = \begin{cases} x + 1, & \text{if } x \leq 1 \\ x^2 + 1, & \text{if } x > 1 \end{cases}$$

- (a) Continuous at $x = 0$
 (b) Continuous at $x = 1$
 (c) Continuous at all points
 (d) Discontinuous at $x = 1$

11. Evaluate the limit; $\lim_{x \rightarrow 1} \frac{x^2 - 1}{x - 1}$

- (a) 1 (b) 2
 (c) 0 (d) Does not exist

12. Find the limit; $\lim_{x \rightarrow 0} \frac{ax + b}{cx + 1}$

- (a) 0 (b) $\frac{a+b}{c}$
 (c) b (d) $\frac{b}{c}$

13. Find the limit if it exist; $\lim_{x \rightarrow 0} ((x + 1)^2 + 5)$

- (a) 0 (b) 5
(c) 7 (d) 6

14. Evaluate; $\lim_{x \rightarrow 0} \frac{\sqrt{2-x} - \sqrt{2+x}}{x}$

- (a) $\frac{1}{2}$ (b) $-\frac{1}{4}$

- (c) $\frac{1}{4}$ (d) $-\frac{1}{\sqrt{2}}$

15. Evaluate the following limit;

$$\lim_{x \rightarrow 2} \frac{x^3 - 8}{x^2 - 4}$$

- (a) 3 (b) 2
(c) 4 (d) -3

ANSWER KEY

1. (d) 2. (b) 3. (a) 4. (c) 5. (a) 6. (a) 7. (d) 8. (b) 9. (a) 10. (c)
11. (b) 12. (c) 13. (d) 14. (d) 15. (a)





Basic Concepts of Differential and Integral Calculus

Cheat Sheet by Anurag Sir

DIFFERENTIATION

- $\frac{d}{dx}(f(x)) = f'(x)$
- $\frac{d}{dx}(x^n) = nx^{n-1}$
- $\frac{d}{dx}(e^{ax}) = ae^{ax}$
- $\frac{d}{dx}(\log x) = \frac{1}{x}$
- $\frac{d}{dx}[c(\text{a constant})] = 0$
- $\frac{d}{dx}[cf(x)] = cf'(x)$

Application

- Cost function, $C(x)$: $C(x) = V(x) + F(x)$
- Average Cost (AC or C) = $\frac{C(x)}{x}$
- Average Variable Cost (AVC) = $\frac{V(x)}{x}$
- Average Fixed Cost (AFC) = $\frac{F(x)}{x}$
- Marginal Cost: $\frac{dC}{dx}$
- Revenue Function: $R(x) = P \cdot x$
- Marginal Revenue: $MR = \frac{dR}{dx}$
- Profit Function: $P(x) = R(x) - C(x)$
- Marginal Profit: $\frac{dP}{dx}$

INTEGRATION

- $\int x^n dx = \frac{x^{n+1}}{n+1} + c, n \neq -1$

- $\int dx = x$, since $\int 1 \cdot dx = \int x^0 dx = \frac{x^1}{1} = x$
- $\int e^x dx = e^x + c$
- $\int e^{ax} dx = \frac{e^{ax}}{a} + c$
- $\int \frac{1}{x} = \log x + c$
- $\int \frac{1}{ax+b} dx = \frac{1}{a} \log |ax+b| + c$
- $\int a^x dx = \frac{a^x}{\log a} + c$
- $\int c f(x) dx = c \int f(x) dx$, where c is constant
- $\int \{f(x) dx \pm g(x)\} dx = \int f(x) dx \pm \int g(x) dx$
- Definite Integral; $\int_a^b f(x) = F(b) - F(a)$

Properties of Definite Integration

- $\int_a^b f(x) dx = \int_a^b f(t) dt$ (The definite integral is independent of the variable used)
- $\int_a^b f(x) dx = -\int_b^a f(x) dx$
- $\int_a^b f(x) dx = \int_a^c f(x) dx + \int_c^b f(x) dx, a < c < b$
- $\int_0^a f(x) dx = \int_0^a f(a-x) dx$
- $\int_a^b f(x) dx = \int_a^b f(a+b-x) dx$
- $\int_{-a}^a f(x) dx = 2 \int_0^a f(x) dx$ if $f(x)$ is an even function i.e., $f(-x) = f(x)$
= 0 if $f(x)$ is an odd function i.e., $f(-x) = -f(x)$

QUESTIONS

Differential Calculus

1. If $f(x) = (x - 1)(x)(x + 1)$, then $\frac{dy}{dx} = ?$

[PYQ-June, 2024]

- (a) $3x^2 - 1$ (b) $3x^2 + 1$
 (c) $x^2 - 3$ (d) $x^2 + 3$

2. If $y = x(x - 1)(x - 2)$, then $\frac{dy}{dx}$ is:

[MTP-June, 2023]

- (a) $3x^2 - 6x + 2$ (b) $-6x^2 + 2$
 (c) $3x^2 + 2$ (d) $3x^3 + 5$

3. If a function is given by $f(x) = e^{3x}$, what is the derivative of the function? [PYQ-June, 2024]

- (a) $3e^{3x}$ (b) e^{3x}
 (c) $3xe^{3x}$ (d) $3e^{3x+3}$

4. $f(x) = x(x^2 - 2)$, then find $\frac{dy}{dx}$ [MTP-Sept., 2024]

- (a) $3x^2 - 2$ (b) $3x^2 + 2$
 (c) $x^2 - 3$ (d) x^2

5. What is the differential function of $\sqrt{x^2 + 2}$?

[PYQ-May, 2025]

- (a) $x\sqrt{x^2 + 2}dx$ (b) $\left[\frac{x}{\sqrt{x^2 + 2}}\right]dx$
 (c) $\left[\frac{x^2}{\sqrt{x^2 - 2}}\right]dx$ (d) $\left[\frac{-x}{x^2 + 2}\right]dx$

6. If $y = \sqrt{\frac{1-x}{1+x}}$, then find $(1 - x^2) \frac{dy}{dx}$

[MTP-June, 2023]

- (a) y (b) $-x$
 (c) $-y$ (d) 0

7. Find $\frac{dy}{dx}$ for $x^2y^2 + y = 0$ [PYQ-June, 2024]

- (a) $\frac{-2y^2x}{2y^2x^2 + 1}$ (b) $\frac{-2y^2x}{2yx^2 + 1}$
 (c) $\frac{-2y^2x}{2y^2x^2}$ (d) $\frac{2y^2x}{2y^2x^2}$

8. Given $x = 2t + 5, y = t^2 - 2$, then $\frac{dy}{dx}$ is calculated

as: [MTP-Sept., 2024]

- (a) t (b) $\frac{1}{t}$
 (c) $\frac{-1}{t}$ (d) None

9. Find $\frac{dy}{dx}$ where $x = \frac{e^t + e^{-t}}{2}$ and $y = \frac{e^t - e^{-t}}{2}$

[PYQ-May, 2025]

- (a) $\frac{y}{x}$ (b) $\frac{x}{y}$
 (c) $\frac{e^t}{e^{-t}}$ (d) $\frac{1}{e^t}$

10. If $x = at^2$ and $y = a(t^3 - t)$ then $\frac{dy}{dx} =$

[PYQ-Jan., 2025]

- (a) $\frac{3t^2 - t}{2t}$ (b) $\frac{3t^2 - 1}{2t}$
 (c) $\frac{3t^2 - t}{t}$ (d) $\frac{3t^2 + t}{2t}$

11. If $f(x) = x^2 - 6x + 8$ then $f'(5) - f'(8)$ is equal to [MTP-Jan., 2025]

- (a) $f'(2)$ (b) $3f'(2)$
 (c) $2f'(2)$ (d) None of these

12. If $y = x^x$, then $\frac{dy}{dx}$ is:

[MTP-June, 2022]

- (a) $x^x(2 + \log x)$ (b) $x^x \log(ex)$
 (c) $x^x \cdot \log\left(\frac{e}{x}\right)$ (d) None of these

13. If $f(x) = (x + 1)^{x+1}$, then find $f'(0)$

[PYQ-June, 2024, MTP-Sept., 2024]

- (a) 0 (b) 1
 (c) 2 (d) -1

14. The derivative of $e^x \log x$ is: [MTP-June, 2023]

- (a) $\frac{e^x}{x}(1 + x \log x)$ (b) $\frac{e^x}{x}(1 + \log x)$
 (c) $1 + \log x$ (d) None of these

15. If $x^y \times y^x = 16$, then the value of $\frac{dy}{dx}$ at $(2, 2)$ is:

[PYQ-Sept., 2024]

- (a) -1 (b) 0
(c) 2 (d) -2

16. If $y = \sqrt{x} + \frac{1}{\sqrt{x}}$ then $2x \frac{dy}{dx}$ is

[MTP-June, 2022]

- (a) $\sqrt{x} - \frac{1}{\sqrt{x}}$ (b) $\sqrt{x} + \frac{1}{\sqrt{x}}$
(c) $x - \frac{1}{x}$ (d) None of these

17. If $x = t^2$ and $y = t^3$, then $\frac{d^2y}{dx^2}$ is equal to:

[PYQ-Sept., 2024]

- (a) $\frac{3t}{2}$ (b) $\frac{3}{4t}$
(c) $\frac{3}{2t}$ (d) $\frac{3}{2}$

Application

18. Find the gradient of the curve $y = 3x^2 - 6x + 4$ at the point $(1, 2)$.

[MTP-June, 2023]

- (a) 1 (b) -1
(c) 0 (d) 2

19. The gradient of the curve $y = 2x^3 - 5x^2 - 3x$ at $x = 0$ is

[MTP-Jan., 2025]

- (a) 3 (b) -3
(c) $\frac{1}{3}$ (d) None of these

20. If $f'(x) = x - 1$, the equation of the curve $y = f(x)$ passing through the point $(1, 0)$ is given by;

[MTP-Sept., 2024]

- (a) $y = x^2 - 2x + 1$ (b) $y = \frac{x^2}{2} - x + \frac{1}{2}$
(c) $y = \frac{x^2}{2} - x + 1$ (d) None of these

21. The slope of the tangent to the curve $y = x^2 - x$ at the point where the line $y = 2$ cuts the curve in the first quadrant is:

[MTP-Sept., 2024]

- (a) 2 (b) 3
(c) -3 (d) None of these

22. The cost function for the production of x units of a commodity is given by $C(x) = 2x^3 - 15x^2 + 36x + 15$. The cost will be minimum when 'x' equal to:

[MTP-May, 2025]

- (a) 3 (b) 2
(c) 1 (d) 4

23. The marginal revenue function for a product $MR = 5 - 4x + 3x^2$. Then the total revenue function is

[PYQ-Jan., 2025]

- (a) $5x - 2x^2 + x^3$ (b) $5x + 2x^2 + x^3$
(c) $5x + 2x^2 + x^3 + 3$ (d) $5x - 2x^2 - x^3$

24. The maxima and minima of the function $y = 2x^3 - 15x^2 + 36x + 10$ occurs respectively at

[PYQ-Dec., 2022]

- (a) $x = 2$ and $x = 3$ (b) $x = 1$ and $x = 3$
(c) $x = 3$ and $x = 2$ (d) $x = 3$ and $x = 1$

Integral Calculus

25. $\int \mathcal{E}^{ax}$

[MTP-Jan., 2025]

- (a) $e^x + c$ (b) $\frac{e^{ax}}{a} + c$
(c) $\log x + c$ (d) $e^{ax} + c$

26. $\int (2x+5)^7 dx$ is equal to;

[PYQ-Jan., 2025]

- (a) $\frac{(2x+5)^7}{7}$ (b) $\frac{(2x+5)^8}{16}$
(c) $\frac{(2x^2+5x)^7}{2}$ (d) $\frac{(2x^2+5x)^7}{5}$

27. $\int (2x-3)^5 dx$

[PYQ-Dec., 2022]

- (a) $\frac{(2x-3)^6}{6} + C$ (b) $\frac{(2x-3)^6}{2} + C$
(c) $\frac{(2x-3)^6}{12} + C$ (d) $\frac{(2x-3)^6}{3} + C$

28. $\int (2x+3)^5 dx$ is

[MTP-June, 2023]

- (a) $\frac{(2x-3)^6}{6} + c$ (b) $\frac{(2x-3)^6}{2} + c$
(c) $\frac{(2x+3)^6}{12} + c$ (d) $\frac{(2x-3)^6}{5} + c$

29. Determine $f(x)$, given that $f'(x) = 12x^2 - 4x$ and $f(-3) = 17$ [PYQ-May, 2025]

- (a) $f(x) = 4x^3 - 2x^2 + 143$
 (b) $f(x) = 6x^2 - x^4 + 137$
 (c) $f(x) = 3x^4 - x^3 - 137$
 (d) $f(x) = 4x^3 - 2x^2 - 143$

30. $\int \frac{1}{x \log x} dx = ?$ [MTP-June, 2023]

- (a) $\log |x| + c$ (b) $\log |\log x| + c$
 (c) $(\log x)^2 + c$ (d) None of these

31. $\int 2^{3x} \cdot 3^{2x} \cdot 5^x dx = ?$ [MTP-Sept., 2024]

- (a) $\frac{2^{3x} \cdot 3^{2x} \cdot 5^x}{\log(720)} + c$ (b) $\frac{2^{3x} \cdot 3^{2x} \cdot 5^x}{\log(360)} + c$
 (c) $\frac{2^{3x} \cdot 3^{2x} \cdot 5^x}{\log(180)} + c$ (d) $\frac{2^{3x} \cdot 3^{2x} \cdot 5^x}{\log(90)} + c$

32. $\int \log_e x dx$ is equal to: [PYQ-Sept., 2024]

- (a) $x \log_e (ex) + c$ (b) $x \log_e \left(\frac{x}{e}\right) + c$
 (c) $x \log_e \left(\frac{e}{x}\right) + c$ (d) $\log_e \left(\frac{x}{e}\right) + c$

33. $\int xe^x dx$ is: [MTP-May, 2025]

- (a) $(x-1)e^x + C$ (b) $x \cdot e^x + C$
 (c) $\log x + x \cdot e^x + C$ (d) None of these

34. $\int x^2 e^{3x} dx$ [MTP-Sept., 2024]

- (a) $x^2 e^{3x} - 2x e^{3x} + 2e^{3x} + C$
 (b) $\frac{e^{3x}}{3} - \frac{x e^{3x}}{9} + 2e^{3x} + C$
 (c) $\frac{x^2 e^{3x}}{3} - \frac{2x e^{3x}}{9} + \frac{2}{27} e^{3x} + C$
 (d) None of these

35. Evaluate; $\int 2^x x^2 dx$ [MTP-June, 2022]

- (a) $\frac{2^x \cdot x^2}{2} - \frac{x \cdot 2^{x+1}}{(\log 2)^2} + \frac{2^{x+1}}{(\log 2)^2} + C$
 (b) $\frac{2^x \cdot x^3}{3} - \frac{x^2 \cdot 2^{x+1}}{(\log 2)^2} + \frac{2^{x+1}}{(\log 3)^2} + C$
 (c) $\frac{2^x \cdot x^2}{3} - \frac{x^3 \cdot 2^x}{3} + \frac{2^{x+1}}{(\log 2)^3} + C$
 (d) None of these

36. $\int 2^{3x} \cdot 3^{2x} \cdot 5^{2x} dx =$ [MTP-June, 2024]

- (a) $\frac{2^{3x} \cdot 3^{2x} \cdot 5^x}{\log(720)} + C$ (b) $\frac{2^{3x} \cdot 3^{2x} \cdot 5^x}{\log(360)} + C$
 (c) $\frac{2^{3x} \cdot 3^{2x} \cdot 5^x}{\log(1800)} + C$ (d) $\frac{2^{3x} \cdot 3^{2x} \cdot 5^x}{\log(90)} + C$

37. Evaluate the following integral:

$\int \frac{1}{x(x^5+1)} dx$ [MTP-Sept., 2024]

- (a) $\log \left(\frac{x^5}{x^5+1}\right) + C$ (b) $\frac{1}{5} \log \left(\frac{x^5}{x^5+1}\right) + C$
 (c) $\frac{1}{3} \log \left(\frac{x^5}{x^5+1}\right) + C$ (d) $\frac{1}{3} \log \left(\frac{x^5+1}{x^5}\right) + C$

38. The equation of the curve in the form $y = f(x)$ if the curve passes through the point $(1, 0)$ and $f'(x) = 2x - 1$, then $f(x)$ is: [MTP-June, 2023]

- (a) $y = x^2 - x$ (b) $x = y^2 - y$
 (c) $y = x^2$ (d) None of these

39. The equation of the curve which passes through the point $(1, 2)$ and has the slope $3x - 4$ and the point of (x, y) is

[MTP-Sept., 2024, MTP-Dec., 2023]

- (a) $2y = 3x^2 - 8x + 9$ (b) $y = 6x^2 - 8x + 9$
 (c) $y = x^2 - 8x + 9$ (d) $2y = 3x^2 - 8x + c$

Applications

40. $\int_2^4 (3x-2)^2 dx$ [PYQ-May, 2025]

- (a) 104 (b) 100
 (c) 10 (d) 52

41. $\int_0^2 3x^2 dx$ is [PYQ-June, 2023]

- (a) 7 (b) -8
 (c) 8 (d) -7

42. Evaluate $\int_1^4 (2x+5) dx$ and the value is

[MTP-Jan., 2025]

- (a) 3 (b) 10
 (c) 30 (d) None of these

43. $\int_1^2 \frac{2x}{1+x^2} dx$ [MTP-Sept 2024, MTP-June 2024]

- (a) $\log_e \left(\frac{5}{2}\right)$ (b) $\log_e 5 - \log_e 2 + 1$
 (c) $\log_e \left(\frac{2}{5}\right)$ (d) None of these

44. If $\int_0^1 (3x^2 + 2x + k) dx = 0$, find k
 [MTP-June, 2023]

- (a) 0 (b) -1
 (c) -2 (d) 1

45. $\int_0^1 x \cdot e^x dx$ [PYQ-Nov., 2022]

- (a) -1 (b) 1
 (c) e^1 (d) $\frac{1}{e}$

46. $\int_0^1 u(1-u)^{10} dx$ [PYQ-June, 2024]

- (a) $\frac{1}{10 \times 11}$ (b) $\frac{1}{12 \times 11}$
 (c) $\frac{1}{10 \times 9}$ (d) $\frac{1}{12 \times 13}$

ANSWER KEY

1. (a) 2. (a) 3. (a) 4. (a) 5. (b) 6. (c) 7. (b) 8. (a) 9. (b) 10. (b)
 11. (b) 12. (b) 13. (b) 14. (a) 15. (a) 16. (a) 17. (b) 18. (c) 19. (b) 20. (b)
 21. (b) 22. (a) 23. (a) 24. (a) 25. (b) 26. (b) 27. (c) 28. (c) 29. (a) 30. (b)
 31. (b) 32. (b) 33. (a) 34. (c) 35. (d) 36. (c) 37. (b) 38. (a) 39. (a) 40. (a)
 41. (c) 42. (c) 43. (a) 44. (c) 45. (b) 46. (d)

HINTS & SOLUTIONS

1. (a) $f(x) = (x-1)(x)(x+1) = x(x^2-1) = x^3-x$

Differentiate: $f'(x) = \frac{dy}{dx} = 3x^2 - 1$

2. (a) $f(x) = (x-1)(x-2) = x(x^2-3x+2)$
 $= x^3 - 3x^2 + 2x$

Differentiate: $\frac{dy}{dx} = 3x^2 - 6x + 2$

3. (a) $f(x) = e^{3x}$

$f'(x) = \frac{d}{dx}(e^{3x}) = 3e^{3x}$

4. (a) $y = f(x) = x(x^2-2) = x^3-2x$

$\frac{dy}{dx} = 3x^2 - 2$

5. (b) Let's differentiate;

$f(x) = (x^2+2)^{1/2}$

Using the chain rule:

$\frac{d}{dx} \left((x^2+2)^{1/2} \right) = \frac{1}{2} (x^2+2)^{-1/2} \cdot 2x = \frac{x}{\sqrt{x^2+2}}$

So, the differential is;

$\frac{x}{\sqrt{x^2+2}} dx$

6. (c) $y = \left(\frac{1-x}{1+x} \right)^{1/2}$

Taking logarithm:

$\log y = \frac{1}{2} [\log(1-x) - \log(1+x)]$

Differentiate both sides:

$\frac{1}{y} \frac{dy}{dx} = \frac{1}{2} \left(\frac{-1}{1-x} - \frac{1}{1+x} \right)$

$= \frac{1}{2} \left(\frac{-1-(1-x)}{(1-x)(1+x)} \right) = \frac{-1}{1-x^2}$

Therefore, $\frac{dy}{dx} = \frac{-y}{1-x^2}$

Multiply both side by $(1-x^2)$:

$(1-x^2) \frac{dy}{dx} = -y$

7. (b) Given; $x^2y^2 + y = 0$

Differentiate implicitly:

$$x^2 \cdot 2y \cdot \frac{dy}{dx} + y^2 \cdot 2x + \frac{dy}{dx} = 0$$

$$2xy^2 + (2yx^2 + 1) \frac{dy}{dx} = 0$$

$$\Rightarrow (2yx^2 + 1) \frac{dy}{dx} = -2xy^2$$

$$\Rightarrow \frac{dy}{dx} = \frac{-2xy^2}{2yx^2 + 1}$$

8. (a) We use the chain rule:

$$\frac{dy}{dx} = \frac{dy}{dt} \cdot \frac{dt}{dx}$$

Given:

$$\bullet x = 2t + 5 \Rightarrow \frac{dx}{dt} = 2$$

$$\bullet y = t^2 - 2 \Rightarrow \frac{dy}{dt} = 2t$$

$$\text{So, } \frac{dy}{dx} = \frac{dy/dt}{dx/dt} = \frac{2t}{2} = t$$

9. (b) We are given:

$$\bullet x = \frac{e^t + e^{-t}}{2}$$

$$\bullet y = \frac{e^t - e^{-t}}{2}$$

Differentiate both:

$$\bullet \frac{dy}{dt} = \frac{d}{dt} \left(\frac{e^t - e^{-t}}{2} \right) = \frac{e^t + e^{-t}}{2} = x$$

$$\bullet \frac{dx}{dt} = \frac{d}{dt} \left(\frac{e^t + e^{-t}}{2} \right) = \frac{e^t - e^{-t}}{2} = y$$

$$\text{Therefore, } \frac{dy}{dx} = \frac{dy/dt}{dx/dt} = \frac{x}{y}$$

10. (b) Given, $x = at^2$ and $y = a(t^3 - t)$,

$$\frac{dx}{dt} = 2at, \frac{dy}{dt} = a(3t^2 - 1)$$

$$\text{So, } \frac{dy}{dx} = \frac{\frac{dy}{dt}}{\frac{dx}{dt}} = \frac{a(3t^2 - 1)}{2at} = \frac{3t^2 - 1}{2t}$$

11. (b) Given: $f(x) = x^2 - 6x + 8$

$$f'(x) = 2x - 6$$

Calculate $f'(5)$ and $f'(8)$:

$$f'(5) = 2(5) - 6 = 10 - 6 = 4$$

$$f'(8) = 2(8) - 6 = 16 - 6 = 10$$

$$\text{Now, } 3 \times f'(2) = 3 \times (-2) = -6$$

$$\text{So, } f'(5) - f'(8) = 3 \times f'(2)$$

12. (b) Given, $y = x^x$

Taking log on both sides, we get

$$\log y = x \log x$$

On differentiating both sides, we get

$$\frac{1}{y} \frac{dy}{dx} = x \cdot \frac{1}{x} + \log x$$

$$\Rightarrow \frac{dy}{dx} = y(1 + \log x)$$

$$\Rightarrow \frac{dy}{dx} = x^x(1 + \log x)$$

$$\Rightarrow \frac{dy}{dx} = x^x(\log e + \log x)$$

$$\Rightarrow \frac{dy}{dx} = x^x \log(ex)$$

13. (b) $\log f(x) = (x + 1) \log(x + 1)$

Differentiate both sides:

$$\frac{1}{f(x)} f'(x) = \log(x+1) + (x+1) \cdot \frac{1}{x+1} = \log(x+1) + 1$$

$$f'(x) = f(x)[1 + \log(x + 1)]$$

Now plug in $x = 0$:

$$f(0) = (0 + 1)^{0+1} = 1$$

$$f'(0) = 1 \cdot [1 + \log(1)] = 1 \cdot (1 + 0) = 1$$

14. (a) $\frac{d}{dx}(e^x \log x) = e^x \cdot \frac{1}{x} + \log x \cdot e^x$

$$= e^x \left(\frac{1}{x} + \log x \right)$$

$$= \frac{e^x}{x} (1 + x \log x)$$

15. (a) Given, $x^y \times y^x = 16$

Taking log on both sides, we get

$$\log(x^y \cdot y^x) = \log 16$$

$$y \log x + x \log y = \log 16$$

Differentiate w.r.t x :

$$y \cdot \frac{1}{x} + \log x \cdot \frac{dy}{dx} + \log y + x \cdot \frac{1}{y} \frac{dy}{dx} = 0$$

Substitute $x = 2, y = 2$:

$$\frac{2}{2} + \log 2 \cdot \frac{dy}{dx} + \log 2 + \frac{2}{2} \frac{dy}{dx} = 0$$

$$1 + \log 2 \frac{dy}{dx} + \log 2 + \frac{dy}{dx} = 0$$

$$1 + \log 2 + \frac{dy}{dx} (\log 2 + 1) = 0$$

$$\frac{dy}{dx} (\log 2 + 1) = -(1 + \log 2)$$

$$\frac{dy}{dx} = \frac{-(1 + \log 2)}{(\log 2 + 1)} = -1$$

16. (a) $y = \sqrt{x} + \frac{1}{\sqrt{x}}$

$$\Rightarrow y = x^{\frac{1}{2}} + x^{-\frac{1}{2}}$$

On differentiating w.r.t x , we get

$$\frac{dy}{dx} = \frac{1}{2} \cdot x^{\frac{1}{2}-1} - \frac{1}{2} x^{-\frac{1}{2}-1}$$

$$\Rightarrow \frac{dy}{dx} = \frac{1}{2} \cdot x^{-\frac{1}{2}} - \frac{1}{2} x^{-\frac{3}{2}}$$

$$\Rightarrow \frac{dy}{dx} = \frac{1}{2\sqrt{x}} - \frac{1}{2x^{\frac{3}{2}}}$$

$$\Rightarrow 2x \frac{dy}{dx} = \frac{2x}{2\sqrt{x}} - \frac{2x}{2x^{\frac{3}{2}}}$$

$$\Rightarrow 2x \frac{dy}{dx} = \sqrt{x} - \frac{1}{\sqrt{x}}$$

17. (b) Give, $x = t^2, y = t^3$

Differentiate x and y w.r.t t , we get

$$\frac{dy}{dt} = 3t^2, \frac{dx}{dt} = 2t$$

$$\frac{dy}{dx} = \frac{dy/dt}{dx/dt} = \frac{3t^2}{2t} = \frac{3t}{2}$$

Now, differentiate $\frac{dy}{dx}$ with respect to x :

$$\frac{d}{dx} \left(\frac{dy}{dx} \right) = \frac{d}{dx} \left(\frac{3t}{2} \right)$$

$$\text{So, } \frac{d^2y}{dx^2} = \frac{1}{2t} \frac{d}{dt} \left(\frac{3t}{2} \right) = \frac{1}{2t} \cdot \frac{3}{2} = \frac{3}{4t}$$

18. (c) $\frac{dy}{dx} = 6x - 6$

At $x = 1$

$$\frac{dy}{dx} = 6(1) - 6 = 0$$

19. (b) Given; $y = 2x^3 - 5x^2 - 3x$

Therefore, the gradient of the curve is given by;

$$y' = \frac{dy}{dx} = 6x^2 - 10x - 3$$

At $x = 0$,

$$y'(0) = -3$$

20. (b) We are given:

$$f'(x) = x - 1$$

To find $f(x)$, integrate:

$$f(x) = \int (x - 1) dx = \frac{x^2}{2} - x + c$$

Use the point $(1, 0)$ to find C :

$$0 = \frac{1^2}{2} - 1 + C$$

$$0 = \frac{1}{2} - 1 + C$$

$$0 = -\frac{1}{2} + C$$

$$C = \frac{1}{2}$$

So, the required function is:

$$y = \frac{x^2}{2} - x + \frac{1}{2}$$

21. (b) Given, $y = x^2 - x$

At $y = 2$

$$2 = x^2 - x \Rightarrow x^2 - x - 2 = 0$$

$$(x - 2)(x + 1) = 0 \Rightarrow x = 2 \text{ or } x = -1$$

Since first quadrant $\Rightarrow x = 2$

$$\text{Derivative; } \frac{dy}{dx} = 2x - 1$$

At $x = 2$

$$\frac{dy}{dx} = 2(2) - 1 = 3$$

22. (a) The cost function is:

$$C(x) = 2x^3 - 15x^2 + 36x + 15$$

$$C'(x) = 6x^2 - 30x + 36$$

Put $C'(x) = 0$, we get

$$6x^2 - 30x + 36 = 0$$

$$\Rightarrow x^2 - 5x + 6 = 0$$

$$\Rightarrow (x - 2)(x - 3) = 0$$

So, critical points are $x = 2$ and $x = 3$

$$\text{Now, } C''(x) = 12x - 30$$

At $x = 2$:

$$C''(2) = 12(2) - 30 = -6 \text{ (Negative } \Rightarrow \text{Maximum)}$$

At $x = 3$:

$$C''(3) = 12(3) - 30 = 6 \text{ (Positive } \Rightarrow \text{Minimum)}$$

Therefore, the cost will be minimum when $x = 3$

- 23.** (a) Given marginal revenue function:

$$MR = 5 - 4x + 3x^2$$

Total revenue $R(x)$ is the integral of MR :

$$\begin{aligned} R(x) &= \int (5 - 4x + 3x^2) dx \\ &= 5x - 2x^2 + x^3 + C \end{aligned}$$

Since total revenue usually assumes $R(0) = 0$ i.e., $C = 0$

Therefore, the total revenue function is $5x - 2x^2 + x^3$.

- 24.** (a) Given: $y = 2x^3 - 15x^2 + 36x + 10$

On differentiating y wrt x , we get

$$\frac{dy}{dx} = 6x^2 - 30x + 36 \quad \dots(i)$$

$$\text{and } \frac{d^2y}{dx^2} = 12x - 30 \quad \dots(ii)$$

Now, substitute $\frac{dy}{dx} = 0$

$$\Rightarrow 6x^2 - 30x + 36 = 0$$

$$\Rightarrow 6(x^2 - 5x + 6) = 0$$

$$\Rightarrow x^2 - 5x + 6 = 0$$

$$\Rightarrow x^2 - 3x - 2x + 6 = 0$$

$$\Rightarrow x(x - 3) - 2(x - 3) = 0$$

$$\Rightarrow (x - 3)(x - 2) = 0$$

$$\Rightarrow x = 3 \text{ and } x = 2$$

Now, put $x = 3$ in (ii), we get

$$\frac{d^2y}{dx^2} = 36 - 30 = 6 > 0, \text{ attaining minima}$$

Now, put $x = 2$ in (ii), we get

$$\frac{d^2y}{dx^2} = 24 - 30 = -6 < 0, \text{ attaining maxima}$$

Therefore, the given function attains maxima at $x = 2$ and minima at $x = 3$.

Hence, the correct option is (a).

25. (b) $\int e^{ax} dx = \frac{1}{a} e^{ax} + c$

26. (b) Given, $\int (2x + 5)^7 dx$

Use substitution formula:

$$\int (ax + b)^n dx = \frac{(ax + b)^{n+1}}{a(n+1)} + C$$

Here, $a = 2, n = 7$

$$= \frac{(2x + 5)^8}{2 \times 8} + C = \frac{(2x + 5)^8}{16} + C$$

27. (c) To evaluate; $\int (2x - 3)^5 dx$

$$\text{Using, } \int x^n = \frac{x^{n+1}}{n+1} + c$$

Thus,

$$\int (2x - 3)^5 = \frac{(2x - 3)^{5+1}}{(5+1) \cdot \frac{d}{dx}(2x)} + c$$

$$= \frac{(2x - 3)^6}{6 \times 2} + C$$

$$= \frac{(2x - 3)^6}{12} + C$$

Where, c is constant of integration.

Hence, the correct option is (c).

- 28.** (c) Using the standard formula:

$$\int (ax + b)^n dx = \frac{(ax + b)^{n+1}}{a(n+1)} + c$$

Here; $a = 2, n = 5$

$$= \frac{(2x + 3)^6}{2 \times 6} + c = \frac{(2x + 3)^6}{12} + c$$

29. (a) $f(x) = \int f'(x) dx$

$$= \int (12x^2 - 4x) dx$$

$$f(x) = 4x^3 - 2x^2 + C$$

$$f(-3) = 4(-3)^3 - 2(-3)^2 + C$$

$$17 = -108 - 18 + C$$

$$C = 143$$

$$\Rightarrow f(x) = 4x^3 - 2x^2 + 143$$

$$30. (b) \int \frac{1}{x \log x} dx = \log |\log x| + c$$

$$31. (b) \int (2^3)^x \cdot (3^2)^x \cdot 5^x dx$$

$$= \int (8 \cdot 9 \cdot 5)^x dx = \int 360^x dx$$

$$\text{Integrate; } \int 360^x dx = \frac{360^x}{\log 360} + C$$

$$= \frac{2^{3x} \cdot 3^{2x} \cdot 5^x}{\log(360)} + C$$

32. (b) Using integration by parts,

$$\int \log_e x \cdot (1) dx$$

$$= \log_e x \int dx - \int \left[\frac{d}{dx} \log_e x \int dx \right] dx$$

$$= \log_e x \cdot x - \int \frac{1}{x} \cdot x dx$$

$$= x \log_e x - x + C$$

$$= x(\log_e x - 1) + C$$

$$= x(\log_e x - \log_e e) + C$$

$$= x \log_e \left(\frac{x}{e} \right) + C$$

33. (a) Using integration by parts, we get

$$\int x e^x dx = x e^x - \int e^x dx$$

$$= x e^x - e^x + C = (x - 1) e^x + C$$

$$= (x - 1) e^x + C$$

34. (c)

$$\bullet u = x^2, dv = e^{3x} dx$$

Then;

$$\bullet du = 2x dx, v = \frac{1}{3} e^{3x}$$

$$\int x^2 e^{3x} dx = x^2 \cdot \frac{1}{3} e^{3x} - \int 2x \cdot \frac{1}{3} e^{3x} dx$$

$$= \frac{x^2}{3} e^{3x} - \frac{2}{3} \int x e^{3x} dx$$

Now compute, $\int x e^{3x} dx$

Let $u = x, dv = e^{3x} dx$

Then, $du = dx, v = \frac{1}{3} e^{3x}$

$$\int x e^{3x} dx = x \cdot \frac{1}{3} e^{3x} - \int \frac{1}{3} e^{3x} dx = \frac{x}{3} e^{3x} - \frac{1}{9} e^{3x}$$

Now substitute back:

$$\int x^2 e^{3x} dx = \frac{x^2}{3} e^{3x} - \frac{2}{3} \left(\frac{x}{3} e^{3x} - \frac{1}{9} e^{3x} \right)$$

$$= \frac{x^2}{3} e^{3x} - \frac{2x}{9} e^{3x} + \frac{2}{27} e^{3x} + C$$

35. (d) $\int 2^x x^2 dx$

According to the rule,

Here, $u = x^2$ and $v = 2^x$

$$\Rightarrow \int 2^x x^2 dx$$

$$\Rightarrow x^2 \int 2^x dx - \int \left[\frac{d}{dx} (x^2) \cdot \int 2^x dx \right] dx$$

$$\Rightarrow \frac{x^2 2^x}{\log 2} - \int \left[2x \cdot \frac{2^x}{\log 2} \right] dx$$

$$\Rightarrow \frac{x^2 2^x}{\log 2} - \frac{2}{\log 2} \int x \cdot 2^x dx$$

$$\Rightarrow \frac{x^2 2^x}{\log 2} - \frac{2}{\log 2} \left[\frac{x \cdot 2^x}{\log 2} - \int \frac{2^x}{(\log 2)} dx \right]$$

$$\Rightarrow \frac{x^2 2^x}{\log 2} - \frac{2}{\log 2} \left[\frac{x \cdot 2^x}{\log 2} - \frac{2^x}{(\log 2)^2} \right] + c$$

$$\Rightarrow \frac{x^2 2^x}{\log 2} - \frac{x \cdot 2^{x+1}}{(\log 2)^2} + \frac{2^{x+1}}{(\log 2)^3} + c$$

36. (c) $\int 2^{3x} \cdot 3^{2x} \cdot 5^{2x} dx$

$$= \int (2^3)^x \cdot (3^2)^x \cdot (5^2)^x dx$$

$$= \int 8^x \cdot 9^x \cdot 25^x dx$$

$$= \int (8 \times 9 \times 25)^x dx$$

$$= \int (8 \times 9 \times 25)^x dx$$

$$= \frac{(1800)^x}{\log 1800} + c$$

$$= \frac{2^{3x} \cdot 3^{2x} \cdot 5^{2x}}{\log 1800} + c$$

37. (b) Let $x^5 = t$

$$\text{Then } 5x^4 dx = dt \Rightarrow x^4 dx = \frac{dt}{5}$$

Now, rewrite the integral:

$$I = \int \frac{x^4}{x(x^5+1)} dx = \int \frac{1}{x^5(x^5+1)} x^4 dx$$

Substitute;

$$= \int \frac{1}{t(t+1)} \cdot \frac{dt}{5} = \frac{1}{5} \int \frac{(t+1)-t}{t(t+1)} dt$$

$$= \frac{1}{5} \int \left(\frac{1}{t} - \frac{1}{t+1} \right) dt$$

Now, integrate:

$$= \frac{1}{5} [\log|t| - \log|t+1|] + C = \frac{1}{5} \log \left| \frac{t}{t+1} \right| + C$$

Back-substitute $t = x^5$:

$$\frac{1}{5} \log \left(\frac{x^5}{x^5+1} \right) + C$$

38. (a) $f(x) = \int (2x-1) dx = x^2 - x + k$

Using point (1, 0):

$$0 = 1^2 - 1 + k \Rightarrow k = 0$$

$$\text{So, } y = x^2 - x$$

39. (a) Given slope $\frac{dy}{dx} = 3x - 4$

$$\text{Integrate; } y = \frac{3x^2}{2} - 4x + c$$

$$\text{Multiple by 2; } 2y = 3x^2 - 8x + 2c$$

$$\text{Use point (1, 2); } 4 = 3 - 8 + 2c \Rightarrow 2c = 9$$

$$\text{So, } 2y = 3x^2 - 8x + 9$$

40. (a) Using the identity:

$$\int (ax+b)^n dx = \frac{(ax+b)^{n+1}}{(n+1) \cdot a}$$

Therefore,

$$\int_2^4 (3x-2)^2 dx$$

$$= \left[\frac{(3x-2)^3}{3 \cdot 3} \right]_2^4 = \frac{1}{9} [10^3 - 4^3]$$

$$= \frac{1}{9} (100 - 64) = \frac{936}{9} = 104$$

41. (c) $\int_0^2 3x^2 dx = 3 \int_0^2 x^2 dx$

$$= 3 \left[\frac{x^3}{3} \right]_0^2 = 2^3 - 0^3 = 8$$

42. (c) $\int_1^4 (2x+5) dx = [x^2 + 5x]_1^4$
 $= (16 + 20) - (1 + 5) = 36 - 6 = 30$

43. (a) We know,

$$\frac{d}{dx} [1+x^2] = 2x$$

$$\Rightarrow \int \frac{2x}{1+x^2} dx = \ln|1+x^2| + C$$

So, evaluating the definite integral:

$$\int_1^2 \frac{2x}{1+x^2} dx = [\ln(1+x^2)]_1^2$$

$$= \ln(1+4) - \ln(1+1) = \ln(5) - \ln(2) = \ln\left(\frac{5}{2}\right)$$

44. (c) $\int_0^1 (3x^2 + 2x + k) dx = [x^3 + x^2 + kx]_0^1$

$$1 + 1 + k = 0$$

$$2 + k = 0 \Rightarrow k = -2$$

45. (b) $\int_0^1 x \cdot e^x dx$

Apply 'LAE' rule, we get

$$\left[x \cdot e^x \right]_0^1 - \int_0^1 1 \cdot e^x dx$$

$$= (1 \cdot e^1 - 0) - \left[e^x \right]_0^1$$

$$= e^1 - (e^1 - e^0)$$

$$= e^1 - e^1 + 1 = 1$$

46. (d) $\int_0^1 u(1-u)^{10} du = \int_0^1 (1-u)u^{10} du$

$$= \int_0^1 u^{10} - u^{11} du$$

Now integrate term by term:

$$= \left[\frac{u^{11}}{11} \right]_0^1 - \left[\frac{u^{12}}{12} \right]_0^1 = \left(\frac{1}{11} - 0 \right) - \left(\frac{1}{12} - 0 \right)$$

$$= \frac{1}{11} - \frac{1}{12} = \frac{12-11}{132} = \frac{1}{132}$$

$$= \frac{1}{11 \times 12}$$

Chapter Wrap-up Test

Ready to test your knowledge?

You've got 15 questions and 20 minutes - go for it!

1. If $y = x^{\frac{2}{3}}$, then $\frac{dy}{dx}$ is

(a) $\frac{2}{3}x^{-\frac{1}{3}}$ (b) $\frac{3}{5}x^{\frac{5}{3}}$

(c) $\frac{-3}{5}x^{\frac{5}{3}}$ (d) None

2. Given $f(x) = 4x^3 + 3x^2 - 2x + 5$ and

$\int f(x) dx$ is

(a) $x^4 + x^3 - x^2 + 5x$

(b) $x^4 + x^3 - x^2 + 5$

(c) $12x^2 + 6x - 2x^2$

(d) None of these

3. The cost function of a company

$C(x) = 100x - 2x^2 + 120$, $0 \leq x \leq 100$
and the revenue function $R(x) = 500 - x$,
then the profit function is

(a) $2x^2 - 101x + 380$

(b) $2x^2 - 100x + 620$

(c) $x^2 + 101x + 380$

(d) None of these

4. If $y = x^3 + 4x + \log x$, then find $\frac{dy}{dx}$

(a) $3x^2 + 4^x + \frac{1}{x}$

(b) $3x^2 + 4^x \log_e 4 + \frac{1}{x}$

(c) $3x^2 + 4^x \log_e x + \frac{1}{x}$

(d) $3x^3 + 4^x \log_e 4 + \frac{1}{x}$

5. If $x^y = e^{x-y}$, then $\frac{dy}{dx}$ is

(a) $\frac{\log x}{(1 - \log x)^2}$ (b) $\frac{\log x}{(1 + \log x)^2}$

(c) $\frac{\log x}{(1 - \log x)}$ (d) $\frac{\log x}{(1 + \log x)}$

6. If $x^2 + y^2 - 2x = 0$, then $\frac{dy}{dx}$ is

(a) $\frac{1-x}{y}$ (b) $\frac{1+x}{y}$

(c) $\frac{x-1}{y}$ (d) None

7. If $y = e^{\sqrt{2x}}$ then $\frac{dy}{dx}$ is equal to

(a) $\frac{e^{\sqrt{2x}}}{\sqrt{2x}}$ (b) $e^{\sqrt{2x}}$

(c) $\frac{e^{\sqrt{2x}}}{2\sqrt{x}}$ (d) None of these

8. $f(x) = \frac{x^2}{e^x}$ then $f'(1)$ is equal to

(a) $-\frac{1}{e}$ (b) $\frac{1}{e}$

(c) e (d) None of these

9. The total cost of producing x units of a certain product is $C(x) = \frac{1}{3}x^3 - 18x^2 + 160x$, then find the number of units of x that should be produced in order to minimize the marginal cost.

(a) 18 (b) 16

(c) 8 (d) 2

10. Integrate w.r.t x ,

$x^{-1}[ax^3 + bx^2 + cx + d]$

(a) $\frac{1}{3}ax^3 + \frac{1}{2}bx^2 + cx + d \log x + k$

(b) $3ax^3 + 2bx^2 + cx + d \log x + k$

(c) $2ax + b - dx^{-2} + k$

(d) None

11. $\int (1 - 3x)(1 + x) dx$ is equal to

- (a) $x - x^2 - x^3$
- (b) $x^3 - x^2 + x$
- (c) $x - x^2 - x^3 + k$
- (d) None of these

12. If $y = \frac{e^x + 1}{e^x - 1}$, then $\frac{dy}{dx}$ is equal to

- (a) $\frac{-2e^x}{(e^x - 1)^2}$
- (b) $\frac{2e^x}{(e^x - 1)^2}$
- (c) $\frac{-2}{(e^x - 1)^2}$
- (d) None of these

13. $\int_0^1 x \cdot e^x dx$

- (a) -1
- (b) 1
- (c) e^1
- (d) $\frac{1}{e}$

14. The gradient of the curve

$y = 2x^3 - 3x^2 - 12x + 8$ at $x = 0$ is

- (a) -12
- (b) 12
- (c) 0
- (d) None of these

15. The total cost function of a company is given by $C(x) = -2x^2 + 500x$. Find the marginal cost when $x = 20$.

- (a) 580
- (b) 500
- (c) 400
- (d) 420

ANSWER KEY

1. (a) 2. (b) 3. (a) 4. (b) 5. (b) 6. (a) 7. (a) 8. (b) 9. (a) 10. (a)
11. (c) 12. (a) 13. (b) 14. (a) 15. (d)





Number Series, Coding & Decoding & Odd Man Out

Cheat Sheet by Anurag Sir

DIFFERENT TYPES OF NUMBER SERIES

1. Perfect Square Series: This series is based on the square of a number which is in the same order.

Example; 400, 441, 484, 529, 576,.....

i.e., $20^2, 21^2, 22^2, 23^2, 24^2, \dots$

2. Perfect Cube Series: This series is based on the cube of a number which is in the same order.

Example; 1000, 1331, 1728, 2197,.....

i.e., $10^3, 11^3, 12^3, 13^3, \dots$

3. Difference Series: Here, the difference between two consecutive terms 'or' difference between alternate terms are equal 'or' difference makes another series.

Example; 7, 12, 17, 22,.....

i.e., the difference between two consecutive terms is equal that is 5.

4. Prime Number Series: Series of Prime numbers.

Example; 2, 3, 5, 7, 11, 13, 17,

5. Arithmetic Progression/Series: Here, arrangement of numbers makes an Arithmetic Progression.

Example; 100, 95, 90, 85,.....

i.e., the difference between two consecutive terms is equal.

6. Geometric Series: Here, arrangement of numbers makes a Geometric Progression.

Example; 4, 12, 36, 108,.....

i.e., the ratio between two consecutive terms is equal.

7. Alphabet Series: Series is related to the positions of English Alphabets.

1	2	3	4	5	6	7	8	9	10	11	12	13	14	15	16	17	18	19	20	21	22	23	24	25	26
A	B	C	D	E	F	G	H	I	J	K	L	M	N	O	P	Q	R	S	T	U	V	W	X	Y	Z
26	25	24	23	22	21	20	19	18	17	16	15	14	13	12	11	10	9	8	7	6	5	4	3	2	1

8. Letter Series: Series of small letters which follow a specific pattern.

Coding-Decoding

1. Letter Coding: Each letter is replaced with a fixed position shift.

Example: WORD = XPSE (Each letter +1)

2. Number Coding: Words are coded by assigning numerical values or patterns.

Example: APPLE = $1+16+16+12+5 = 50$

3. Substitution Coding: Words are replaced with other words.

Example: "If 'apple' is coded as 'banana,'" then 'banana' stands for 'apple'.

Odd One Out

1. Number Based: Find the number which doesn't follow the pattern.

Example: 11, 13, 17, 19, 21 → 21 is odd one (not prime)

2. Word Based: Identify the word that doesn't belong to a common category.

Example: Dog, Cat, Lion, Mango → Mango (not an animal)

3. Letter Based: Odd one based on letter series, position or symmetry.

Example: A, C, E, G, K → K (gap of 4, not 2)

QUESTIONS

Series

1. Find the next number in the series;
2, 5, 11, 23, 47,..... [PYQ-Sept., 2024]
(a) 84 (b) 95
(c) 98 (d) 105
2. In the following series, which number will replace the question mark 23, 29, 31, 37, 41, 43, ?
[MTP-June, 2024]
(a) 45 (b) 54
(c) 47 (d) 49
3. The number in place of question mark in: 7, 26, 63, 124, 215, ?, 511 is [PYQ-June, 2023]
(a) 342 (b) 343
(c) 441 (d) 421
4. Find missing term of the series 2, 3, 3, 5, 10, 13, ?, 43, 172, 177 [MTP-June, 2022]
(a) 23 (b) 38
(c) 39 (d) 40
5. 2, 3, 8,, 3968 [PYQ-Dec., 2023]
(a) 65 (b) 63
(c) 70 (d) 80
6. Find next term of the series; 1, 3, 4, 8, 15, 27, ?
[MTP-Sept. 2024]
(a) 37 (b) 44
(c) 50 (d) 55
7. Find the next term of the series; 1, 5, 14, 30, 55, 91, ? [PYQ-Dec., 2019, MTP-Sept., 2024]
(a) 130 (b) 140
(c) 150 (d) 160
8. Find the missing value in the series; 51, 52, 60, 87, 151,, 492. [PYQ-June, 2024]
(a) 195 (b) 276
(c) 317 (d) 420
9. AZ, GT, MN,, YB, EV. The value at blank space (.....) will be; [PYQ-Sept., 2024]
(a) JH (b) SH
(c) SK (d) TS

10. Find the missing term
P 3 C; R 5 F; T 8 I; V 12 L; _____?
[PYQ-Jan, 2021]
(a) Y17O (b) X17M
(c) X17O (d) X16O
11. Find missing term of the letter series A, CD, GHI, ?, UVWXY. [MTP-June, 2022]
(a) LMNO (b) MNO
(c) MNOP (d) NOPQ
12. What comes next in the series; FMAMJJASON?
[PYQ-June, 2024]
(a) DBM (b) DJM
(c) DJF (d) DDJ

Coding-Decoding

13. In a certain code language. 'CLOCK' is coded as '75276' and 'EARTH' is coded as '83491', then 'COAT' is coded as [PYQ-Jan., 2025]
(a) 7239 (b) 7329
(c) 7932 (d) 7529
14. If TAP is coded as SZO, then how is FRIEND coded in same language? [PYQ-Sept., 2024]
(a) CMDHQE (b) QEDHCM
(c) EQIENE (d) EQHDMC
15. In certain system of code STATEMENT is coded as TNEMETATS, then how the word can POLITICAL be coded? [PYQ-Dec., 2023]
(a) LACITILOP (b) LACTILIOP
(c) OPILITACL (d) LACATILOP
16. In a certain code INACTIVE is written as VITCANIE. How is COMPUTER written in the same code? [PYQ-June, 2024]
(a) PMOCRETU (b) ETUPMOCR
(c) UTEPMOCR (d) MOCPETUR
17. In a certain language SIKKIM written as THLJLL, then TRAINING coded as [PYQ-Dec., 2023]
(a) SQBHOHOH (b) UQBHOHOF
(c) UQBJOHOH (d) UQBJOHOM
18. In a certain code TEACHER is written as VGCEJGT. How is CHILDREN written in that code? [PYQ-June, 2024]
(a) EJKNEGTP (b) EGKNFITP
(c) EJKNFGTO (d) EJKNFTGP

19. In a certain code language, if TOUR is written as 1234, CLEAR is written as 56784 and SPARE is written as 90847. Find the code for TEARS.

[PYQ-Dec., 2022]

- (a) 17847 (b) 14847
(c) 15247 (d) 17849

20. In a certain code, RIPPLE is written as 613382 and LIFE is written as 8192. How is PILLER written in that code?

[PYQ-Sept., 2024]

- (a) 318826 (b) 318286
(c) 618826 (d) 338816

21. In a certain code, TEACHER is written as VGCEJGT. How is CHILDREN written in that code?

[MTP-Jan., 2025]

- (a) EJKNEGTP (b) EGKNEITP
(c) EJKNFGTO (d) EJKNFTGP

22. In a certain code "CH4IR" is written as "GL8MV". How is "1N5T4GR4M" is written in that code?

[PYQ-May, 2025]

- (a) 4HFID8E8N
(b) 4P8W7JU80
(c) 5R9X8KV8Q
(d) 5KF2EGR4

23. If HEALTH is coded as GSKZDG, then how NORTH be written in that code?

[MTP-Jan., 2025]

- (a) OPSUI (b) GSQNM
(c) FRPML (d) IUSPO

24. In a certain language, 'MENTION' is written as 'NFOUJPO', the code of 'MYSTIFY' is

[PYQ-Jan., 2025]

- (a) NEOFTJT (b) NZTUJGZ
(c) LNEITNO (d) OERESTN

25. In certain language. PEAR is coded as 7519 and TOIL is coded as 2693, how DOCTOR be written in that code?

[PYQ-Dec., 2023]

- (a) 463293 (b) 463239
(c) 463269 (d) 463296

26. Identify the next number in the following series; 2, 8, 26, 62, 122, 212,.....

[PYQ-May, 2025]

- (a) 332 (b) 338
(c) 356 (d) 362

27. If HONEY is coded as JQPGA, which word is coded as VCTIGVU?

[MTP-Jan., 2025]

- (a) CARPETS (b) TRAPETS
(c) TARGETS (d) UMBRELU

28. In a certain mode, '493' means 'Friendship difficult challenge', '961' means 'Struggle difficult Exam' and '178' means 'Exam believable subject', then which digit is used for 'believable'?

[MTP-June, 2024]

- (a) 7 or 8 (b) 7 or 9
(c) 8 (d) 8 or 1

Odd One Out

29. 16, 25, 36, 72, 144, 196, 225, find the odd one out.

[PYQ-Dec., 2023]

- (a) 36 (b) 72
(c) 196 (d) 225

30. Out of the following; 41, 43, 47, 53, 61, 71, 83, 95, the odd man out shall be;

[PYQ-June, 2023]

- (a) 95 (b) 81
(c) 71 (d) 53

31. Find wrong number of the series;

1, 5, 5, 9, 7, 11, 11, 15, 12, 17 [MTP-June, 2022]

- (a) 11 (b) 12
(c) 17 (d) 15

32. Find the odd man out of the following series;

7, 23, 47, 119, 171, 287 [PYQ-Sept., 2024]

- (a) 119 (b) 171
(c) 287 (d) 7

33. Find the odd man out in the following series; 190, 145, 136, 352, 460, 324, 631, 244.

[PYQ-June, 2023]

- (a) 136 (b) 244
(c) 460 (d) 324

34. Which of the following is odd one?

[MTP-Jan., 2025]

- (a) CEHL (b) KMPT
(c) OQTX (d) NPSV

35. In a series of letters, which one is the odd one out: BDFH, JLNP, RTVX, ZBDE?

[PYQ-June, 2024]

- (a) BDFH (b) JLNP
(c) TVX (d) ZBDE

ANSWER KEY

- | | | | | | | | | | |
|---------|---------|---------|---------|---------|---------|---------|---------|---------|---------|
| 1. (b) | 2. (c) | 3. (a) | 4. (c) | 5. (b) | 6. (c) | 7. (b) | 8. (b) | 9. (b) | 10. (c) |
| 11. (c) | 12. (c) | 13. (a) | 14. (d) | 15. (a) | 16. (b) | 17. (b) | 18. (d) | 19. (d) | 20. (a) |
| 21. (d) | 22. (c) | 23. (b) | 24. (b) | 25. (c) | 26. (b) | 27. (c) | 28. (a) | 29. (b) | 30. (a) |
| 31. (b) | 32. (b) | 33. (d) | 34. (d) | 35. (d) | | | | | |

HINTS & SOLUTIONS

1. (b) Given Series; 2, 5, 11, 23, 47,.....

On analysing the pattern, we get

$$2 + 3 = 5$$

$$5 + 6 = 11$$

$$11 + 12 = 23$$

$$23 + 24 = 47$$

$$47 + 48 = 95$$

Therefore, the next term is 95.

2. (c) Given series; 23, 29, 31, 37, 41, 43, ?

We analyse that,

The given series is the series of prime numbers.
Therefore, the next term = 47.

3. (a) Given series; 7, 26, 63, 124, 215, ?, 511

Here, the pattern followed is;

$$7 = 2^3 - 1$$

$$26 = 3^3 - 1$$

$$63 = 4^3 - 1$$

$$124 = 5^3 - 1$$

$$215 = 6^3 - 1$$

$$\mathbf{342 = 7^3 - 1}$$

$$511 = 8^3 - 1$$

Therefore, 342 is the required missing term.

4. (c) Given series 2,3,3, 5,10,13, ?, 43,172,177

Here, the pattern follows is:

$$2 + 1 = 3$$

$$3 \times 1 = 3$$

$$3 + 2 = 5$$

$$5 \times 2 = 10$$

$$10 + 3 = 13$$

$$\mathbf{13 \times 3 = 39}$$

$$39 + 4 = 43$$

$$43 \times 4 = 172$$

$$172 + 5 = 177$$

Therefore, the missing term is 39.

5. (b) Given series; 2, 3, 8,.....,3968

Here, the pattern followed is;

$$2^2 - 1 = 3$$

$$3^2 - 1 = 8$$

$$\mathbf{8^2 - 1 = 63}$$

$$63^2 - 1 = 3968$$

Therefore, 63 is the required number.

6. (c) Given series; 1, 3, 4, 8, 15, 27, ?

Here, the pattern follow is;

Adding the three consecutive numbers to get the next number i.e.,

$$1 + 3 + 4 = 8$$

$$3 + 4 + 8 = 15$$

$$8 + 15 + 27 = 50$$

Therefore, the next term of series is 50.

7. (b) Given series; 1, 5, 14, 30, 55, 91, ?

Here, the pattern is

$$1 + 2^2 = 5$$

$$5 + 3^2 = 14$$

$$14 + 4^2 = 30$$

$$30 + 5^2 = 55$$

$$55 + 6^2 = 91$$

$$91 + 7^2 = 140$$

Therefore, the next term is 140.

8. (b) Given series: 51, 52, 60, 87, 151,.....,492

Here, the pattern is:

$$51 + 1^3 = 52$$

$$52 + 2^3 = 60$$

$$60 + 3^3 = 87$$

$$87 + 4^3 = 151$$

$$151 + 5^3 = 276$$

$$276 + 6^3 = 492$$

Therefore, the missing value is 276.

9. (b) Given, *AZ, GT, MN,....., YB, EV*

We have,

1	2	3	4	5	6	7	8	9	10	11	12	13
A	B	C	D	E	F	G	H	I	J	K	L	M
26	25	24	23	22	21	20	19	18	17	16	15	14
14	15	16	17	18	19	20	21	22	23	24	25	26
N	O	P	Q	R	S	T	U	V	W	X	Y	Z
13	12	11	10	9	8	7	6	5	4	3	2	1

$$A + 6 = G, G + 6 = M$$

$$\text{Thus, } M + 6 = S$$

$$\text{Also, } Z - 6 = T, T - 6 = N$$

$$\text{Therefore, } N - 6 = H$$

Hence, the missing term is *SH*.

10. (c) Given, *P 3 C; R 5 F; T 8 I; V 12 L; _____?*

A	B	C	D	E	F	G	H	I	J
1	2	3	4	5	6	7	8	9	10

K	L	M	N	O	P	Q	R	S	T
11	12	13	14	15	16	17	18	19	20

U	V	W	X	Y	Z
21	22	23	24	25	26

Using the positional value of each letter as mentioned above, we get

P	+ 2 = R	+ 2 = T	+ 2 = V	+ 2 = X
3	+ 2 = 5	+ 3 = 8	+ 4 = 12	+ 5 = 17
C	+ 3 = F	+ 3 = I	+ 3 = L	+ 3 = O

Therefore, the missing term is *X17O*.

Hence the correct option is (c).

11. (c) Given series: *A, CD, GHI, ?, UVWXY*

Here,

First term: *A*

$$\text{then, } A + 2 = C$$

Second term: *CD*

$$\text{then, } D + 3 = G$$

Third term: *GHI*

$$\text{then, } I + 4 = M$$

Therefore, the missing term is *MNOP*.

12. (c) Given series; *FMAMJJASON*

Here, *F* = February, *M* = March, *A* = April, *M* = May, *J* = June, *J* = July, *A* = August, *S* = September, *O* = October, *N* = November.

Therefore, *D* = December, *J* = January, *F* = February

Hence, the required term is *DJF*.

13. (a) Given; 'CLOCK' is coded as '75276' and 'EARTH' is coded as '83491'

Therefore, 'COAT' is coded as

$$C \rightarrow 7$$

$$O \rightarrow 2$$

$$A \rightarrow 3$$

$$T \rightarrow 9$$

Hence, the required code for 'COAT' is '7239'.

14. (d) Given; TAP is coded as SZO i.e.,

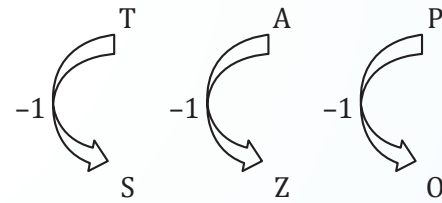

Similarly, FRIEND will be coded as EQHDMC.

Hence, the correct option is (d).

15. (a) Given; STATEMENT is coded as TNEMETATS i.e.,

On reversing the letters of word 'STATEMENT' we get 'TNEMETATS'.

Similarly, on reversing the letter of the code 'POLITICAL' we get 'LACITILOP'.

16. (b) Given; INACTIVE is written as VITCANIE

Here, all the letters of the word except last letter is reversed

i.e., the letters of 'INACTIV' is reversed

Similarly, on reversing the letter of word 'COMPUTER' except the last letter, we get ETUPMOCR.

17. (b) Given; SIKKIM written as THLJLL

$$S + 1 = T$$

$$I - 1 = H$$

$$K + 1 = L$$

$$K - 1 = J$$

$$7 + 1 = J$$

$$M - 1 = L$$

Therefore, TRAINING will be coded as

$$T + 1 = U$$

$$R - 1 = Q$$

$$A + 1 = B$$

$$I - 1 = H$$

$$N + 1 = O$$

$$I - 1 = H$$

$$N + 1 = O$$

$$G - 1 = F$$

Hence, TRAINING will be coded as UQBHOHOF.

18. (d) Given; TEACHER is written as VGCEJGT

i.e.,

$$T + 2 = V, E + 2 = G, A + 2 = C, C + 2 = E, H + 2 = J, \\ E + 2 = G, R + 2 = T$$

Similarly, CHILDREN will be written as

$$C + 2 = E, H + 2 = J, I + 2 = K, L + 2 = N, D + 2 = F, \\ R + 2 = T, E + 2 = G, N + 2 = P$$

Therefore, CHILDREN will be EJKNFTGP.

19. (d) Given; TOUR is written as 1234, CLEAR is written as 56784 and SPARE is written as 90847

Thus, the codes for the letters of TEARS is as follow:

$$T \rightarrow 1$$

$$E \rightarrow 7$$

$$A \rightarrow 8$$

$$R \rightarrow 4$$

$$S \rightarrow 9$$

Therefore, the code for TEARS is 17849.

20. (a) We have,

Word RIPPLE is coded as 613382

R	I	P	P	L	E
6	1	3	3	8	2

Word LIFE is coded as 8192

L	I	F	E
8	1	9	2

Therefore, we can directly examine the code for each letter. Thus, the word PILLER can be coded as 318826.

21. (d) Given; TEACHER is written as VGCEJGT i.e.,

$$T + 2 = V$$

$$E + 2 = G$$

$$A + 2 = C$$

$$C + 2 = E$$

$$H + 2 = J$$

$$E + 2 = G$$

$$R + 2 = T$$

Similarly, CHILDREN will be written as;

$$C + 2 = E$$

$$H + 2 = J$$

$$I + 2 = K$$

$$L + 2 = N$$

$$D + 2 = F$$

$$R + 2 = T$$

$$E + 2 = G$$

$$N + 2 = P$$

Hence, CHILDREN will be coded as EJKNFTGP.

22. (c) Given; "CHAIR" is written as "GL8MV"

i.e.,

$$C + 4 = G$$

$$H + 4 = L$$

$$4 + 4 = 8$$

$$I + 4 = M$$

$$R + 4 = V$$

Therefore, "1N5T4GR4M" is written in that code as

$$1 + 4 = 5$$

$$N + 4 = R$$

$$5 + 4 = 9$$

$$T + 4 = X$$

$$4 + 4 = 8$$

$$G + 4 = K$$

$$R + 4 = V$$

$$4 + 4 = 8$$

$$M + 4 = Q$$

Hence, "1N5T4GR4M" is written as "5R9X8KV8Q".

23. (b) Given HEALTH is coded as GSKZDG i.e.,

$$H - 1 = G$$

$$E - 1 = D$$

$$A - 1 = Z$$

$$L - 1 = K$$

$$T - 1 = S$$

$$H - 1 = G$$

Thus, on reversing the code will be GSKZDG.

Similarly, for NORTH;

$$N - 1 = M$$

$$O - 1 = N$$

$$R - 1 = Q$$

$$T - 1 = S$$

$$H - 1 = G$$

Now, on reversing we get the code as GSQNM.

Hence, the code for NORTH is GSQNM.

24. (b) Given; 'MENTION' is written as 'NFOUJPO'

$$M + 1 = N$$

$$E + 1 = F$$

$$N + 1 = O$$

$$T + 1 = U$$

$$I + 1 = J$$

$$O + 1 = P$$

$$N + 1 = O$$

Therefore, the code of 'MYSTIFY' is given by

$$M + 1 = N$$

$$Y + 1 = Z$$

$$S + 1 = T$$

$$T + 1 = U$$

$$I + 1 = J$$

$$F + 1 = G$$

$$Y + 1 = Z$$

Hence, the required code is 'NZTUJGZ'.

25. (c) Given; PEAR is coded as 7519 and TOIL is coded as 2693

$$P \rightarrow 16 \rightarrow 1 + 6 = 7$$

$$E \rightarrow 5$$

$$A \rightarrow 1$$

$$R \rightarrow 18 \rightarrow 1 + 8 = 9$$

Similarly, the coded for TOIL

$$T \rightarrow 20 \rightarrow 2 + 0 = 2$$

$$O \rightarrow 15 \rightarrow 1 + 5 = 6$$

$$I \rightarrow 9$$

$$L \rightarrow 12 \rightarrow 1 + 2 = 3$$

Therefore, the code for DOCTOR will be

$$D \rightarrow 4$$

$$O \rightarrow 15 \rightarrow 1 + 5 = 6$$

$$C \rightarrow 3$$

$$T \rightarrow 20 \rightarrow 2 + 0 = 2$$

$$O \rightarrow 15 \rightarrow 1 + 5 = 6$$

$$R \rightarrow 18 \rightarrow 1 + 8 = 9$$

Hence, the code for DOCTOR will be 463269.

26. (b) We have, 2, 8, 26, 62, 122, 212,

On analysing the pattern, we get

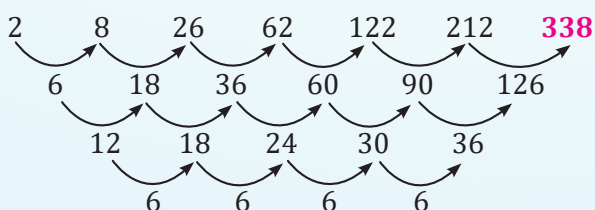

Therefore, the required number is 338.

27. (c) Given: HONEY is coded as JQPGA i.e.,

$$H + 2 = J$$

$$O + 2 = Q$$

$$N + 2 = P$$

$$E + 2 = G$$

$$Y + 2 = A$$

Now, the word for which the code is VCTIGVU can be found by subtracting 2 to each letter i.e.,

$$V - 2 = T$$

$$C - 2 = A$$

$$T - 2 = R$$

$$I - 2 = G$$

$$G - 2 = E$$

$$V - 2 = T$$

$$U - 2 = S$$

Therefore, TARGETS will be coded as VCTIGVU.

28. (a) Given; '493' means 'Friendship difficult challenge', '961' means 'Struggle difficult Exam'

Thus, the common code and number in above mentioned codes is Difficult and 9 respectively.
 \Rightarrow Difficult \rightarrow 9.

Now, '961' means 'Struggle difficult Exam' and '178' means 'Exam believable subject'

Thus, the common code and number in above mentioned codes is Exam and 1 respectively.
 \Rightarrow Exam \rightarrow 1

Thus, '178' means 'Exam believable subject'

We cannot conclude the code for believable & subject.

Hence, the code for believable can be either 7 or 8.

29. (b) Given series; 16, 25, 36, 72, 144, 196, 225

Here, the pattern followed is;

$$4^2 = 16$$

$$5^2 = 25$$

$$6^2 = 36$$

$$12^2 = 144$$

$$14^2 = 196$$

$$15^2 = 225$$

Therefore, 72 is odd one out.

30. (a) Given series; 41, 43, 47, 53, 61, 71, 83, 95

Clearly, all the numbers except 95 is prime.

Therefore, 95 is odd man out.

31. (b) Given series: 1, 5, 5, 9, 7, 11, 11, 15, 12, 17

Here, there are two alternating series such that:

$$1 + 4 = 5$$

$$5 + 2 = 7$$

$$7 + 4 = 11$$

$$11 + 2 = 13 \neq 12$$

The another series is:

$$5 + 4 = 9$$

$$9 + 2 = 11$$

$$11 + 4 = 15$$

$$15 + 2 = 17$$

Clearly, 12 is wrong term in the series.

32. (b) Given series; 7, 23, 47, 119, 171, 287

On analysing the pattern, we get

$$3^2 - 2 = 7$$

$$5^2 - 2 = 23$$

$$7^2 - 2 = 47$$

$$11^2 - 2 = 119$$

$$13^2 - 2 = 167 \neq 171$$

$$17^2 - 2 = 287$$

Therefore, 171 is odd one out.

33. (d) Given series; 190, 145, 136, 352, 460, 324, 631, 244

Here, the pattern followed is;

$$1 + 9 + 0 = 10$$

$$1 + 4 + 5 = 10$$

$$1 + 3 + 6 = 10$$

$$3 + 5 + 2 = 10$$

$$4 + 6 + 0 = 10$$

$$3 + 2 + 4 = 9 \neq 10$$

$$6 + 3 + 1 = 10$$

$$2 + 4 + 4 = 10$$

Therefore, 324 is odd one out of the series.

34. (d) Here, we have

$$\text{CEHL} \rightarrow C + 2 = E, E + 3 = H, H + 4 = L$$

$$\text{KMPT} \rightarrow K + 2 = M, M + 3 = P, P + 4 = T$$

$$\text{OQTX} \rightarrow O + 2 = Q, Q + 3 = T, T + 4 = X$$

$$\text{NPSV} \rightarrow N + 2 = P, P + 3 = S, S + 3 = V$$

Therefore, NPSV is odd one out.

35. (d) Given; BDFH, JLNP, RTVX, ZBDE Here,

$$B + 2 = D, D + 2 = F, F + 2 = H$$

$$J + 2 = L, L + 2 = N, N + 2 = P$$

$$R + 2 = T, T + 2 = V, V + 2 = X$$

$$Z + 2 = B, B + 2 = D, D + 2 = F \neq E$$

Hence, ZBDE is odd one out.



Chapter Wrap-up Test

Ready to test your knowledge?

You've got 15 questions and 20 minutes - go for it!

1. What comes next in the sequence:

7, 10, 14, 19, 25, ?

- (a) 30 (b) 32
(c) 36 (d) 42

2. What comes at last place in R, U, X, A, D?

- (a) E (b) F (c) G (d) H

3. What value should come in place of question mark (?) in the following number series?

22, 42, 64, 88, ?

- (a) 112 (b) 118
(c) 116 (d) 114

4. Find missing term of the letter series A, CD, GHI, ?, UVWXY.

- (a) LMNO (b) MNO
(c) MNOP (d) NOPQ

5. In a certain code language, '253' means 'books are old', '546' means 'man is old' and '378' means 'buy good books'. What stands for 'are' in that code?

- (a) 2 (b) 4
(c) 5 (d) 6

6. If DELHI is coded as EFMIJ then JAIPUR is coded as

- (a) JQVSBK (b) QVSKBJ
(c) BJQVSK (d) KBJQVS

7. The number that comes next in the sequence, 5.2, 4.8, 4.4, 4, is

- (a) 3.3 (b) 3.6
(c) 3.8 (d) 4.2

8. If PLAY is coded as 8123 and RHYME is coded as 49367. What will be code of MALE?

- (a) 6285 (b) 6217
(c) 6395 (d) 6198

9. Find the odd man out:

34, 105, 424, 2125, 12755

- (a) 12755 (b) 2125
(c) 424 (d) 34

10. In a certain code TEACHER is written as VGCEJGT. How is CHILDREN written in that code?

- (a) EJKNEGTP (b) EGKNFITP
(c) EJKNFGTO (d) EJKNFTGP

11. Find the odd man out from the following series: 7, 23, 47, 119, 171, 287.

- (a) 119 (b) 171
(c) 287 (d) 7

12. If Z = 52 and ACT = 48, then BAT will be equal to

- (a) 39 (b) 41
(c) 44 (d) 46

13. The missing term in the series:

ABD, DGK, HMS, MTS, ?

- (a) SBL (b) ZKV
(c) XKZ (d) ZBC

14. In the sequence, 8, 6, 9, 23, 87,, what number should come next?

- (a) 174 (b) 226
(c) 324 (d) 429

15. Find the missing terms

P 3 C; R 5 F; T 8 I; V 12 L; _____?

- (a) Y17O (b) X17M
(c) X17O (d) X16O

ANSWER KEY

1. (b) 2. (c) 3. (d) 4. (c) 5. (a) 6. (d) 7. (b) 8. (b) 9. (a) 10. (d)
11. (b) 12. (d) 13. (a) 14. (d) 15. (c)



Direction Test

Cheat Sheet by Anurag Sir

The four major directions that we commonly know are North, South, East, and West.

In addition to these cardinal directions, we have also established four more directions in between them, known as the intermediate directions. These intermediate directions are North-East, North-West, South-East, and South-West.

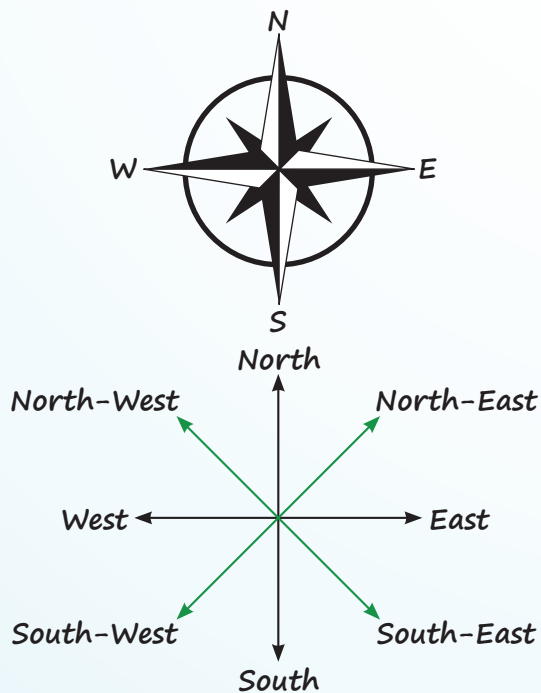

CONCEPT OF ROTATION AND DEGREE



Mean turn right



Mean turn left

Tips to Solve Direction Problems Quickly

1. Mark the Starting and Ending points clearly using distinct symbols or labels.

2. Pay close attention to left and right turns, as these change your facing direction.
3. Use a rough diagram to keep track of distances and directions.
4. Visualize or sketch turns based on the left-right movement guide above.
5. Avoid confusion by redrawing the path if needed, especially in multi-step questions.

Direction Basics

- A 90° turn from any main direction (North, South, East, West) means a shift to a perpendicular direction. Example: Facing North
→ Right turn = East, Left turn = West
- A 45° turn results in intermediate directions (Ex; North-East, South-West).

Initial Facing Direction	Left Turn →	Right Turn →
North	West	East
South	East	West
East	North	South
West	South	North

Useful Geometry: Pythagoras Theorem

To calculate the shortest distance (displacement) between two points:

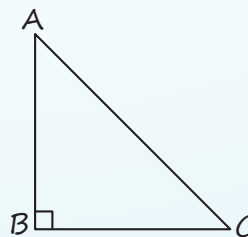

$$AC^2 = AB^2 + BC^2$$

$$\Rightarrow AC = \sqrt{AB^2 + BC^2}$$

Used when the path forms a right triangle (typically after two perpendicular movements).

QUESTIONS

- Anil started walking 5 km towards North, then he turned left and walked 3 km. Again he turned left and walked 5 km. Then the total number of km he walked is [PYQ-Jan., 2025]
(a) 8 km (b) 13 km
(c) 3 km (d) 5 km
- Raju started walking 10 km towards East from his home. He turned right and walked 5 km to the South to reach his school. In which direction is his school from his home? [PYQ-Jan., 2025]
(a) North-East (b) North-West
(c) South-East (d) South-West
- Rahim started from point X and walked straight 5 km East, then turned left and walked straight 2 km and again turned left and walked straight 7 km. In which direction is he from point X? [MTP-Jan., 2025]
(a) North-East (b) South-West
(c) South-East (d) North-West
- P, Q, R and S are playing a game of carom, P, R and S, Q are partners. S is to the right of R. If R is facing West, then Q is facing which direction? [PYQ-Dec., 2022]
(a) South (b) North
(c) East (d) West
- Laxman went 15 km to the north, then he turned west and covered 10 km. Then he turned south and covered 5 km, finally turning to east he covered 10 km. In which direction he is moving now? [PYQ-May, 2018]
(a) East (b) West
(c) North (d) South
- Manu wants to go to the market. He starts from his house towards the north and reaches a crossing after 30 m. He turns towards east, goes 10 m till the second crossing and turns again, moves towards south straight for 30 m where the marketing complex exits. In which direction is the market from his house? [PYQ-Nov., 2018]
(a) North (b) South
(c) East (d) West
- A man is facing east, then he turns left and goes 10 meters then turns right and goes 5 meters then goes 5 meters to the south and from there 5 meters to west. In which direction is he from his original place? [PYQ-May, 2018]
(a) East (b) West
(c) North (d) South
- When a person faces north and walks 25m right and she turns left and walks 20m and she again turns right and walks 25m, turns right 25m and turns right and walks 40m, in which direction is he now from his Starting point? [PYQ-June, 2019]
(a) North-West (b) North-East
(c) South-East (d) South-West
- Mr. X walks northwards. After a while, he turns to his right and a little further to his left. Finally, after walking 500 meters, he turns to his left again. In which direction is he moving now? [PYQ-Dec., 2023]
(a) North (b) South
(c) East (d) West
- A man is facing East, then he turns left and goes to 10 metres then turns right and goes 5 metres then goes 5 metres to the South and from there 5 metres to the West. In which direction is he from his original place? [PYQ-Jan., 2025]
(a) East (b) West
(c) North (d) South
- Rajni walked 20 m towards the North. Then she turned right and walks 30 m. Then she turns right and walks 35 m. Then she turns left and walks 15 m. Finally she turns left and walks 15 m. In which direction and how many meters is she from the starting position? [PYQ-May, 2025]
(a) 15 m West (b) 30 m East
(c) 30 m West (d) 45 m East
- A and B start moving towards each other from two places apart. After walking 60 m, B turns left and goes then 20 m then he turns right and goes 40 m. He then turns right again and comes back to the road on which he had started walking, if A and B walk with the same speed, what is the distance between them now? [PYQ-July, 2021]
(a) 80 m (b) 70 m
(c) 40 m (d) 60 m

13. Kamal walks 10 km North, from there he walks 6 km towards South. Then he walks 3 km towards East. How far and in which direction is he with reference to starting point? **[PYQ-May, 2025]**
- (a) 5 km North-East
(b) 5 km North-West
(c) 7 km North-East
(d) 5 km South-East
14. Shweta moved a distance of 75 m towards North She then turned to her left and walked about 25 m. turned left again and walked 80 m. Finally she turned to the right at an angle of 45. In which direction was she moving finally ? **[PYQ-Jan., 2025]**
- (a) South
(b) South-West
(c) North-East
(d) North-West
15. Deepika starts walking straight towards East. After walking 65m, she turns to the left and walks 25m straight. Again she turns to be left and walks a distance of 40m. At what distance and in which direction currently she is from the initial point? **[PYQ-June, 2023]**
- (a) 35.35 m in North-East
(b) 35.35 m in South-West
(c) 25 m in North
(d) 25 m in West
16. Mr. X walks 14 km towards north. From there he walks 8 km towards south. Then he walks 8 km towards the west. How far and in which direction is he with reference to his starting point? **[PYQ-Dec., 2023]**
- (a) 10 km, North-West
(b) 10 km, West
(c) 7 km, East
(d) 7 km, West
17. Sunitha walked 30m towards the east, took a right turn and walked 40m, then she took a left turn and walked 30m. In which direction is she now from the starting point? **[PYQ-Dec., 2023]**
- (a) North-East
(b) East
(c) South-East
(d) South
18. It is 3 o'clock on a watch, if the minute hand points towards the North-East, then the hour hand will point towards the **[PYQ-Dec., 2022]**
- (a) South
(b) South-West
(c) North-West
(d) South-East
19. One morning, after Sunrise, Vikram and Shailesh were standing in a lawn with their backs towards each other. Vikram's shadow fell exactly towards left hand side. Which direction was Shailesh facing? **[PYQ-July 2021]**
- (a) South-West
(b) West
(c) South
(d) South-East
20. A person is facing towards the North. He moves 70° clockwise direction. Again he is moving 300° clockwise direction. Now, in which direction is he presently facing? **[MTP-Jan., 2025]**
- (a) North-West (b) South-East
(c) North-East (d) South-West
21. Shrikant is facing East and turns 120° in the clockwise direction and then turns 180° in the anticlockwise direction. Which direction is Shrikant facing now? **[PYQ-June 2023]**
- (a) East (b) North-East
(c) North (d) South-West
- Read the information given below to answer the below question;**
- A, B, C, D, E, F, G, H and J are nine houses. C is 2 km East of B. A is 1 km North of B and H is 2 km South of A, G is 1 km West of H while D is 3 km East of G and F is 2 km north of G. I is situated just in the middle of B and C while E just in middle of H and D.
- [MTP-Sept., 2024]**
22. Distance between E and I is ____.
- (a) 4 km (b) 2 km
(c) 1 km (d) 3 km
23. Distance between E and G is ____.
- (a) 1 km (b) 1.5 km
(c) 2 km (d) 5 km
24. Distance between A and F is ____.
- (a) 3 km (b) 1.5 km
(c) 2 km (d) 4.5 km

ANSWER KEY

1. (b) 2. (c) 3. (d) 4. (b) 5. (a) 6. (c) 7. (c) 8. (c) 9. (d) 10. (c)
 11. (d) 12. (c) 13. (a) 14. (b) 15. (a) 16. (a) 17. (c) 18. (d) 19. (c) 20. (c)
 21. (b) 22. (c) 23. (c) 24. (c)

HINTS & SOLUTIONS

1. (b) Following the directions as given in the question, we get

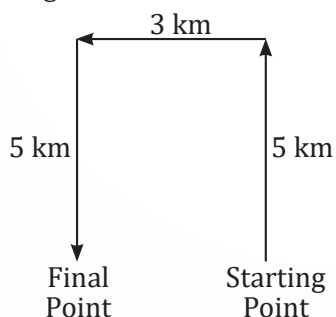

Therefore, the total distance covered = $5 + 3 + 5$
= 13 km

2. (c) Following the directions as per the question, we get

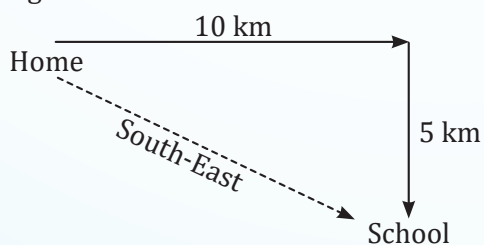

Therefore, Raju's school is at South-East direction from his home.

3. (d) Following the directions as per the question, we get

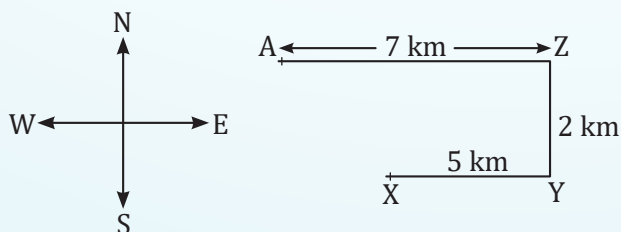

Therefore, he is moving in the North-West direction from point X.

4. (b) Given: P, Q, R and S are playing a game of carom

Since, R is facing West and P, R are partners, thus P is facing East.

Now, S is to the right of R i.e., S is facing South.

Also, S, Q are partners.

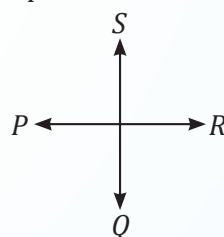

Therefore, Q will be facing North direction.

5. (a) According to the information given, the directions are:

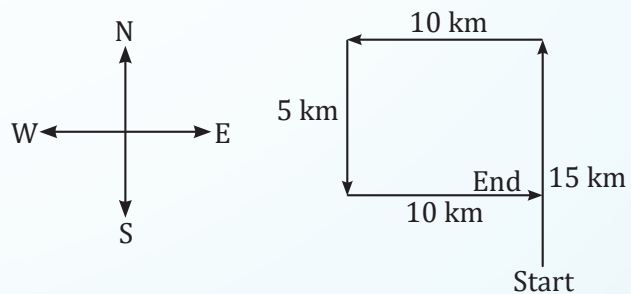

Therefore, Laxman is moving in the East direction now. Hence, the correct option is (a).

6. (c) Following the directions as per the question, we get

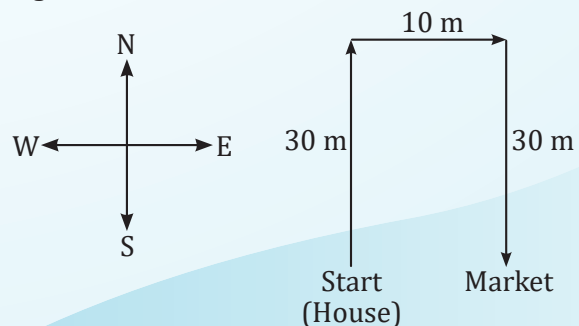

Therefore, the market is in the East direction of Manu's house. Hence, the correct option is (c).

7. (c) According to the information given, the directions are:

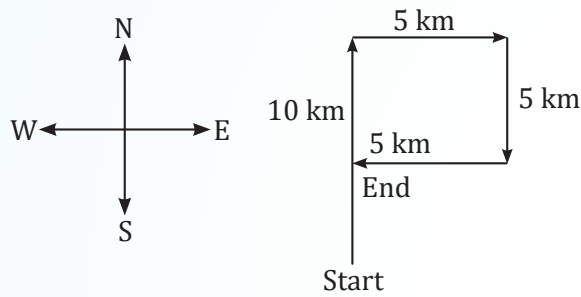

Therefore, the man is in the North direction from his original place.

Hence, the correct option is (c).

8. (c) Following the directions as per the question, we get

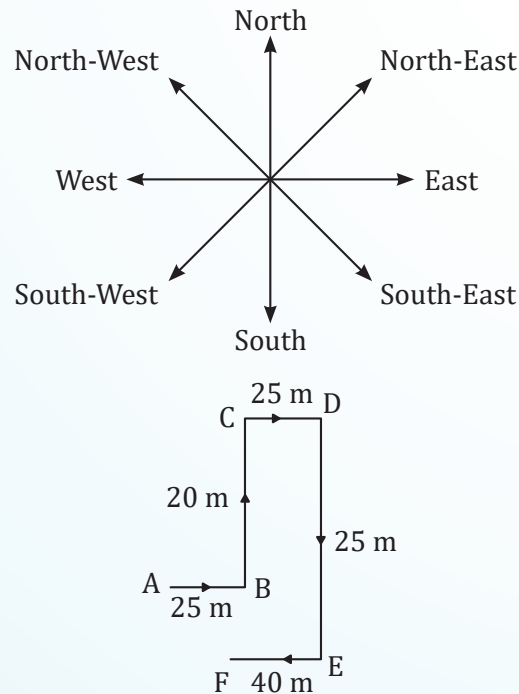

Therefore, she is in the South-East direction from her starting point.

Hence, the correct option is (c)

9. (d) Following the directions as per the given data, we get

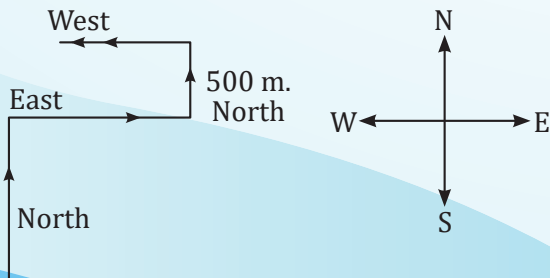

Therefore, he is moving in the West direction now.

10. (c) Given that,

A man is facing towards East and moved 10 metres in the left direction from O to A (towards North). Then, he turned 5 metres from initial A towards the right. From B , he moved 5 metres in the South (right side). In last, he turned 5 metres to the West.

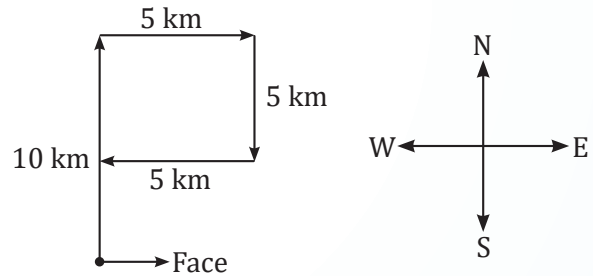

Thus, he is in the North direction from his original place.

11. (d) Following the directions as per the question, we get

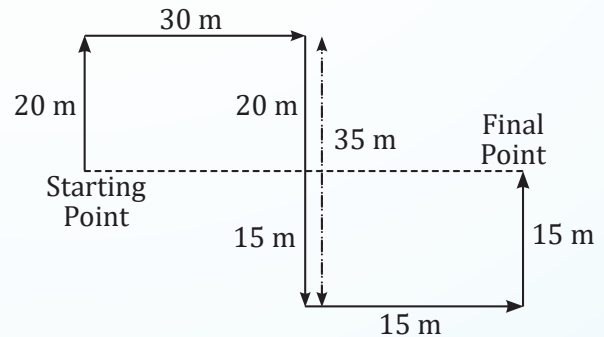

Therefore, the distance between the starting and the final point = $30 \text{ m} + 15 \text{ m} = 45 \text{ m}$ East.

12. (c) Distance traveled by A on road = $60 + 20 + 40 + 20 = 140 \text{ m}$

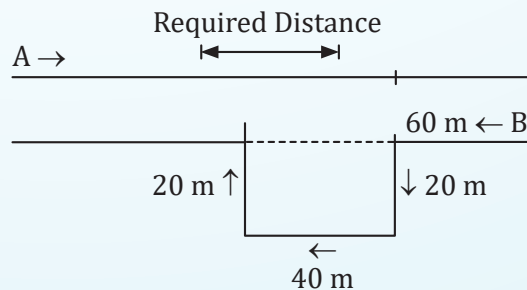

Distance traveled by B on road = $60 + 40 = 100 \text{ m}$

Required difference = $140 - 100 = 40 \text{ m}$

Hence, option (c) is correct.

13. (c) Following the directions as per the question, we get

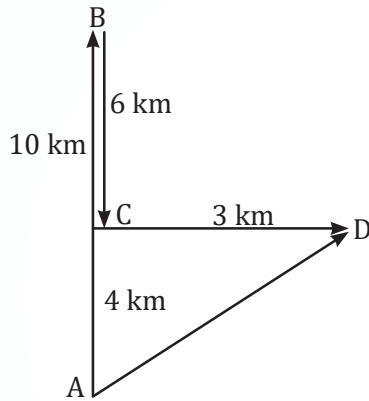

Therefore, the distance between the starting and ending point = $\sqrt{3^2 + 4^2} = \sqrt{9+16} = \sqrt{25} = 5$ km

Hence, he is 5 km North-East with reference to starting point.

14. (b) Shweta started from A, moved 75 m up to B, turned left and walked 25 m up to C.

She turned left again and moved 80 m from C to D. Turning to the right at angle 45° , she was finally moving in the direction DE i.e., North-West.

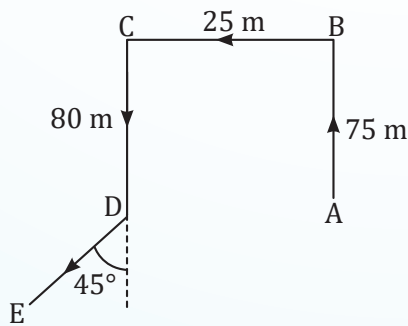

Hence, the correct option is (b).

15. (a) Let A be the initial point from where Deepika started to walk then

Following the directions as per question, we get

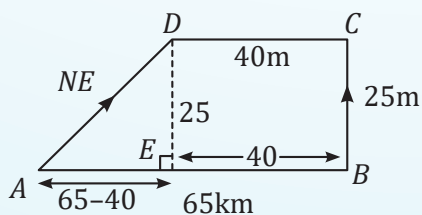

Deepika = 25 m

$AE = 65 - 40 = 25$ m

In right angle $\triangle AED$

$$\begin{aligned} AD &= \sqrt{AE^2 + DE^2} \\ &= \sqrt{25^2 + 25^2} \\ &= \sqrt{2 \times 25^2} \\ &= 25\sqrt{2} = 25 \times 1.414 = 35.35 \text{ m} \end{aligned}$$

Therefore, Deepika is at 35.35 m North-East direction from her initial point.

16. (a) Following the directions as per question, we get

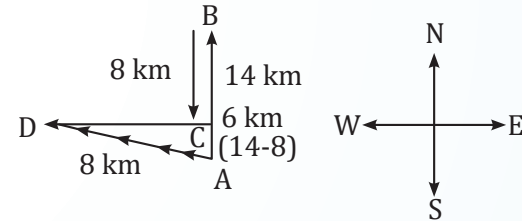

By using Pythagoras theorem

In $\triangle ACD$

$$AD = \sqrt{CD^2 + AC^2} \quad \{H^2 = P^2 + B^2\}$$

$$\begin{aligned} AD &= \sqrt{8^2 + 6^2} \\ &= \sqrt{64 + 36} = \sqrt{100} \\ &= 10 \end{aligned}$$

\therefore He is 10 km in direction of North-West.

17. (c) Let S be the starting point of Sunitha, then Following the directions as per question, we get

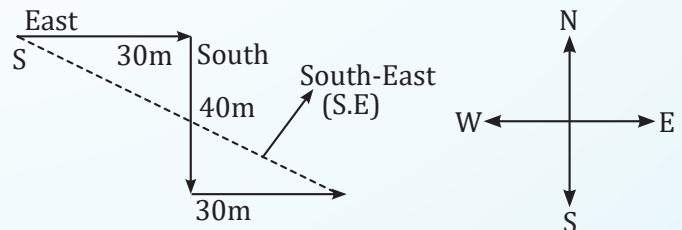

Therefore, Sunitha is at the South-West position from her starting point.

18. (d) According to question, we have

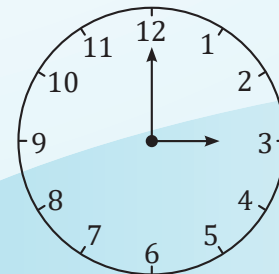

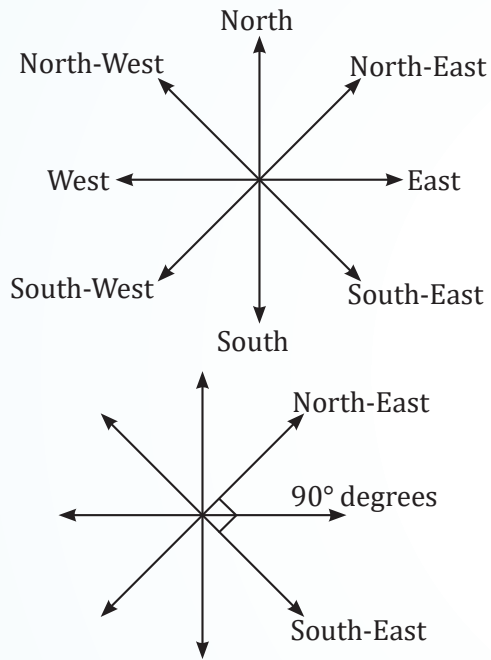

At 3 o'clock, the angle between the minute and the hour hand is 90 degrees. Now, according to the question, the minute hand points towards the North-East.

Therefore, when we move clockwise at an angle of 90 degrees, the hour hand will point towards the South-East direction.

Hence, the correct option is (d).

19. (c) We know, Sun rises in the East.

It is given that "one morning after sunrise", therefore, we will mark the Sun in the East direction in the below diagram.

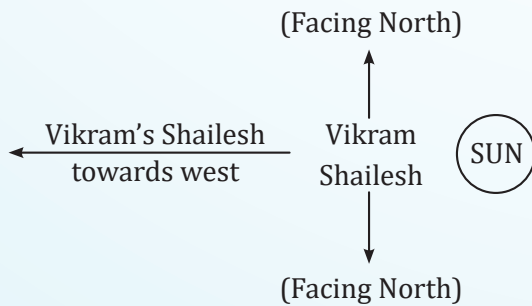

When the Sun is in the East direction, shadow of an object falls in the West.

It is given that Vikram's shadow falls towards left hand side.

This means Vikram's left hand side should be West direction.

Therefore, Shailesh is facing the South direction. Hence, the correct option is (c) i.e. South.

20. (c) Following the directions are per the question, we get

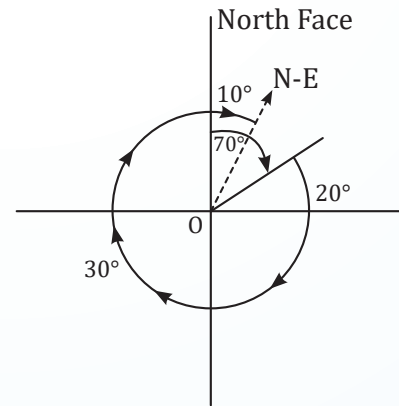
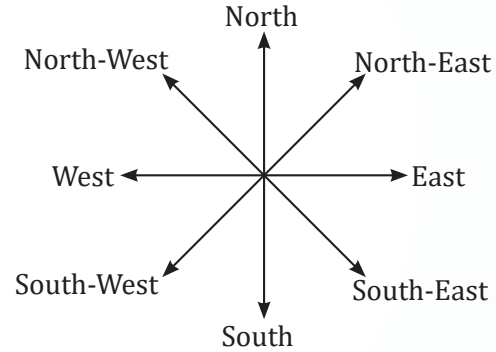

Therefore, he is presently facing the North-East direction.

21. (b) Following the directions as per question, we get

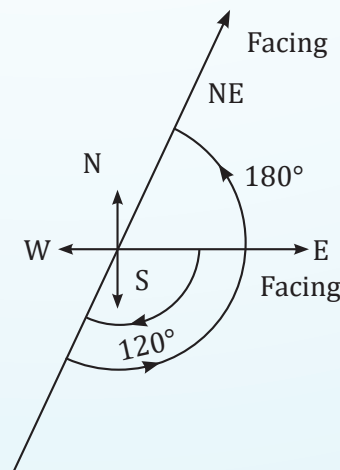

Therefore, Shrikant is facing North-East direction now.

22. (c) According to given data, we have

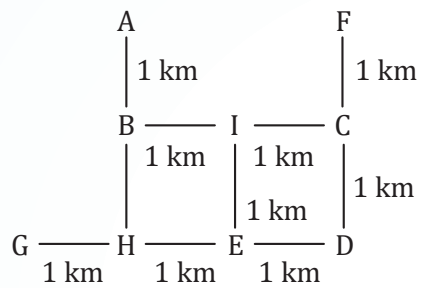

Therefore, the distance between E and I is 1 km.

23. (c) Clearly, from the above figure, we conclude that the distance between E and G is 2 km.

24. (c) Clearly, from the above figure, we conclude that the distance between A and F is 2 km.



Chapter Wrap-up Test

Ready to test your knowledge?

You've got 15 questions and 20 minutes - go for it!

1. Suresh starts from a point, walks 2 miles towards south, turns right and walks $1\frac{1}{2}$ miles, turns left and walks $\frac{1}{2}$ miles and then he turns back. What is the direction he is facing now?

(a) East (b) West
(c) South (d) North

2. Seeta starts from a point, walks 2 km towards north, turns towards her right and walks 2 km, turns right again and walks. What is the direction she is facing now?

(a) North (b) South
(c) West (d) East

3. Anil started walking 5 km towards North, then he turned left and walked 3 km. Again he turned left and walked 5 km. Then the total number of km he walked is

(a) 8 km (b) 13 km
(c) 3 km (d) 5 km

4. On walking 2 km West from her office, Sneha turned to her left and covered 4 km. From there, she turned towards East and travelled 3 km. Again she turned to West direction and walked for 1 km where she reaches to her house. In which direction her house is with respect to her office?

(a) East
(b) South
(c) North
(d) South-East

5. Sumit started from point A and walked 10 km East to point B, then turned to North and walked for 3 km to point C and then turned West and walked for 12 km to point D, then again turned South and walked for 3 km to point E. In which direction is he from his start point?

(a) East (b) North
(c) West (d) South

6. P, Q, R and S are playing a game of carom. P, R and S, Q are partners. S is to the right of R. If R is facing West, then Q is facing which direction?

(a) South (b) North
(c) East (d) West

7. Y is in the east of X which is in the north of Z. If P is in the south of Z, then in which direction of Y is P?

(a) North (b) South
(c) South-East (d) South-West

8. One day Ram left home and bi-cycled 10 km southwards, turned right and travelled 5 km and turned right and went 10 km he turned left and went 10 km. How many kilometers does he has to cycle to reach his home straight?

(a) 10 (b) 15
(c) 20 (d) 25

9. A walks 3 km northward and then he turns left and goes 2 km. He again turns left and goes 3 km. He turns right and walks straight. In which direction is he walking now?

(a) East (b) West
(c) North (d) South

10. Raju started walking 10 km towards East from his home. He turned right and walked 5 km to the South to reach his school. In which direction is his school from his home?

(a) North-East
(b) North-West
(c) South-East
(d) South-West

11. A man is facing West. He turns 45° in the clockwise direction and then another 180° in the same direction and then 270° in the anticlockwise direction. In which direction is he facing now?

(a) South - West (b) North - West
(c) West (d) South

12. Madhuri moved a distance of 75 m towards North. She then turned to her left and walked about 25 m, turned left again and walked 80 m. Finally she turned to the right at an angle of 45° . In which direction was she moving finally ?

- (a) South-East
- (b) South-West
- (c) North-West
- (d) North-East

13. A man starts from a point, walks 8 km towards North, turns right and walks 12 km, turns left and walks 7 km turns and walks 20 km towards South, turns right and walks 12 km. In which direction is he from the starting point?

- (a) North
- (b) South
- (c) West
- (d) East

14. Ankita is facing the East direction. She turns 120° in the clockwise direction and then turns 180° in the anticlockwise direction. Which direction is she facing now?

- (a) East
- (b) West
- (c) North-East
- (d) South-East

15. Read the information given below to answer the below question;

There are 9 houses A, B, C, D, E, F, G, H and I such that C is 2 km East of B. A is 1 km north of house B, G is 1 km west of house H and house H is 2 km South of house A. While house D is 3 km East of G and F is 2 km North of D. Also, house I is situated just in the middle of house B and C whereas house E is just in the middle of house H and D.

What is the distance between A and R?

- (a) 1 km
- (b) $\sqrt{2}$ km
- (c) 2 km
- (d) $\sqrt{3}$ km

ANSWER KEY

1. (d) 2. (b) 3. (b) 4. (b) 5. (c) 6. (b) 7. (d) 8. (b) 9. (b) 10. (c)
11. (a) 12. (b) 13. (b) 14. (c) 15. (b)



11

Seating Arrangements

Cheat Sheet by Anurag Sir

Process of making an arrangement of a group of people to sit according to a pre-planned manner.

Types

□ **Linear arrangement:** Here, the arrangement of the people is linear i.e. you have to arrange them in a line.

(a) **When the direction of face is not mentioned:** In this case, we take the directions our self as base and the diagram will be as follow.

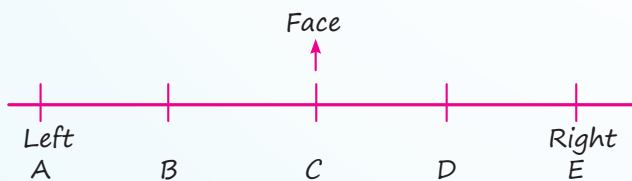

(b) **When the direction of face is towards you and the diagram will be as follow:**

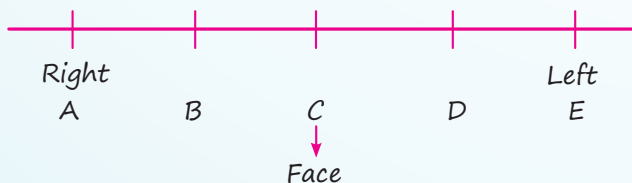

□ **Double row arrangement:** There will be two group of persons. Here, we arrange one group in one row and the other group in other row. The people in these rows normally face each other.

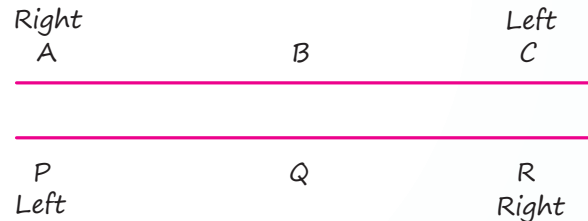

□ **Circular arrangement:** In this type of arrangement, people or objects are arranged in a circle or around a round table. The main aspects to consider are:

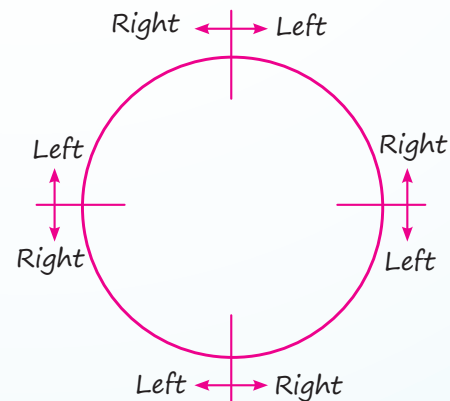

1. Moving to the left follows a clockwise direction.
 2. Moving to the right follows an anti-clockwise direction.
- ◆ The illustration represents four individuals, but the directional rules remain the same regardless of the number of people.
 - ◆ For rectangular and sequential arrangements, directions are considered similarly to those used in a two-row sequence.

QUESTIONS

Linear Arrangement

1. Five friends A, B, C, D and E are sitting in a row facing East. A is sitting between C and D. B is second to the left of C. Who is sitting at the South end? [PYQ-Jan, 2025]

(a) B (b) E
(c) C (d) D

2. P, Q, R, S and T are sitting in a line facing West. P and Q are sitting together. R is sitting at the South end and S is sitting at North end. T is the neighbour of Q and R. Who is sitting at the middle? [PYQ-Dec., 2022]

(a) P (b) Q
(c) R (d) S

3. Six persons M, N, O, P, Q and R are sitting in two rows with three persons in each row. Both the rows are in front of each other. Q is not at the end of any row. P is second to the left of R. O is the neighbour of Q and diagonally opposite to P. N is the neighbour of R. Who is in front of N? [MTP-Sep., 2024]

(a) R (b) Q
(c) P (d) M

4. A, P, R, X, S and Z are sitting in a row. S and Z are in the centre. A and P are at the ends. R is sitting to the left of A. Who is to the right of P? [MTP-Dec., 2023]

(a) A (b) X
(c) S (d) Z

5. Seven friends O, P, Q, R, S, T and U are watching movie sitting in a row. S is sitting at one extreme end. Q is sitting second to the right of S. P is sitting between O and Q. Both U and O are not sitting at extreme end. R is sitting immediate left to T. Who is sitting in the middle? [PYQ-Dec., 2023]

(a) O (b) P
(c) Q (d) U

6. Study the following information carefully and answer the questions given below.

Six friends A, B, C, D, E and F are sitting in a row facing towards North. C is sitting between A and E. D is not at the end. B is sitting at immediate right of E. F is not at the right end but D is sitting at 3rd left of E.

Which of the following is sitting to the left of D?

[PYQ-Dec., 2022]

(a) F (b) C
(c) E (d) A

7. Six friends A, B, C, D, E and F are sitting in a row facing towards North. C is sitting between A and E. D is not at the end. B is sitting at immediate right of E. F is not at the right end but D is sitting at 3rd left of E.

How many persons are there to the right of D?

[PYQ-Dec., 2022]

(a) One (b) Two
(c) Three (d) Four

Direction: Study the following information carefully and answer the questions given below.

A, B, C, D, E, F and G are sitting in a row facing North :

- (1) F is to the immediate right of E.
- (2) E is 4th to the right of G.
- (3) C is the neighbour of B and D.
- (4) Person who is third to the left of D is at one of the ends. [MTP-Sep., 2024]

8. Who are the neighbours of B?

(a) C and D (b) C and G
(c) G and F (d) C and E

9. What is the position of A ?

(a) Between E and D (b) Extreme left
(c) Centre (d) Extreme right

10. Who are the left to C?

(a) Only B (b) G, B and D
(c) G and B (d) D, G, F and A

11. Five players named as A, B, C, D and E are sitting on a bench, facing South and are waiting to be interviewed by a selector. The person C is an immediate neighbour of both A and B. The person A is the fourth person from the right end. If E is to the right of B, then where is E sitting? [PYQ-June, 2024]

(a) Fifth from the right end
(b) Fourth from the right end
(c) Fifth from the left end
(d) Fourth from the left end

12. Six friends A, B, C, D, E and F are sitting in a row facing towards North. C is sitting between A and E. D is not at the end. B is sitting at immediate right of E. F is not at the right end but D is sitting at 3rd left of E. Who is at the immediate left of C? **[PYQ-Dec, 2023]**

- (a) A
(b) E
(c) Either E or A
(d) Cannot be determined

13. Five persons are sitting on a bench to be photographed, S is to the left of N and to the right of B. M is to the right of N. R is between N and M.

Who is sitting immediate right to R.

[PYQ-Sept, 2023]

- (a) B (b) N
(c) M (d) S

14. Study the following information carefully and answer the questions given below. Six friends A, B, C, D, E and F are sitting in a row facing towards North. C is sitting between A and E. D is not at the end. B is sitting at immediate right of E. F is not at the right end but D is sitting at 3rd left of E.

How many persons are there to the right of D?

[MTP-Sept 2025]

- (a) One (b) Two
(c) Three (d) Four

15. Which of the following is sitting to the left of D?

- (a) F (b) C
(c) E (d) A

16. Who is at the immediate left of C?

- (a) A
(b) E
(c) Either E or A
(d) Cannot be determined

17. Five Friends are sitting on a bench. A is to the left of B but on the right of C, D is to the right of B but on the left of E. Who are at the extremes?

[MTP-Jan 2025]

- (a) A, B (b) A, D
(c) C, E (d) B, D

Directions to solve:

- (i) 8 persons E, F, G, H, I, J, K, and L are seated around a square table two on each side.
(ii) There are three ladies who are not seated next to each other.
(iii) J is between L and F.
(iv) G is between I and F.
(v) H, a lady member, is second to the left of J.
(vi) F, a male member, is seated opposite to E, a lady member.
(vii) There is a lady member between F and I.

[MTP-May 2025]

18. Who among following is to the immediate left of F?

- (a) G (b) I
(c) J (d) H

19. How many persons are seated between K and F?

- (a) 1 (b) 2
(c) 3 (d) 4

20. Who among the following are three lady members?

- (a) EHJ (b) EFG
(c) EHG (d) CHJ

In an exhibition, seven cars of different companies - Cadillac, Ambassador, Fiat, Maruti, Mercedes, Bedford, and Fargo are standing facing east in the following order:

1. Cadillac is next to the right of Fargo.
2. Fargo is fourth to the right of Fiat.
3. Maruti car is between Ambassador and Bedford.
4. Fiat, which is third to the left of Ambassador, is at one end.

21. Which of the cars are on both sides of the Cadillac car? **[MTP-May 2025]**

- (a) Ambassador and Maruti
(b) Maruti and Fiat
(c) Fargo and Mercedes
(d) Ambassador and Fargo

22. Which of the following statement is correct?

- (a) Maruti is next left of Ambassador.
(b) Bedford is next left of Fiat.
(c) Bedford is at one end.
(d) Fiat is next second to the right of Maruti

Read the following information carefully and then answer the questions.

Six friends A, B, C, D, E and F are sitting on a bench, facing towards North.

- I. A is sitting next to B.
- II. C is sitting left to D.
- III. D is not sitting with E.
- IV. E is on the left end of the bench.
- V. C is third position from right.
- VI. A is on the right side of B and to the right side of E.
- VII. A and C are sitting together.
- VIII. F is sitting Right of D. **[MTP-Jan 2025]**

23. At what position A is sitting?

- (a) Between B and C
- (b) Between D and C
- (c) Between E and D
- (d) Between C and E

24. What is position of B?

- (a) Second from right
- (b) Centre
- (c) Extreme left
- (d) Second from left

25. What is position of D?

- (a) Extreme from left
- (b) Extreme right
- (c) Third from left
- (d) Second from right'

Circular Arrangement

26. Five persons A, B, C, D and E are sitting in a circle facing centre. C is sitting immediate left of E. A is sitting between E and D. Who is sitting between B and A? **[PYQ-Jan., 2025]**

- (a) D
- (b) C
- (c) E
- (d) B

27. Shyam, Sathish, Aman and Pavan are playing cards. Amar is to the right of Sathish, who is to the right of Shyam. Who is to the right of Amar? **[MTP-Dec. 2023]**

- (a) Satish
- (b) Amar
- (c) Pavan
- (d) Shyam

28. P, Q, R, S, T, U, V and W are sitting round the circle and are facing the centre: P is second to the right of T who is the neighbour of R and V. S is not the neighbour of P. V is the neighbour of U. W is not between S and W. W is not between U and S.

Which one is immediate right to the V?

[MTP-May, 2025]

- (a) P
- (b) U
- (c) R
- (d) T

29. Five students are standing in a circle. Abhinav is between Alok and Ankur. Apurva is on the left of Abhishek. Alok is on the left of Apurva.

Who is sitting next to Abhinav on his right?

[MTP-Jan 2025]

- (a) Apurva
- (b) Ankur
- (c) Abhishek
- (d) Alok

ANSWER KEY

- | | | | | | | | | | |
|---------|---------|---------|---------|---------|---------|---------|---------|---------|---------|
| 1. (d) | 2. (b) | 3. (b) | 4. (b) | 5. (b) | 6. (a) | 7. (d) | 8. (d) | 9. (b) | 10. (d) |
| 11. (c) | 12. (a) | 13. (c) | 14. (d) | 15. (a) | 16. (a) | 17. (c) | 18. (c) | 19. (c) | 20. (c) |
| 21. (c) | 22. (a) | 23. (a) | 24. (d) | 25. (d) | 26. (a) | 27. (c) | 28. (d) | 29. (d) | |

HINTS & SOLUTIONS

1. (d) Given; Five friends A, B, C, D and E are sitting in a row facing East.

Also, A is sitting between C and D and B is second to the left of C, thus the final arrangement will be;

B
E
C
A
D

Therefore, D is sitting at the south end.

2. (b) Given; P, Q, R, S and T are sitting in a line facing West.

Since, P and Q are sitting together, R is sitting at the South end and S is sitting at North end & T is the neighbour of Q and R thus the arrangement will be;

S
P
Q
R
T

Therefore, Q is sitting at the middle.

3. (b) As per given information,

For row 1:

P is second to the left of R and N is the neighbour of R. As we know there are three persons in each row, so P and R will be at extreme ends.

i.e., P N R

For row 2:

O is the neighbour of Q and diagonally opposite to P. Q is not at the end of any row. So, arrangement will be:

i.e., M Q O

Thus, it is clear that Q is facing N.

4. (b) According to question, we have

A and P are at the ends & R is sitting to the left of A i.e.,

P _ _ _ R A

Now, S and Z are in the centre i.e.,

P _ S/Z Z/S R A

Thus, the final arrangement will be;

P X S/Z Z/S R A

Hence, X is sitting to the right of P.

5. (b) According to question, we have

S is sitting at one extreme end i.e.,

S _ _ _ _ _

'or' _ _ _ _ _ S

Since, Q is sitting second to the right of S thus S cannot be at extreme right i.e.,

S _ Q _ _ _ _

Now, P is sitting between O and Q i.e.,

S _ Q P O _ _

Also, Both U and O are not sitting at extreme end & R is sitting immediate left to T.

Therefore, the final arrangement is;

S U Q P O R T

Hence, P is sitting in the middle.

6. (a) According to the information,

C is sitting between A and E i.e., A C E 'or' E C A

B is sitting at immediate right of E i.e., A C E B

D is sitting at 3rd left of E i.e., D A C E B

Since, F is not at the right end and D is not at the end thus the final arrangement is:

F D A C E B

Therefore, F is sitting to the left of D.

7. (d) According to the information,

C is sitting between A and E i.e., A C E 'or' E C A

B is sitting at immediate right of E i.e., A C E B

D is sitting at 3rd left of E i.e., D A C E B

Since, F is not at the right end and D is not at the end thus the final arrangement is:

F D A C E B

Therefore, there are 4 persons to the right of D.

8. (d) According to given information,

The arrangement will be:

A F G D C B E

Therefore, C and E are the neighbours of B.

9. (b) Clearly, A is at the extreme left.

10. (d) Clearly, A, F, G and D are to the left of C.

11. (c) According to question,

Five players named as A, B, C, D and E are sitting on a bench, facing South.

Since, A is the fourth person from the right end i.e.,

Right _____ Left
 _____ A _____

Now, C is an immediate neighbour of both A and B thus

Right _____ Left
 _____ B C A _____

Also, E is to the right of B therefore the final arrangement is:

E B C A D

Hence, E is to the fifth from the left end.

12. (a) According to the information,

C is sitting between A and E i.e., A C E 'or' E C A

B is sitting at immediate right of E i.e., A C E B

D is sitting at 3rd left of E i.e., D A C E B

Since, F is not at the right end and D is not at the end thus the final arrangement is:

F D A C E B

Therefore, A is to the immediate left of C.

13. (c) According to question, the arrangement will be;

B S N R M

Therefore, M is sitting immediate right to R.

14. (d) According to given condition, the arrangement will be;

Position	1	2	3	4	5	6
Person	F	D	A	C	E	B

Therefore, A, C, E and B are right of D.

Hence, 4 persons are there to the right of D.

15. (a) Clearly, F is sitting to the left of D.

16. (a) Clearly, A is at the immediate left of C.

17. (c) According to given condition, the arrangement is;

C A B D E

Therefore, C and E are sitting at the extremes.

18. (c) From the given condition, we have

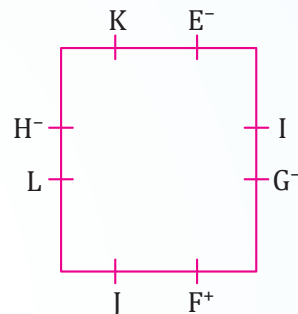

Where, negative sign represents that the person is a female and positive sign represents that the person is male.

Therefore, J is to the immediate left of F.

19. (c) Clearly, from the image, 3 persons are between K and F.

20. (c) Clearly, from the image, E, G and H are the ladies.

21. (c) The arrangement from left to right (positions 1 to 7):

- → Fiat
- → Bedford
- → Maruti
- → Ambassador
- → Forgo
- → Cadillac
- → Mercedes

Therefore, Cadillac has Fargo on the left and Mercedes on the right.

22. (a) Clearly, Maruti is next left of Ambassador.

23. (a) According to given condition, the arrangement will be;

E B A C D F

Therefore, A is sitting between B and C.

24. (d) Clearly, from the given arrangement, B is second from the left.

25. (d) Clearly, from the given arrangement, D is sitting second from the right.

26. (a) Given; Five persons A, B, C, D and E are sitting in a circle facing centre

Also, C is sitting immediate left of E and A is sitting between E and D, thus the final arrangement be;

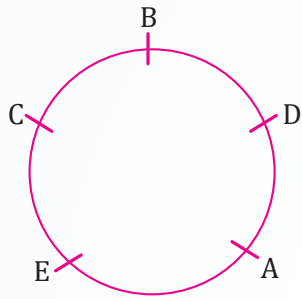

Therefore, D is sitting between B and A.

27. (c) According to question, we have Amar is to the right of Sathish, who is to the right of Shyam.

Therefore, the arrangement will be;

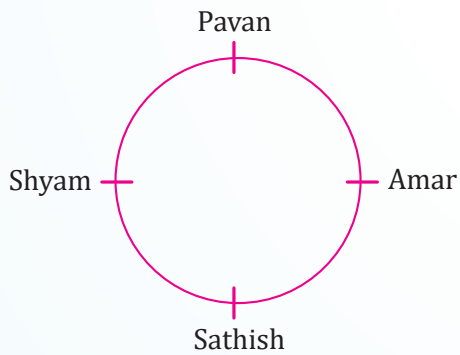

Hence, Pavan is to the right of Amar.

28. (d) According to question, we have
- P is second to the right of T

- T is the neighbor of R and V
- S is not the neighbor of P
- V is the neighbor of U
- Q is not between S and W
- W is not between U and S

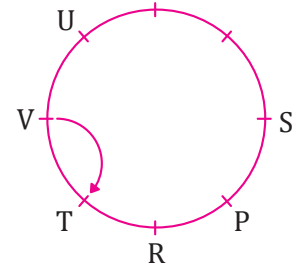

Therefore, T is to the immediate right of V.

29. (d) According to given condition, the arrangement is;

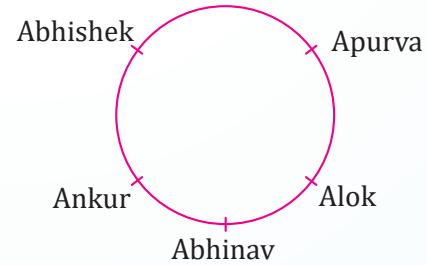

Therefore, Alok is sitting next to Abhinav on his right.



Chapter Wrap-up Test

Ready to test your knowledge?

You've got 15 questions and 20 minutes - Go for it!

1. Five distinct stations, A to E, in a row are there where A is to the north of B and E is to the south of C and north of A, B is to the north of D. Which of the stations is in the middle?

(a) D (b) B
(c) A (d) E

2. There are five different houses, A to E, in a row. A is to the right of B and E is to the left of C and right of A, B is to the right of D. Which of the houses is in the middle?

(a) A (b) B
(c) C (d) D

3. Five students A, B, C, D and E are standing in a row. D is on the right of E, B is on the immediate left of E but on the immediate right of A. D is on immediate right of C. The student in the middle is

(a) B (b) A
(c) C (d) E

4. Five boys A, B, C, D and E are sitting in a row. A is to the right of B and E is to the left of B but to the right of C. A is to the left of D. Who is second from the left end?

(a) D (b) A
(c) E (d) B

5. Five friends P, Q, R, S and T are sitting in a row facing North. Here, S is between T and Q and Q is to the immediate left of R. P is to the immediate left of T. Who is in the middle?

(a) S (b) T
(c) Q (d) R

6. Five friends P, Q, R, S, and T are sitting in a circle facing the center. T is sitting between Q and R. S is sitting to the immediate left of R. P is sitting between Q and S. Who is sitting to the immediate right of Q?

(a) S
(b) P

(c) R

(d) Cannot be determined.

7. A, P, R, X, S and Z are sitting in a row. S and Z are in the centre. A and P are at the ends. R is sitting to the left of A. Who is to the right of P?

(a) A (b) X
(c) S (d) Z

8. Five boys A, B, C, D and E are sitting in a row. A is to the right of B and E is to the left of B but to the right of C. A is to the left of D. Who is second from the left end?

(a) D (b) A
(c) E (d) B

9. Shyam, Sathish, Aman and Pavan are playing cards. Amar is to the right of Sathish, who is to the right of Shyam. Who is to the right of Amar?

(a) Satish (b) Amar
(c) Pavan (d) Shyam

10. P, Q, R, S and T are sitting in a line facing West. P and Q are sitting together. R is sitting at the South end and S is sitting at North end. T is the neighbour of Q and R. Who is sitting at the middle?

(a) P (b) Q
(c) R (d) S

11. A, B, C, D and E are sitting on a bench. A is sitting next to B, C is sitting next to D, D is not sitting with E who is on the left end of the bench. C is on the second position from the right. A is to the right of B and E. A and C are sitting together. In which position A is sitting between?

(a) C and D (b) D and E
(c) B and C (d) B and D

12. Five girls are sitting on a bench to be photographed. Seema is to the left of Rani and to the right of Bindu. Mary is to the right of Rani. Reeta is between Rani and Mary. Who is sitting immediate right to Reeta?

(a) Seema (b) Rani
(c) Bindu (d) Mary

13. Four Indian A, B, C and D and four Chinese E, F, G and H are sitting in a circle around a table facing the each other in the conference. No two Indians or Chinese are sitting side by side, C who is sitting between G and E is facing D, F is between D and A and facing G, H is to the left of B. Who is sitting left to A?

- (a) E (b) F
(c) G (d) H

14. Six girls, named P, Q, R, S, T, and V, are seated in a circle, all facing the center.

The following statements are given:

1. T is not seated between Q and S but instead, between two other individuals.
2. P is positioned immediately to the left of V.
3. R is located four seats to the right of P.

Which of the following statements is not true?

- (a) V is seated just to the right of P.
(b) T is seated just to the right of V.
(c) R is positioned second to the left of T.
(d) P is seated second to the right of R.

15. A to H are seated in a straight line facing North. C sits fourth left of G. D sits second to right of G.

Only two people sit between D and A. B and F are immediate neighbours of each other. B is not an immediate neighbour of A. H is not neighbour of D.

How many persons are seated between A and E?

- (a) One (b) Two
(c) Three (d) Four

ANSWER KEY

1. (c) 2. (a) 3. (d) 4. (c) 5. (a) 6. (b) 7. (b) 8. (c) 9. (c) 10. (b)
11. (c) 12. (d) 13. (a) 14. (c) 15. (a)



Cheat Sheet by Anurag Sir

Some Important Relations

- ❑ Children of same parent: **Siblings**
- ❑ One's husband or Wife: **Spouse**
 - ◆ Relatives on Mother's side: **Maternal**
 - ◆ Relatives on Father's side: **Paternal**
- ❑ Mother's or father's father: **Grandfather** (Maternal grandfather/Paternal grandfather)
- ❑ Mother's or father's mother: **Grandmother** (Maternal grandmother/Paternal grandmother)
- ❑ Mother's or father's brother: **Uncle**
- ❑ Mother's or father's sister: **Aunt**
- ❑ Wife's father or husband's father: **Father-in-law**
- ❑ Wife's mother or husband's mother: **Mother-in-law**
- ❑ Son's Wife: **Daughter-in-law**
- ❑ Daughter's husband: **Son-in-law**
- ❑ Husband's or Wife's brother: **Brother-in-law**
- ❑ Husband's or Wife's sister: **Sister-in-law**
- ❑ Brother's or Sister's daughter: **Niece**
- ❑ Brother's or Sister's son: **Nephew**
- ❑ Uncle's or Aunt's son or daughter: **Cousin or first cousin**
- ❑ Son or Daughter of the first cousin: **Second cousin**
- ❑ Father of grandfather or Father of grandmother: **Great grandfather**

- ❑ Mother of grandfather or Mother of grandmother: **Great grandmother**

Family Tree

A Family Tree is a diagrammatic representation of relationships among members of a family, often spanning multiple generations.

Symbols	Representation
+	Male
-	Female
↑ or ↓	One generation gap
→ or ←	Same generation
=	Husband/wife

Different generations:

Grandmother, Grandfather, Maternal grandfather, Maternal grandmother

Generation 1



Mother, Father, Uncle, Aunt, Maternal Uncle, Maternal Aunt

Generation 2



Self, Sister, Sister-in-law, Brother, Brother-in-law, Cousin

Generation 3



Son, Daughter, Nephew, Niece

Generation 4

QUESTIONS

1. Pointing to a photograph, Rajesh said, "He is Aarav and he is the son of the only daughter of the father of my brother", how is Rajesh related to the Aarav referred in the photograph?
[PYQ-May, 2025]
(a) Nephew (b) Brother
(c) Father (d) Maternal uncle
2. E is the son of A. D is the son of B. E is married to C. C is B's daughter. How is D related to E?
[MTP-Sept., 2024]
(a) Brother (b) Uncle
(c) Father-in-law (d) Brother-in-law
3. X and Y are the children of A. A is the father of X but Y is not his son. How is Y related to A?
[MTP-Dec., 2023]
(a) Son (b) Daughter
(c) Sister (d) Brother
4. C is sister of B, D is father of A. A is brother of B. D and E are married couple. How is C related to E?
[PYQ-Jan., 2025]
(a) Son (b) Daughter
(c) Mother (d) Father
5. B is daughter of A. C is brother of B. C is the only son of D. C and E are married couple. F is the only son of E. Then how is F related to A?
[PYQ-Jan., 2025]
(a) Father (b) Grandson
(c) Brother (d) Uncle
6. If X is brother of son of Y's son, then how is X related to Y?
[MTP-Dec., 2023]
(a) Brother (b) Cousin
(c) Grandson (d) Son
7. Given that X is mother of Y. Z is son of X. A is brother of B. B is daughter of Y. Who is grandmother of A?
[PYQ-Jan., 2025]
(a) Y (b) X
(c) A (d) B
8. A is the sister of B. B is the brother of C, C is the son of D. How is D related to A? [MTP-Dec., 2023]
(a) Son (b) Mother
(c) Daughter (d) Uncle
9. L is wife of N, P is son of N, K is brother of N and father of O. What is the relationship of P and O?
[PYQ-Jan., 2025]
(a) Brother (b) Uncle
(c) Cousin (d) Nephew
10. Q's mother is sister of P and daughter of M. S is daughter of P and sister of T. How is M related to T?
[MTP-Sept., 2023]
(a) Father
(b) Grandmother
(c) Grandfather or Grandmother
(d) Grandfather
11. Given that
 1. A is mother of B.
 2. C is son of A.
 3. D is brother of E.
 4. E is daughter of B.
 The grandmother of D is [MTP-Jan., 2025]
(a) A (b) B
(c) C (d) E
12. All the six members of a family namely A, B, C, D, E and F are travelling together. B is the son of C but C is not the mother of B. A and C are married couple. E is the brother of C. D is the daughter of A. F is the brother of B.
How many male members are there in the family?
[MTP-Sept., 2024]
(a) 1 (b) 2
(c) 3 (d) 4
13. A family has a man, his wife, their four sons and their wives. The family of every son also has 3 sons and one daughter. Find out the total number of male members in the whole family?
[MTP-May., 2025]
(a) 4 (b) 8
(c) 12 (d) 17
14. Ram and Mohan are brothers; Shankar is Mohan's father. Chhaya is Shankar's sister. Priya is Shankar's niece. Shubhra is Chhaya's granddaughter. Then Ram is Shubhra's
[PYQ-Nov., 2018]
(a) Brother (b) Uncle
(c) Cousin (d) Nephew

15. Pointing to the old man Kailash said "his son is my son's uncle! How is Kailash related to an old man?" [PYQ-Jun. 2019]

- (a) Brother
- (b) Either son or son in law
- (c) Father
- (d) Grand father

16. A reads a book and finds the name of the author familiar. The author 'B' is the paternal uncle of C. C is the daughter of A. How is B related to A?

[PYQ-May 2018]

- (a) Brother
- (b) Sister
- (c) Father
- (d) Uncle

17. If "A #B" means A is father of B, "A * B" means A is brother of B, "A @ B" means A is mother of B, then which of the following is correct about G @T #P? [PYQ-May, 2025]

- (a) G is mother of P
- (b) P is father of T
- (c) T is son of G
- (d) P is brother of T

18. Anita is the niece of Prateek's mother. Anita's mother is Prateek's aunt. Rohan is Anita's mother's brother. Rohan's mother is Anita's grandmother. From this information, deduce the relationship between.

Rohan's mother is _____ Anita's mother.

[PYQ-Dec. 2022]

- (a) Aunt
- (b) Mother
- (c) No relation
- (d) Sister

19. Read the following information and answer the questions given below:

Anita is the niece of Prateek's mother. Anita's mother is Prateek's aunt. Rohan is Anita's mother's brother. Rohan's mother is Anita's grandmother. From this information, deduce the relationship between.

Prateek's and Anita's mother are _____.

[PYQ-Dec. 2022]

- (a) Cousin sister
- (b) Sister-in-law
- (c) Friends
- (d) Sisters

20. Read the following information and answer the questions given below:

Anita is the niece of Prateek's mother. Anita's mother is Prateek's aunt. Rohan is Anita's mother's brother. Rohan's mother is Anita's grandmother. From this information, deduce the relationship between.

Rohan is Prateek's _____.

[PYQ-Dec. 2022]

- (a) Brother
- (b) Brother-in-law
- (c) Uncle
- (d) Cousin Brothers

21. Shobha is the niece Of Ashish. Ashish's mother is Priya. Kamla is Priya's mother. Kamla's husband is Hari. Krishna is the mother-in-law of Hari. How is Shobha related to Hari? [MTP-May, 2025]

- (a) Daughter
- (b) Great Grand daughter
- (c) Grandniece
- (d) Great Grandson's daughter

22. Pointing to a boy in a photograph, Neena said, "He is the son of my grandmother's only daughter". How is Neena related to the boy?

[MTP-May, 2025]

- (a) Mother
- (b) Aunt
- (c) Grand Mother
- (d) Sister

23. Pointing to a lady, a man said, "The son of her only brother is the brother of my wife". How is lady is related to man? [MTP-Jan., 2025]

- (a) Mother's sister
- (b) Grandmother
- (c) Sister of father-in-law
- (d) Maternal Aunt

24. A family has a man, his wife, their four sons and their wives. The family of every son also has 3 sons and one daughter. Find out the total number of male members in the whole family?

[MTP-Jan., 2025]

- (a) 4
- (b) 8
- (c) 12
- (d) 17

25. Read the following information and answer the question

'A + B' means 'A is the daughter of B'.

'A × B' means 'A is the son of B'.

'A - B' means 'A is the wife of B'.

If P × Q - S, which of the following is true?

[MTP-Jan., 2025]

- (a) S is wife of B
- (b) S is father of P
- (c) P is daughter of Q
- (d) Q is father of P

Direction (Q26-27): Read the following information.

- I. In a family six members A,B,C, D, E and F , there are two married couples.
II. D is the Grand mother of A and mother of B.
III. C is wife of B and mother of F
IV. F is grand daughter of E [MTP-Jan., 2025]
26. Who is C to A?
(a) Daughter
(b) Grandmother
(c) Mother
(d) Cannot be determined
27. How many male members are in the family ?
(a) Two
(b) Three
(c) Four
(d) Cannot be determined
28. A and B both are children of C. If C is the mother of A, A is the son of C but B is not the daughter of C, then how are A and B mutually related?
[MTP-June, 2023]
(a) A is the brother of B
(b) A is the nephew of B
(c) A is the sister of B
(d) A is the cousin of B
29. A husband and wife had five married sons and each of these had four children. How many members are there in the family?
[MTP-June, 2023]
(a) 50 (b) 40
(c) 32 (d) 36
30. Pointing to the lady in the photograph , Seema said, "Her son's father is the son-in-law of my mother." How is Seema related to the lady?
[MTP-June, 2023]
(a) Sister
(b) Mother
(c) Cousin
(d) Aunt
31. A is B's brother. C is D's father. E is B's mother. A and D are brothers. How is E related to C?
[MTP-June 2023]
(a) Sister
(b) Sister-in- law
(c) Niece
(d) Wife

32. A is B's brother, C is A's mother, D is C's father, E is B's son. How is B related to D?
[MTP-June 2023]
(a) Son (b) Granddaughter
(c) Grandfather (d) Great Grandfather
33. A is the mother of D and sister of B. B has a daughter C who is married to F. G is the husband of A. How is G related to D? [MTP-June 2023]
(a) Uncle (b) Husband
(c) Son (d) Father
34. P and Q are brothers. R and S are sister. P's son is S's brother. How is Q related to R?
[MTP-June 2023]
(a) Uncle (b) Brother
(c) Father (d) Grandfather
35. Pointing out to a photograph, a man tells his friend, "She is the daughter of the only son of my father's wife." How is the girl in the photograph related to the man?
[MTP-June 2023]
(a) Daughter (b) Mother
(c) Cousin (d) Sister
36. A party consists of grandmother, father, mother, four sons and their wives and one son and two daughters to each of the sons. How many females are there is all?
[MTP-June 2023]
(a) 14 (b) 16
(c) 18 (d) 24

Study the following information carefully

- A. A3P means A is the mother of P
B. A4P means A is the brother of P
C. A9P means A is the husband of P
D. A5P means A is the daughter of P
37. Which of the following means that K is the mother-in-law of M?
[MTP May, 2025]
(a) M9N3K4J (b) M9N5K3J
(c) K5J9M3N (d) K3J9N4M
38. In the expression $F \$ D \% K @ H * R$, how is D related to R?
(a) Father (b) Mother
(c) Sister (d) Father in law
39. In the expression $A \% B @ K * H \% P$, how is B related to P?
(a) Aunt (b) Cousin
(c) Uncle (d) Daughter

ANSWER KEY

- | | | | | | | | | | |
|---------|---------|---------|---------|---------|---------|---------|---------|---------|---------|
| 1. (d) | 2. (d) | 3. (b) | 4. (b) | 5. (b) | 6. (c) | 7. (b) | 8. (b) | 9. (c) | 10. (c) |
| 11. (a) | 12. (d) | 13. (d) | 14. (b) | 15. (b) | 16. (a) | 17. (c) | 18. (b) | 19. (d) | 20. (c) |
| 21. (b) | 22. (d) | 23. (c) | 24. (d) | 25. (b) | 26. (c) | 27. (d) | 28. (a) | 29. (c) | 30. (a) |
| 31. (d) | 32. (d) | 33. (d) | 34. (a) | 35. (a) | 36. (a) | 37. (b) | 38. (a) | 39. (a) | |

HINTS & SOLUTIONS

1. (d) According to given condition, we have

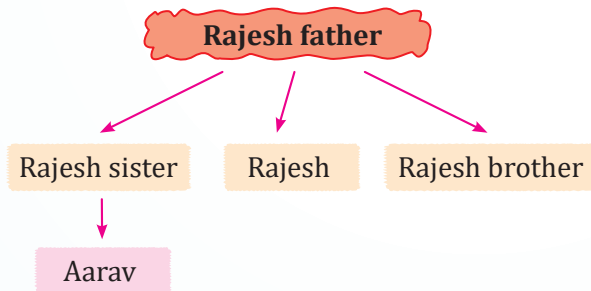

Since, Aarav is Rajesh's sister son.
Therefore, Rajesh is maternal uncle of Aarav.

2. (d) Presenting the given relations in diagram, we get

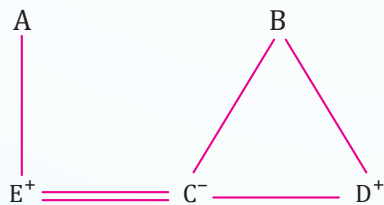

Therefore, D is brother-in-law of E.

3. (b) Presenting the given relations in diagram, we get

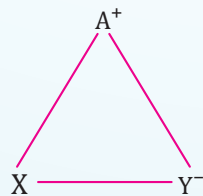

Since, Y is not A's son.
Therefore, Y is daughter of A.

4. (b) Presenting the given relations in diagram, we get

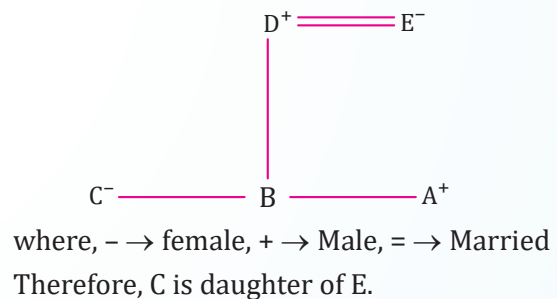

5. (b) Presenting the given relations in diagram, we get

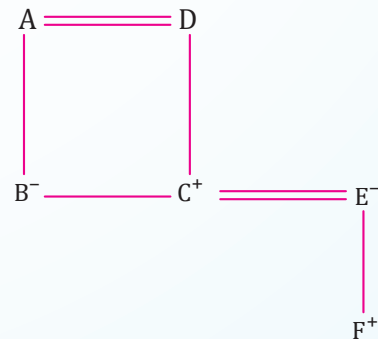

where, - → female, + → Male, = → Married
Therefore, F is grandson of A.

6. (c) Presenting the given relations in diagram, we get

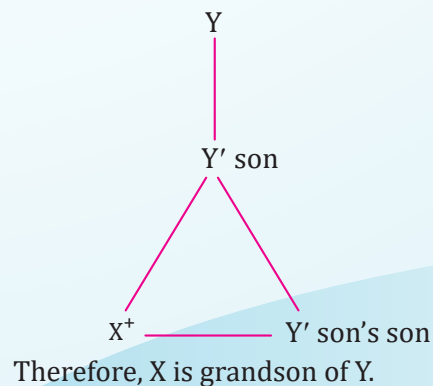

7. (b) Presenting the given relations in diagram, we get

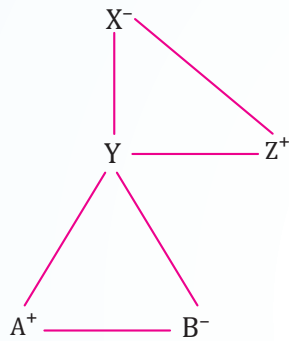

Therefore, X is grandmother of A.

8. (b) Presenting the given relations in diagram, we get

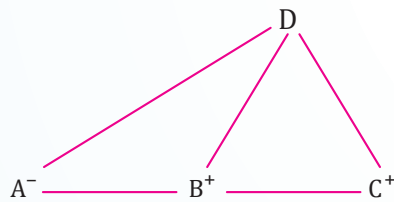

Therefore, D can be mother or father of A.

Hence, according to options, D is mother of A.

9. (c) According to given relations, we have

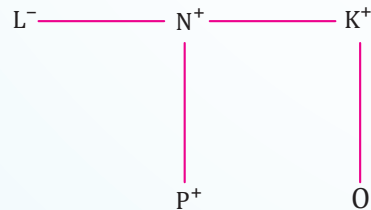

where, negative sign represent person is a female and positive sign represents person is a male.

Since, N and K are brothers and P and O are children of N and K respectively. Therefore, P and O are cousins.

10. (c) Presenting the given relations in diagram, we get

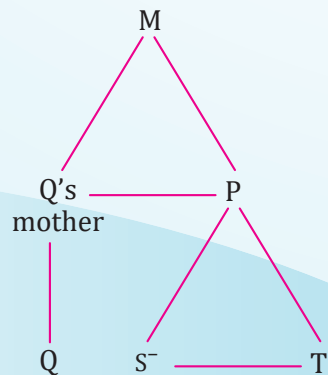

where, $- \rightarrow$ female.

Therefore, M can be Grandfather or Grandmother of T.

11. (a) According to given relation, we have

1. A is mother of B.
2. C is son of A.
3. D is brother of E.
4. E is daughter of B.

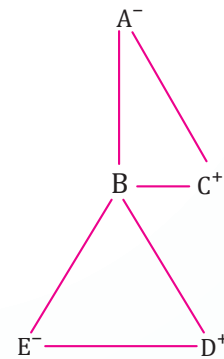

Therefore, A is grandmother of D.

12. (d) According to the given information, we have

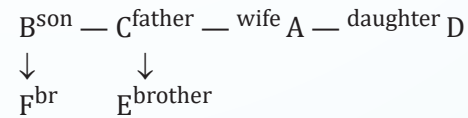

Therefore, there are 4 male members in the family.

13. (d) Given:

- A man and his wife \rightarrow 1 male
- 4 sons \rightarrow 4 males
- Each son is married \rightarrow 4 daughters-in-law (not counted here)
- Each son has 3 sons \rightarrow 4 sons \times 3 = 12 grandsons
- Each son also has 1 daughter \rightarrow not counted (since we need only males)

Now, count the male members:

1. The man \rightarrow 1
 2. His 4 sons \rightarrow 4
 3. Their sons (grandsons) \rightarrow 12
- Total male members = 1 + 4 + 12 = 17

14. (b) Make flow diagram according to the situations given,

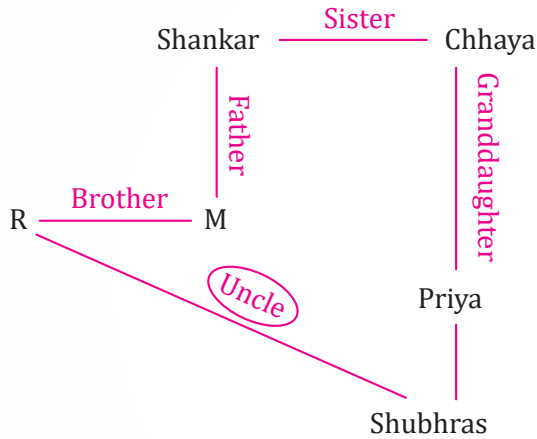

Thus, from the diagram Ram is Shubhra's Uncle.

15. (b) According to the question,

Make a flow diagram along to the scenarios,

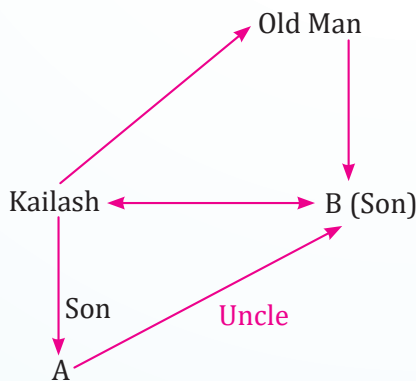

We can clearly see; Kailash is either the son or son-in-law.

16. (a) According to the question,

B is paternal uncle of C and C is daughter of A

Thus, there are two possibilities:

- (i) If A is father of C then B is brother of A.
- (ii) If A is mother of C then B is brother-in-law of A.

Out of the given options, we are given with 'brother' as a option.

The diagram according to the given scenarios,

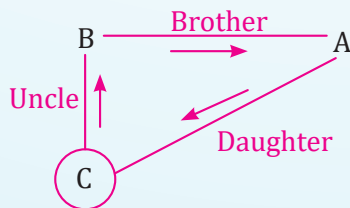

Thus, B is the brother of A.

Hence, the correct answer is option (a).

17. (c) Presenting G @ T # P in the diagram, we get

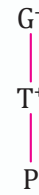

where, negative sign represent person is a female and positive sign represents person is a male.

Therefore, from above diagram, we get

T is son of G.

18. (b) According to the given information, we have

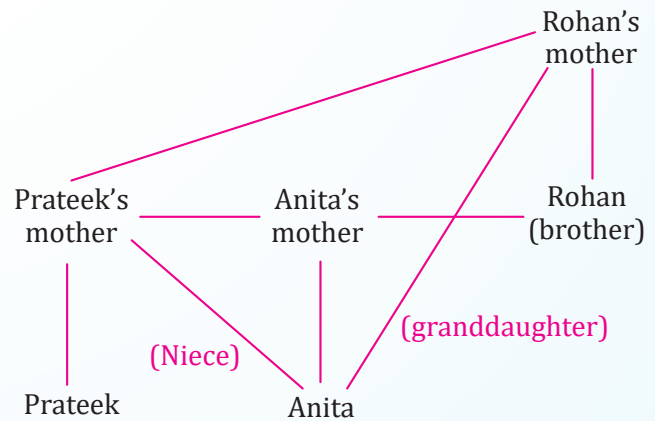

Therefore, Rohan's mother is mother Anita's mother.

19. (d) According to the given information, we get

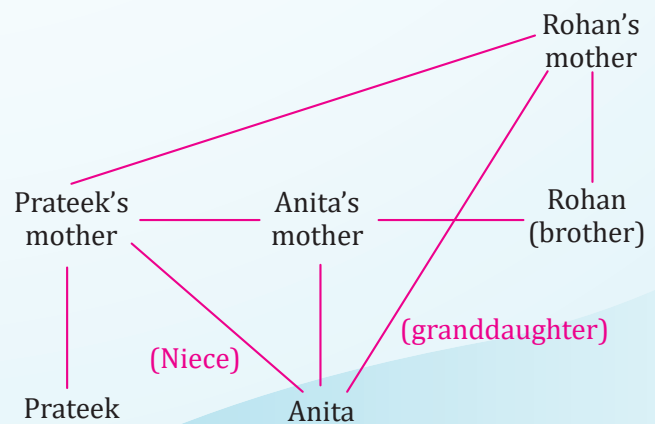

Therefore, Prateek's and Anita's mother are sisters.

20. (c) According to the given information, we have

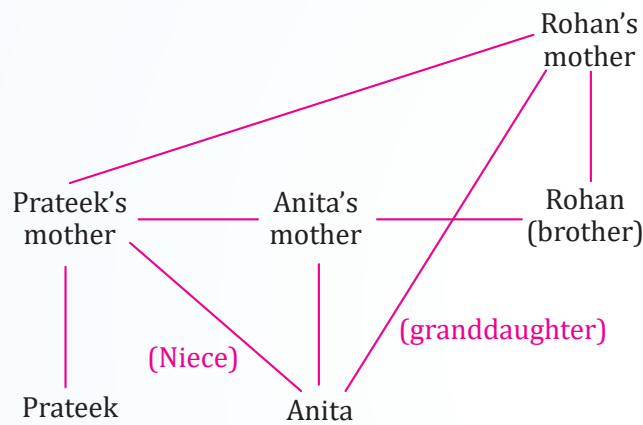

Therefore, Rohan is Prateek's Uncle.

21. (b) According to question, we have

- Ashish's mother → Priya
- Priya's mother → Kamla; Kamla's husband → Hari (so Hari is Priya's father)
- Shobha is Ashish's niece → daughter of Ashish's sibling → Priya's granddaughter

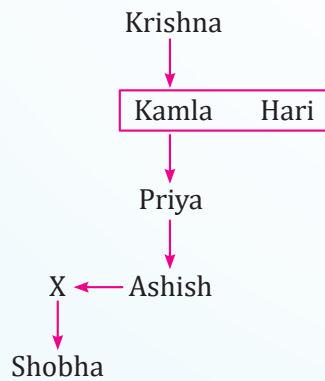

Therefore, to Priya's father (Hari), Shobha is a great-granddaughter.

22. (d) According to question, we have

"My grandmother's only daughter" = Neena's mother.

So the boy is "the son of my mother" → Neena's brother.

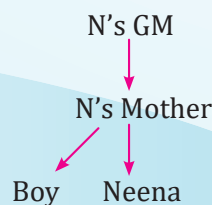

Hence Neena is his sister.

23. (c) According to question, we have

"Her only brother's son" = that brother's child.

That son is "the brother of my wife" → he's the son of my wife's father.

So "her only brother" = my wife's father (my father-in-law).

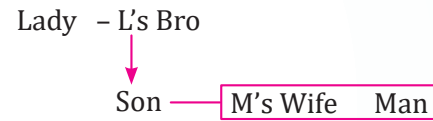

Therefore, the lady is the sister of the man's father-in-law.

24. (d) According to question, we have

- Man → 1 male
- His 4 sons → 4 males
- Each son has 3 sons → $4 \times 3 = 12$ males

Therefore, total males = $1 + 4 + 12 = 17$

25. (b) According to question, we have

- $P \times Q \Rightarrow P$ is the son of Q (so Q is P 's mother of father).
- $Q \times S \Rightarrow Q$ is the wife of S (so Q is female and S is her husband).

Therefore, Q is P 's mother, and S (her husband) is P 's father. Hence S is father of P .

26. (c) According to question, we have

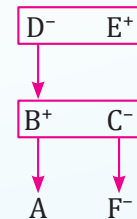

D is the grandmother of A and the mother of B → so B is a parent of A .

C is the wife of B → therefore C is the other parent of A , i.e. A 's mother.

Therefore, C is the mother of A .

27. (d) Since, A (child of B) can be either a son or a daughter — the data doesn't specify A 's gender.

Therefore the total number of males could be 2 (if A is female) or 3 (if A is male). Hence it cannot be determined from the given information.

28. (a) According to question, we have

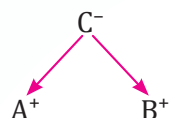

Both A and B are children of C. C is the mother, A is a son, and B is not a daughter — so B must also be a son. Two sons of the same parent are brothers.

Hence, A is B's brother.

29. (c) According to question, we have

- Couple = 2
- Five married sons = 5
- Their wives = 5
- Each son has 4 children $\rightarrow 5 \times 4 = 20$

Total = 2 (couple) + 5 + 5 + 20 = 32

30. (a) According to question, we have

“Son-in-law of my mother” means a man married to one of my mother's daughters (i.e., either Seema herself or Seema's sister). That man is also described as the father of the lady's son, so he is the lady's husband. Therefore the lady must be a daughter of Seema's mother i.e., Seema's sister.

31. (d) E is B's mother, so E is also A's mother. A and D are brothers, so D is also E's son. C is D's father, therefore C is E's husband.

Therefore, E is C's **wife**.

32. (d) C is A's mother \rightarrow C is also B's mother (since A and B are siblings).

D is C's father \rightarrow D is the grandfather of C's children (A and B).

Therefore, B (a child of C) is **D's granddaughter**.

33. (d) Since, A is D's mother and G is A's husband.

Hence, G is D's father.

34. (a) P's son is S's brother \rightarrow S is also P's child. R and S are sisters \rightarrow R is also P's child. Since Q is P's brother, thus Q is the **uncle** of R.

35. (a) According to question, we have

“My father's wife” is the man's mother. The “only son of my father's wife” is therefore the man himself (he's the only son).

Hence, the girl is the daughter of that son i.e., his **daughter**.

36. (a)

- Grandmother \rightarrow **1 female**
- Father \rightarrow male
- Mother \rightarrow **1 female**
- Four sons \rightarrow male
- Their wives \rightarrow **4 females**
- Each son as 1 son + 2 daughters $\rightarrow 4$ sons \times 2 daughters = **8 females**

Total females = 1 (grandmother) + 1 (Mother) + 4 (wives) + 8 (daughter) = 14

37. (b) According to given conditions:

For option (b): M9N5K3J

- **M9N** \rightarrow M is the husband of N \Rightarrow N is M's wife.
- **N5K** \rightarrow N is the daughter of K \Rightarrow K is a parent of N.
- **K3J** \rightarrow K is the mother of J \Rightarrow confirms K is female.

So, K is the mother of N, and N is the spouse of M \Rightarrow K is mother-in-law of M.

38. (a) According to question, we have

F \$ D \Rightarrow F is brother of D (so D is sibling of F)

D % K \Rightarrow D is father of K.

K @ H \Rightarrow H is wife of K \Rightarrow H is also D's child

H * R \Rightarrow H is wife of R \Rightarrow R is D's son-in-law

So, D is the father-in-law of R.

39. (a) According to question, we have

A % B \Rightarrow A is father of B, and B @ K \Rightarrow B is sister of K — so A is also K's father.

K * H \Rightarrow K is wife of H, and H % P \Rightarrow H is father of P.

Thus K and H are P's parents and B (K's sister) is P's aunt.



Chapter Wrap-up Test

Ready to test your knowledge?

You've got 15 questions and 20 minutes - Go for it!

- X and Y are the children of A. A is the father of X but Y is not his son. How is Y related to A?
(a) Son (b) Daughter
(c) Sister (d) Brother
- A is the sister of B. B is the brother of C, C is the son of D. How is D related to A?
(a) Son (b) Mother
(c) Daughter (d) Uncle
- E is the son of A. D is the son of B. E is married to C. C is B's daughter. How is D related to E?
(a) Brother
(b) Uncle
(c) Father-in-law
(d) Brother-in-law
- If X is brother of son of Y's son, then how is X related to Y?
(a) Brother
(b) Cousin
(c) Grandson
(d) Son
- Given that X is mother of Y. Z is son of X. A is brother of B. B is daughter of Y. Who is grandmother of A?
(a) Y (b) X
(c) A (d) B
- C is sister of B, D is father of A. A is brother of B. D and E are married couple. How is C related to E?
(a) Son (b) Daughter
(c) Mother (d) Father
- L is wife of N, P is son of N, K is brother of N and father of O. What is the relationship of P and O?
(a) Brother (b) Uncle
(c) Cousin (d) Nephew
- If "A # B" means A is father of B, "A * B" means A is brother of B, "A @ B" means A is mother of B, then which of the following is correct about G @ T # P?
(a) G is mother of P
(b) P is father of T
(c) T is son of G
(d) P is brother of T
- Pointing towards "A", "B" said, "Your mother is the younger sister of my mother". "A" is related to "B" as
(a) Uncle
(b) Cousin
(c) Nephew
(d) Father
- A and B are brother and sister respectively. C is A's father. D is C's sister and E is D's mother. How is B related to E?
(a) Grand-daughter
(b) Great grand-daughter
(c) Aunt
(d) Daughter
- Read the following information and answer the questions given below:
Anita is the niece of Prateek's mother. Anita's mother is Prateek's aunt. Rohan is Anita's mother's brother. Rohan's mother is Anita's grandmother. From this information, deduce the relationship between.
Rohan is Prateek's _____.
(a) Brother
(b) Brother-in-law
(c) Uncle
(d) Cousin Brothers
- Pointing to a lady in a photograph, Meera said, "Her father's only son's wife is my mother-in-law". How is Meera's husband related to that lady in the photo?
(a) Nephew (b) Uncle
(c) Son (d) Father

13. Suresh introduces a man as "He is the son of the woman who is the mother of the husband of my mother". How is Suresh related to the man?

- (a) Uncle (b) Son
(c) Cousin (d) Grandson

14. Rahul and Robin are brothers. Promod is Robin's father. Sheela is Pramod's sister. Prema is Promod's niece. Shubha is Sheela's grand-daughter. How is Rahul related to Shubha?

- (a) Brother (b) Cousin
(c) Uncle (d) Nephew

15. X is the husband of Y. W is the daughter of X. Z is husband of W. N is the daughter of Z. What is the relationship of N to Y?

- (a) Cousin
(b) Niece
(c) Daughter
(d) Grand-daughter

ANSWER KEY

1. (b) 2. (b) 3. (d) 4. (c) 5. (b) 6. (b) 7. (c) 8. (c) 9. (b) 10. (a)
11. (c) 12. (a) 13. (b) 14. (c) 15. (d)



Statistical Description of Data and Sampling

Cheat Sheet by Anurag Sir

UNIT-I : STATISTICAL DESCRIPTION OF DATA

Statistics

- **Statistics** is originated from
 - ◇ Latin word: Status
 - ◇ Italian word: Statista
 - ◇ German word: Statistik
 - ◇ French word: Statistique
- **Statistics in Singular Sense:** It's the statistical tool that is employed for collecting, analysing and presenting data, leading finally to drawing statistical inferences about some important characteristics.

Example: Mean, Dispersion etc.
- **Statistics in Plural Sense:** Defined as data qualitative as well as quantitative, usually collected with a view to have statistical analysis.

Example: Numerical data relating to national income, literacy etc.
- **Application of Statistics:**
 - ◇ Economics
 - ◇ Business Management
 - ◇ Commerce & Industry.
- **Limitation of Statistics:**
 - ◇ Deals in aggregates only
 - ◇ Does not deal in qualitative Data
 - ◇ Not always true
 - ◇ Expert consultation required.
- **Data:** It's the collection of quantitative information about some particular characteristics.

- **Variable:** It's a measurable quantity
 - ◇ **Discrete variable:** Variables that can only take on a finite number of values.

Example: No. of accidents etc.
 - ◇ **Continuous variable:** Variable that has an infinite number of possible values.

Example: Weight etc.
 - ◇ **Attribute:** A qualitative characteristic is Attribute.

Example: Nationality of a person etc.

Types of Data

	Primary Data	Secondary Data
Meaning	Collection of original data for the first time.	Compilation of existing data
Who collects/ compiles?	Collected by the investigator or his agents	Compiled by persons other than who collected the primary data
Cost	Relatively more costly	Relatively less costly
Use	Useful for the purpose of enquiry	Made to suit the purpose of enquiry
Personal	Possibility of personal prejudice in its collection	No possibility of personal prejudice in its compilation since such data are already collected.

Methods of Collecting Primary Data

Interview data:

1. Personal Interview
2. Indirect Interview
3. Telephonic Interview.

Investigator directly contacts the persons about whom information is to be collected.

- **Mailed Questionnaire method:** It's a form of questionnaire which is mailed to targeted individuals, which has a collection of questions on a particular topic asked to them as a part of interview which is used for conducting research on that topic. It is very low costly.

- **Observation method:** Used for research to gather data about people, objects, events etc.

- ◆ Accurate Data
- ◆ Time consuming.

- **Questionnaires filed and sent by enumerators:** It involves sending schedules through the enumerators. The enumerators contact the informants, get replies to the

questions contained in a schedule and fill them in their own handwriting in the questionnaire form. It is costly and time consuming method.

SCRUTINY

Verification

Accuracy of Data

Consistency of Data

Classification of Data

- **Chronological or Temporal:** On the basis of time.
- **Geographical or Spatial:** On the basis of Location (Place).
- **Qualitative (or Ordinal):** On the basis of characteristics or attributes like social status etc.
- **Quantitative or Cardinal:** On the basis of magnitude (a) discrete (b) continuous such as height, weight etc.

PRESENTATION OF DATA

Textual

Paragraph

Worst method

Tabular Presentation

Table

Best method
Most accurate

Diagrammatic Presentation

Line diagram

Bar diagram

Pie chart

Most attractive
(can notice hidden trend in data)

(i) **Textual method:** Method, communication researchers use to describe and interpret the characteristics of a recorded or visual message.

(ii) **Tabular method:**

1. Table Number
2. Title (which explains content of tables)
3. Headnote (Given in brackets information about the units)
4. Caption - Describes column & Subcolumns
5. Stubs-Row head
6. Body of Table - Numeric information
7. Source of Data
8. Footnote - Specific feature which is not explained

Box Head
↓
Upper part of table includes column and sub-column number

Diagrammatic Method:

- Line diagram or Histogram
- Bar diagram
- Pie diagram

Some Statistical Terms

- **Range:** Difference between the largest and smallest observations in the given data.
- **Class:** A large number of observations varying in a wide range are usually classified in several groups according to the size of their values and the groups are bounded by limits, then each group is called a class.
- **Class limit:** The smallest and largest possible values in each class of frequency distribution table.
- **Length or class interval:** Difference between the lower limit and upper limit of the class.

Methods used in Classification of Data

- **Exclusive Method:** Value of the upper limit of a class is excluded from that class interval but included in the lower limit of the next class interval.
- **Inclusive Method:** Value of the upper limit of a class is included in that very class interval.

Class Boundary

Actual class limit of a class interval.

- Lower class boundary = LCB = Lower limit class - $\frac{1}{2}D$
- Upper class boundary = UCB = Upper limit class - $\frac{1}{2}D$

Class-mark or Mid point or Mid value

Central value of the class interval.

$$\text{Mid-value or class} = \frac{\text{LCB} + \text{UCB}}{2}$$

Frequency Density

Frequency density

$$= \frac{\text{Frequency of class interval}}{\text{Length or size or width of class interval}}$$

Graphical Representation of a Frequency Curve

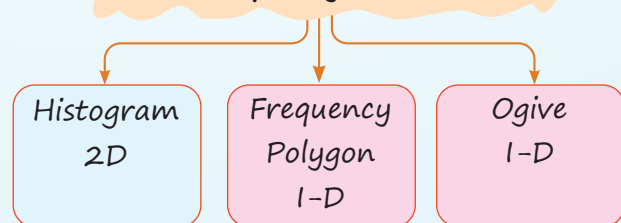

Frequency Curve

□ Bell-shaped curve:

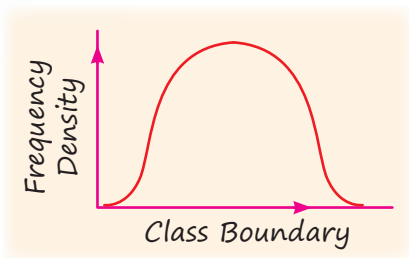

□ U-shaped curve:

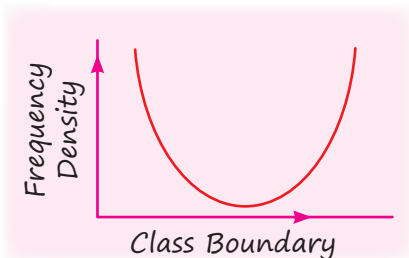

□ J-shaped curve:

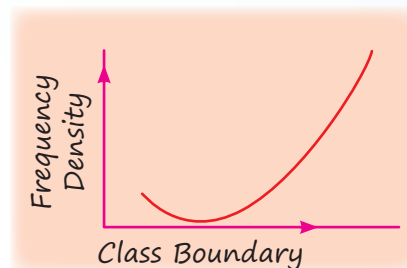

□ Mixed curve:

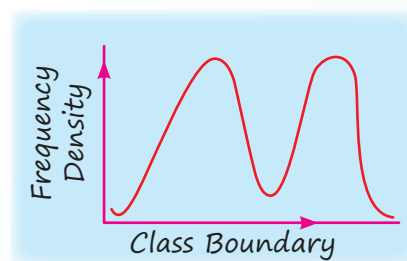

QUESTIONS

- When the data are classified in respect of successive time points, they are known as _____.
[MTP-May, 2025]
(a) Chronological data (b) Geographical data
(c) Ordinal data (d) Cordinal data
- A frequency curve which starts with a minimum frequency and then gradually reaches its maximum frequency at the other extremity is known as:
[PYQ-May, 2025]
(a) Bell-shaped curve (b) Mixed curve
(c) U-shaped curve (d) J-shaped curve
- The distribution of commuters coming to a Metro station from early morning hours to peak morning hours follows which type of frequency curve?
[PYQ-Sep. 2024]
(a) J-shaped curve (b) Bell shaped curve
(c) U-shaped curve (d) Mixed curve
- Numerical data presented in descriptive form are called:
[PYQ-Sep. 2024]
(a) Tabular presentation
(b) Classified presentation
(c) Textual presentation
(d) Graphical presentation
- What type of data is most appropriate presenting using a Pie chart?
[PYQ-Sep. 2024]
(a) Categorical data
(b) Continuous data
(c) Ordinal data
(d) Interval data
- _____ is the upper part of the table, describing the columns and sub columns. [MTP-May, 2025]
(a) Box head (b) Caption
(c) Stub (d) Body
- In tabulation, source of data, if any, is shown in the _____
[PYQ-May 2025]
(a) Footnote (b) Body
(c) Stub (d) Caption
- In tabular presentation of data, stub is _____.
[PYQ-Jan. 2025]
(a) Right part of the table providing the description of the row
(b) Left part of the table, which provide the description of rows
(c) Left part of the table providing the description of columns
(d) Right part of the table providing the description of columns

9. The column headings of a table are known as: **[MTP-Jan. 2025]**
- (a) Body (b) Stub
(c) Box-head (d) Caption
10. Ogive is used to find: **[PYQ-Jan. 2025]**
- (a) Median (b) Mean
(c) Mode (d) Range
11. The graphical representation of a cumulative frequency distribution is called **[MTP-Jan. 2025]**
- (a) Histogram (b) Ogive
(c) Both (d) None of these
12. A less than ogive **curve** is drawn by plotting **[PYQ-Jun. 2024]**
- (a) Less than Cumulative Frequencies on the vertical axis
(b) More than Cumulative Frequencies on the vertical axis
(c) Highest frequencies on vertical axis
(d) Lowest frequencies on vertical axis
13. An ogive is used to represent: **[PYQ-Jun. 2024]**
- (a) The frequency of each data point
(b) The number of data points falling below a specific value
(c) The proportion of data points falling below a specific value
(d) The relationship between two variables
14. The difference between Upper limit and lower limit of a class is called **[MTP-Jan. 2025]**
- (a) Class Interval (b) Class boundaries
(c) Mid-Value (d) Frequency
15. Series in which frequencies are continuously added corresponding to class interval in the series: **[PYQ-Sep. 2024]**
- (a) Cumulative frequency series
(b) Frequency
(c) Deviation
(d) Mid value
16. The Secondary data is collected by: **[PYQ-Sep. 2024]**
- (a) Observation method.
(b) International source like World Bank.
(c) Interview method.
(d) Mailed questionnaire method.
17. What is the range of a data set? **[PYQ-Sep. 2024]**
- (a) The difference between the mean and median of the data set
(b) The difference between the highest and lowest values in the data set
(c) The number of data points in the data set
(d) The standard deviation of the data set
18. Arrange the dimensions of Bar diagram, Cube diagram, Pie diagram in sequence **[MTP-Jan. 2025]**
- (a) 1, 2, 3 (b) 2, 1, 3
(c) 1, 3, 2 (d) 3, 2, 1
19. What does an Ogive represent? **[PYQ-Jun. 2023]**
- (a) The cumulative frequency and class boundary
(b) The frequency and class boundary
(c) The frequency and cumulative frequency
(d) The frequency and class interval
20. Frequency density corresponding to a class interval for the continuous frequency distribution, is the ratio of: **[PYQ-May, 2025]**
- (a) Class frequency to the total frequency
(b) Class frequency to the class length
(c) Class length to the class frequency
(d) Class frequency to the cumulative frequency
21. A histogram and a pie chart represent the same data on monthly expenses of a household. Which statement is most likely true? **[PYQ-Jun. 2024]**
- (a) The histogram only shows the frequency of each expense category, while the pie chart shows the proportion of each category
(b) Both histogram and pie chart show the frequency of each expense category
(c) Both histogram and pie chart show the proportion of each expense category
(d) None of these
22. The Ogive can be used for making **[PYQ-Sep. 2024]**
- (a) medium term projection
(b) short term projection
(c) long term projection
(d) group frequency distribution

23. In a cumulative frequency curve, what is represented on the y-axis? [PYQ-Dec. 2023]

- (a) Class interval
- (b) Cumulative frequency
- (c) Frequency density
- (d) Relative frequency

24. The mode of a continuous frequency distribution can be determined graphically from:

[PYQ-May, 2024]

- (a) By using Histogram
- (b) By using frequency polygon
- (c) By using ogive
- (d) By using frequency curve

25. For the non-overlapping classes 25-34, 35-44, 45-54, 55-64, the class mark of the class 35-44 is: [PYQ-Jan. 2025]

- (a) 40.5
- (b) 39.5
- (c) 35.0
- (d) 44.0

26. The curve obtained by joining the points, whose X co-ordinates are the upper limits of the class intervals and Y co-ordinates are corresponding cumulative frequencies, is called:

[PYQ-May, 2025]

- (a) Ogive
- (b) Histogram
- (c) Frequency polygon
- (d) Frequency curve

27. Bivariate Data are the data collected for

[MTP-May, 2025]

- (a) Two variables.
- (b) More than two variables.
- (c) Two variables at the same point of time
- (d) Two variables at different points of time.

28. Find the number of observations between 250 and 300 from the following data: [MTP-Jan. 2025]

Value	No. of observations
More than 200	56
More than 250	38
More than 300	15
More than 350	0

- (a) 56
- (b) 23
- (c) 15
- (d) 8

29. The following data relate to the marks of a group of students: [MTP-Jan. 2025]

Marks	No. of students
Below 10	15
Below 20	38
Below 30	65
Below 40	84
Below 50	100

How many students got marks more than 30?

- (a) 65
- (b) 50
- (c) 35
- (d) 43

30. In Pie chart, if a category represents 25% of the total data, what will be the angle of the corresponding sector? [PYQ-Jan, 2025]

- (a) 45°
- (b) 90°
- (c) 60°
- (d) 75°

31. If the range of a data is 20 and its smallest value of 5, then what is the largest value of dataset?

[PYQ-Dec. 2023]

- (a) 20
- (b) 25
- (c) 5
- (d) 30

32. The following data relate to the wages of a group of workers: [PYQ-May, 2025]

Wages (in ₹)	No. of workers
Below 100	15
Below 200	38
Below 300	65
Below 400	90

- (a) 25
- (b) 65
- (c) 90
- (d) 27

33. The following data relate to the income of 86 persons: What is the percentage of persons earning more than ₹ 1500 ? [MTP-May, 2025]

Income in ₹	No. of persons
500-999	5
1000-1499	28
1500-1999	36
2000-2499	7

- (a) 50
- (b) 45
- (c) 60
- (d) 40

34. Consider the following data where class length is given as 5. Calculate the number of class intervals; 59, 68, 78, 57, 44, 73, 40, 60, 70, 47

[PYQ-Jun. 2023]

- (a) 5 (b) 6
(c) 7 (d) 8

35. The share holding pattern of ABC Ltd. is as follows:

[PYQ-Jun. 2023]

Share holders	No. of shares in millions
Promoters	120
FII	25
MF	20
Others	20
Public	15

What is the difference between central angles of Promoters and Public in pie chart?

- (a) 216 (b) 189
(c) 180 (d) 99

36. Out of 1000 persons, 40% are female, others are male. In a marriage function, 300 persons enjoyed the song. 30% of the people who has not enjoyed the song were female. What is the number of male, who did not enjoy the song in the function?

[PYQ-Jan. 2025]

- (a) 180 (b) 120
(c) 360 (d) 490

37. Out of 1000 persons, 25 per cent were industrial workers and the rest were agricultural workers. 300 persons enjoyed world cup matches on T.V. 30 per cent of the people who had not watched world cup matches were industrial workers. What is the number of agricultural workers who had enjoyed world cup matches on TV ?

[MTP-Jan. 2025]

- (a) 230 (b) 250
(c) 240 (d) 260

ANSWER KEY

1. (a) 2. (d) 3. (a) 4. (c) 5. (c) 6. (b) 7. (a) 8. (b) 9. (d) 10. (a)
11. (b) 12. (a) 13. (b) 14. (a) 15. (a) 16. (a) 17. (a) 18. (b) 19. (a) 20. (b)
21. (a) 22. (d) 23. (b) 24. (a) 25. (b) 26. (a) 27. (c) 28. (b) 29. (c) 30. (b)
31. (b) 32. (a) 33. (a) 34. (d) 35. (b) 36. (d) 37. (d)

HINTS & SOLUTIONS

1. (a) When data are classified with respect to successive time points, such data involves time-based classification — like years, months, days, etc.

Chronological data = Data arranged according to time order.

Other options like geographical, ordinal, or cardinal refer to space/location, ranking, or quantity, not time.

2. (d) A J-shaped curve is a type of frequency curve where:

- The frequency starts low at one end,
- Then increases gradually,
- And reaches a maximum at the other extremity.

3. (a)

- The distribution of commuters starting from early morning (low frequency) and gradually increasing to peak hours (high frequency) typically resembles a J-shaped curve — starting low and rising sharply.
- A bell-shaped curve is symmetric, which doesn't fit the gradual increase scenario.
- A U-shaped curve has high frequencies at both ends and low in the middle.
- Mixed curve is a combination and doesn't specifically fit this pattern.

4. (c) When numerical data is described using words and sentences (descriptive form), it is called textual presentation.

Other options like tabular, classified, and graphical presentations involve organizing data into tables, categories, or graphs, not descriptive text.

5. (c) A Pie chart is best suited for showing parts of a whole — typically when the data is categorical, such as:

- Types of transportation (bus, train, car)
- Market share by brand
- Favorite colors, etc.

It visually displays the proportion or percentage each category contributes to the total.

6. (b) In a statistical table:

Caption is the upper part of the table, describing the columns and sub columns.

7. (a) Footnote: Located at the bottom, used for explanatory notes, including the source of data, units, or clarifications.

8. (b) The stub in a table is the leftmost column that contains the labels or descriptions of the rows.

9. (d) We know,

Caption refers to the column headings or the title.

10. (a) An ogive is a cumulative frequency graph used primarily to find the median and quartiles of a data set by plotting cumulative frequencies against class boundaries.

11. (b) An ogive is a graph that represents cumulative frequencies.

12. (a)

- A less than ogive is a graph used to represent less than cumulative frequencies.

You plot:

- Upper class boundaries on the horizontal axis (X-axis)
- Less than cumulative frequencies on the vertical axis (Y-axis)

This helps in identifying medians, quartiles, and percentiles graphically.

13. (b) An ogive is a cumulative frequency graph used to show how many data points fall below (or above) a certain value.

- A less than ogive plots cumulative frequencies that show the number of data points less than or equal to specific values.

14. (a)

- **Class Interval** = Upper limit – Lower limit
- **Class Boundaries** are the actual limits that may include decimals or adjusted values
- **Mid-Value (Class mark)** is the average of upper and lower limits
- **Frequency** is the number of observations in the class

15. (a) A cumulative frequency series is formed by continuously adding the frequencies corresponding to the class intervals.

16. (a) Secondary data refers to data that has already been collected by someone else.

Sources include published reports, databases, government records, international organisations like the World Bank.

17. (a) The difference between the highest and lowest values in the data set is the range.

18. (b)

- Bar diagram is usually 1-dimensional.
- Cube diagram is 3-dimensional.
- Pie diagram is 2-dimensional.

Therefore, the sequence (Bar, Cube, Pie) is:

1, 3, 2

19. (a) An Ogive represent the cumulative frequency and class boundary.

20. (b) We know,

Frequency density is calculated as:

$$\text{Frequency density} = \frac{\text{Class Frequency}}{\text{Class Width (or Length)}}$$

This is especially used in histograms where the class intervals (widths) are not equal. It helps in comparing how densely the data is distributed across different intervals.

21. (a) We know,

The histogram only shows the frequency of each expense category, while the pie chart shows the proportion of each category.

22. (d) An ogive is a graphical representation of the cumulative frequency distribution of data.

It helps in understanding how frequencies accumulate over classes, useful for analyzing data distributions.

23. (b) We know,

In a cumulative frequency curve, cumulative frequency is represented on the y-axis.

24. (a) The mode of a continuous frequency distribution can be graphically determined using a histogram by locating the highest rectangle (modal class) and then drawing lines from the top corners of that rectangle to the top corners of the adjacent rectangles. The point where the lines intersect the top of the modal class gives a visual estimate of the mode.

25. (b) We know,

$$\text{Class Mark} = \frac{\text{Lower Limit} + \text{Upper Limit}}{2}$$

For the class 35-44 :

$$\text{Class Mark} = \frac{35+44}{2} = \frac{79}{2} = 39.5$$

26. (a) An Ogive is a graph that represents the cumulative frequency distribution. There are two types:

Less than Ogive: Uses upper class boundaries and less-than cumulative frequencies.

More than Ogive: Uses lower class boundaries and more-than cumulative frequencies.

Here, since the X-coordinates are the upper limits and Y-values are the cumulative frequencies, this specifically describes a Less than Ogive.

27. (c) Bivariate data are data collected for:

Univariate data: One variable (e.g., heights of students)

Bivariate data: Two variables (e.g., height and weight)

It studies the relationship between two variables at the same point of time.

28. (b) Given:

Value	No. of observations
More than 200	56
More than 250	38
More than 300	15
More than 350	0

Number of observations between 250 and 300 is:
 $= (\text{More than 250}) - (\text{More than 300})$
 $= 38 - 15 = 23$

29. (c)

- Total students = 100
- Students with marks below 30 = 65
- So, students with marks more than 30
 $= 100 - 65 = 35$

30. (b) 25% of the total data is represented as follow:

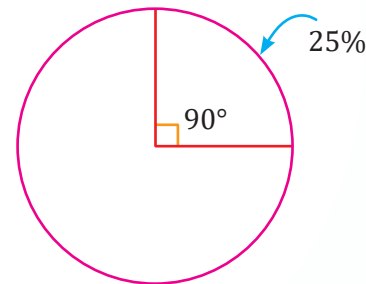

Therefore, the angle of the corresponding sector is 90° .

31. (b) Given; Range = 20 and Smallest value = 5

We know,

$$\text{Range} = \text{Largest value} - \text{Smallest value}$$

$$20 = L - 5$$

$$L = 25$$

Therefore, the largest value is 25.

32. (a) According to question, we have

$$\text{Total workers (Below 400)} = 90$$

$$\text{Workers earning below ₹300} = 65$$

$$\text{Therefore, workers earning more than ₹300} = 90 - 65 = 25$$

33. (a) Given, total pressure = 86

From the table:

- Income ₹1500-1999 → 36 persons
- Income ₹2000-2499 → 7 persons
- So, number of persons earning more than ₹1500 = $36 + 7 = 43$

$$\text{Therefore, the required percentage} = \frac{43}{86} \times 100 = 50\%$$

34. (d) Given dataset; 59, 68, 78, 57, 44, 73, 40, 60, 70, 47

We know,

$$\begin{aligned} \text{Number of classes} &= \frac{\text{Range}}{\text{Class width}} \\ &= \frac{78-40}{5} = \frac{38}{5} = 7.6 \approx 8 \end{aligned}$$

35. (b) Given;

Share holders	No. of shares in millions
Promoters	120
FII	25
MF	20
Others	20
Public	15

Therefore, the difference between Promoters and Public is given by;

$$\frac{120-15}{200} \times 360^\circ = \frac{105}{200} \times 360^\circ = 189^\circ$$

36. (d) According to the data, we have

	Enjoy song	Does not enjoy song	
Male	110	490	600
Female	190	210	400
	300	700	1000

Therefore, 490 males did not enjoy the song in the function.

37. (d) Given;

Number of people = 1000

Number of Industrial Workers = 25%

$$\frac{25}{100} \times 1000 = 250$$

Number of Agricultural Workers = (100 - 25)%
= 75%

$$= \frac{75}{100} \times 1000 = 750$$

Number of people who enjoyed World Cup = 300

Number of people who did not enjoy World Cup
= (1000 - 300) = 700

Number of people who did not watch World Cup were industrial workers

$$= \frac{30}{100} \times 700 = 210$$

Number of industrial workers who enjoyed World Cup

$$= 250 - 210 = 40$$

Number of agricultural workers who enjoyed World Cup

$$= 300 - 40 = 260$$



Chapter Wrap-up Test

Ready to test your knowledge?

You've got 15 questions and 20 minutes - Go for it!

1. The share holding pattern of ABC Ltd. is as follows:

Share holders	No. of shares in millions
Promoters	120
FII	25
MF	20
Others	20
Public	15

What is the difference between central angles of Promoters and Public in pie chart?

- (a) 216 (b) 189
(c) 180 (d) 99
2. The following table shows the distribution of the ages of a group of people:

Age (in years)	No. of people
20-30	10
30-40	20
40-50	30
50-60	25
60-70	15

How many people are aged 40 years or younger?

- (a) 10 (b) 30
(c) 50 (d) 60
3. The following data relates to the number of books sold in a bookstore:

Number of Books Sold	Number of Days
0-99	10
100-199	18
200-299	12
300-399	5

What is the percentage of days with book sales exceeding 200?

- (a) 20.55% (b) 28.75%
(c) 37.78% (d) 56.75%

4. The number of observations between 200 and 250 from the following data is:

Value	No. of observations
More than 200	56
More than 250	38
More than 300	15
More than 350	0

- (a) 56 (c) 15
(b) 23 (d) 18
5. In Pie chart, if a category represents 25% of the total data. What will be the angle of the corresponding sector?
- (a) 45° (b) 90°
(c) 60° (d) 75°
6. There are 100 students in a class out of which 60 are boys. The number of students who likes Statistics is 70 out of which 40 are boys. Find the number of the girls who do not like Statistics.
- (a) 10 (b) 20
(c) 30 (d) 40
7. For the non-overlapping classes 0-19, 20-39, 40-59, the class mark of the class 0-19 is
- (a) 0 (b) 19
(c) 9.5 (d) none
8. Relative frequency for a particular class lies between:
- (a) 0 and 1
(b) 0 and 1, both inclusive
(c) -1 and 0
(d) -1 and 1
9. Out of 1000 persons, 40% are female, others are male. In a marriage function, 300 persons enjoyed the song. 30% of the people who has not enjoyed the song were female. What is the number of male, who did not enjoy the song in the function?
- (a) 180 (b) 120
(c) 360 (d) 490

10. The following data related to the marks of group of students:

Marks	No. of Students
More than 70%	7
More than 60%	18
More than 50%	40
More than 40%	60
More than 30%	75
More than 20%	100

How many students have got marks less than 50%?

- (a) 60 (b) 82
(c) 40 (d) 53

11. A student scored 86, 79, 90, 88 and 89 in five subjects, A_1 , A_2 , A_3 , A_4 and A_5 respectively. If we need to draw a pie chart to represent these marks, then what will be the central angle for A_2 ?

- (a) 66° (b) 75°
(c) 103.2° (d) 115°

12. Out of 1000 persons, 25 percent were industrial workers and the rest were agricultural workers. 300 persons enjoyed world cup matches on T.V. 30 percent of the people who had not watched world cup matches were industrial workers. What is the number of agricultural workers who had enjoyed world cup matches on TV?

- (a) 230 (b) 250
(c) 240 (d) 260

13. A pie diagram is used to represent the following data:

Source	Revenue in Millions
Customers	120
Excise	180
Income Tax	240
Wealth Tax	180

The central angles corresponding to Income Tax and Wealth Tax are:

- (a) 90° , 120° (b) 120° , 90°
(c) 60° , 120° (d) 90° , 60°

14. The following data relate to the incomes of persons:

Income in Rs.	No. of Persons
500–999	15
1000–1499	28
1500–1999	36
2000–2499	7

What is the percentage of persons earning more than Rs. 1500?

- (a) 50% (b) 4%
(c) 40% (d) 60%

15. Cost of sugar in a month under the heads raw materials, labour, direct production and others were 12, 20, 35 and 23 units respectively. What is the difference between the central angles for the largest and smallest components of the cost of sugar?

- (a) 72° (b) 48°
(c) 56° (d) 92°

ANSWER KEY

1. (b) 2. (d) 3. (c) 4. (d) 5. (b) 6. (a) 7. (c) 8. (a) 9. (d) 10. (a)
11. (a) 12. (d) 13. (b) 14. (a) 15. (d)



UNIT-II : SAMPLING

Branches of Statistics

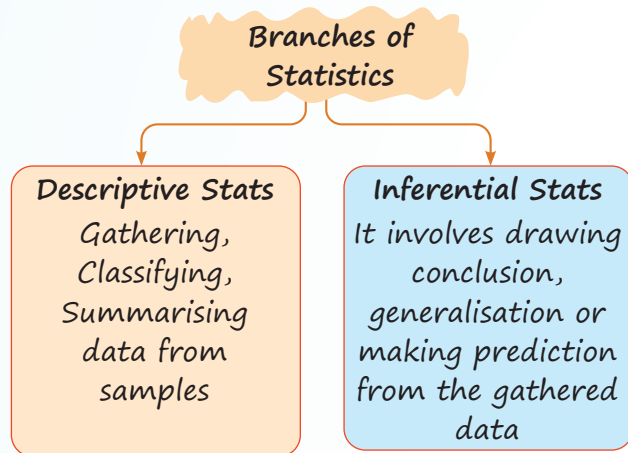

Population

- Group of People
- Group of objects
- Group of events & observations

Example: Height of male students, Blood Pressure of females between ages 40 to 60 years & Temperature in June.

Sample

Sample is a subset of Population.

“Small group of elements selected from populations.”

Number of elements in a sample is called the sample size.

Parameter

Measurable characters of populations are called Parameters.

Example: Population mean = μ
Population variance = σ^2

Principles of Sampling

Sampling is the procedure of selecting elements for a sample from population so that inferences can be drawn about population from sample.

SOME BASIC PRINCIPLES OF SAMPLING

- **Law of Statistical Regularity:** This law suggest that if a large sample is taken randomly from population, it will possess almost same characters of population.
- **Law of Inertia of large numbers:** This law is the corollary of “Law of Statistical Regularity”. This law says that “Larger the size of sample, more accurate the results are.”
- **Principle of Optimisation:** Maximum efficiency at minimum cost can be achieved only when appropriate “Sampling design” is selected.
- **Principle of Validity:** According to this law, sampling design is valid only if it is possible to obtain accurate estimates about population.

TYPES OF SAMPLING

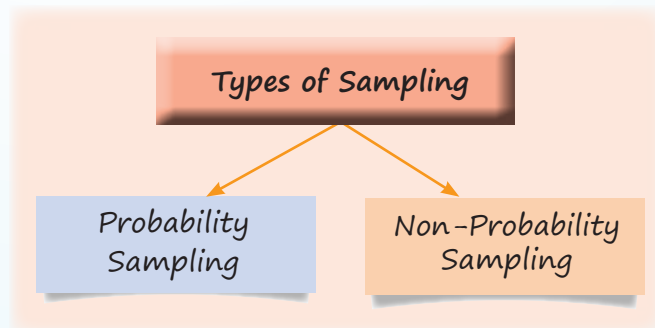

Population Sampling (Random Sampling)

When elements are randomly selected for sample.

This can be done in 4 ways:

1. **Sample Random Sampling (SRS):** In this sampling, each member of population has an equal chance of being selected in sample.

2. **Systematic Sampling (Quasi Random sampling):** In this sampling, every member of the population is assigned a number. This first member is randomly selected and then instead of choosing other randomly, we chose them in regular intervals.

3. **Stratified Sampling:** In this sampling, members are divided into subgroups called strata based on gender, Age and Income etc. After that, members are selected using Random or Systematic sampling from each subgroup.

4. **Cluster Sampling (Multi stage Sampling):** When population size is large, divide the population in subgroups (each subgroup has similar characteristic of the whole population). Then some groups are selected randomly and then members are selected from them for sample.

Non-Population Sampling (Random Sampling)

Each member is not selected randomly, so valid inferences can not be made in this type of sampling.

- ❑ **Purposive or Judgement sampling:** Based on the opinion of expert. Ex: Indian idol
- ❑ **Convenience sampling:** Those elements are selected which are easily accessible to researcher. Ex: Asking your students to complete survey regarding services provided by universities.
- ❑ **Volunteer response sampling:** People who are themselves ready to conduct the survey collect the sample data.
- ❑ **Snowball Sampling:** First select some members, then with the help of them select some more & process continues.

ERRORS IN SAMPLE SURVEY

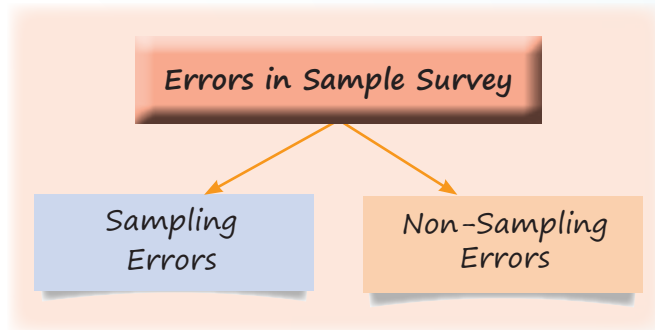

Sampling Errors

Difference between Sample statistics & population parameter because sample was not the true representative of population.

- ❑ Faulty sampling method.
- ❑ Faulty Demarcation of sampling units.
- ❑ Replacing sampling unit with unsuitable unit.
- ❑ Wrong choice of statistic.

Non-Sampling Errors

These are human errors, census & sampling both can have these errors.

- ❑ Lapse of memory
- ❑ Preference for certain digits
- ❑ Wrong measurements
- ❑ Untrained interviewer
- ❑ Biased opinion.

Population

Aggregate of all units under consideration. Population size (Denoted by 'N')

- ❑ **Finite Population:** Finite countable elements
- ❑ **Infinite Population:** Uncountable elements
 - ◆ Sample size is denoted by 'n'.
 - ◆ Detailed & complete list of all sampling units is known as Sampling frame.

- ❑ Population mean (μ) = $\frac{\sum_{i=1}^N x_i}{N}$

□ Population Porportion (P) = $\frac{X}{N}$

□ Population S.D. (σ) = $\sqrt{\frac{\sum(x_i - \mu)^2}{N}}$

Statistics

Measurable characters of sample:

$\hat{\mu}$ = Sample mean = $\bar{x} = \frac{\sum x_i}{n}$

$\hat{\sigma}$ = Sample S.D. = $\sqrt{\frac{\sum(x_i - \bar{x})^2}{n}}$

\hat{p} = Sample proportion = $p = \frac{x}{n}$

Total no. of samples with replacement = $(N)^n$

Total no. of samples without Replacement = ${}^N C_n$

Sampling Distribution

□ Standard Error of mean (\bar{x}) = $\frac{\sigma}{\sqrt{n}}$ for SRSWR

□ Standard Error of mean = $\frac{\sigma}{\sqrt{n}} \sqrt{\frac{N-n}{N-1}}$ for SRSWOR

SRSWR → Simple Random sampling with Replacement.

SRSWOR → Simple Random sampling without Replacement.

Standard Error for Proportion

□ SE(P) = $\sqrt{\frac{pq}{n}}$ for SRSWR

□ SE(P) = $\sqrt{\frac{pq}{n} \frac{N-n}{N-1}}$ for SRSWOR

$\sqrt{\frac{N-n}{N-1}}$ = Finite Population multiplier

◆ Expectation of Sampling Distribution

= $E(x) = \sum p_i x_i$

◆ Variance of Sampling Distribution

= $\sum p_i x_i^2 - (\sum p_i x_i)^2$

QUESTIONS

1. Which sampling technique is most appropriate when a person wants to ensure that subgroups are proportionally represented?

[PYQ-Jan. 2025]

- (a) Simple Random Sampling
- (b) Stratified Sampling
- (c) Multistage Sampling
- (d) Systematic Sampling.

2. Out of these, which is not a probability sampling?

[MTP-Jan. 2025]

- (a) cluster sampling
- (b) stratified sampling
- (c) quota sampling
- (d) simple random sampling.

3. Which of the following statements about simple random sampling is not true?

[PYQ-May, 2025]

(a) A Simple random sampling ensures that each unit in the population has an equal chance of being selected.

(b) In simple random sampling with replacement, each selected unit is replaced to the population before the next unit is drawn.

(c) Simple random sampling is highly effective when the population is very large and heterogeneous.

(d) In a simple random sampling without replacement, a unit is selected, it will never be selected again.

4. The law of statistical regularity says that

[PYQ-May, 2025]

(a) A Sample drawn from the population under discussion possesses the characteristics of population.

- (b) A large sample drawn at random from the population would possess the characteristics of the population.
- (c) A large sample drawn at random from the population would possess the characteristics of then population on an average.
- (d) An optimum level of efficiency can be attained at a minimum cost.
5. Which sampling is based on the discretion of the sampler? **[PYQ-Jun. 2024]**
- (a) Systematic (b) Multi-stage
(c) Stratified (d) Purposive
6. Which of the following is not a type of sampling? **[PYQ-Jun. 2024]**
- (a) Probability
(b) Non-Probability
(c) Stand-alone
(d) Mixed
7. Exit polls are an example of which method of collecting data? **[PYQ-Sep. 2024]**
- (a) Random sampling (b) Investigation
(c) Census (d) Quota Sampling
8. With the increase in sample size, the error also _____ **[MTP-Jan. 2025]**
- (a) decreases (b) increases
(c) remains same (d) all of the above
9. Standard Error (SE) and square root of sample size are: **[PYQ-Jan. 2025]**
- (a) Equal
(b) Directly proportional
(c) Inversely proportional
(d) Not equal
10. Standard Error can be described as **[MTP-Jan. 2025]**
- (a) The error committed in sampling
(b) The error committed in a sample survey
(c) The error committed in estimating parameter.
(d) Standard deviation of statistic.
11. Non-probability Sampling is also known as: **[PYQ-Jan. 2025]**
- (a) Simple Random Sampling
(b) Stratified Sampling
(c) Purposive or Judgment Sampling
(d) Cluster Sampling.
12. What is the purpose of stratified random sampling? **[PYQ-Sep. 2024]**
- (a) To ensure that every individual in the population has an equal chance of being selected.
(b) To divide the population into subgroups and then randomly sample from each subgroup.
(c) To select individuals based on the availability and convenience.
(d) To select a fixed percentage of the population without any specific criteria.
13. Standard error can be described as **[MTP-May, 2025]**
- (a) The error committed in sampling.
(b) The error committed in sample survey.
(c) The error committed in estimating a parameter.
(d) Standard deviation of a statistic.
14. Non-probability sampling is also known as **[MTP-May, 2025]**
- (a) A Stratified Sampling
(b) Simple Random Sampling
(c) Purposive or Judgement Sampling
(d) Cluster Sampling.
15. A population comprises 5 members. The number of possible samples of size $2r$ that can be drawn from it with replacement is: **[PYQ-May, 2025]**
- (a) 100 (b) 15
(c) 125 (d) 25
16. A population comprises 7 members. The number of all possible samples of size 3 that can be drawn from it with replacement is – **[PYQ-Jan. 2025]**
- (a) 343 (b) 216
(c) 21 (d) 125
17. A sample of 100 people is taken from a population of 1000. The sample mean height is 170 cm with a standard deviation of 10 cm. What is the standard error of mean? **[PYQ-Jan. 2025]**
- (a) 1.0 cm (b) 0.5 cm
(c) 1.58 cm (d) 10 cm

ANSWER KEY

1. (d) 2. (c) 3. (c) 4. (c) 5. (d) 6. (c) 7. (a) 8. (a) 9. (c) 10. (d)
11. (c) 12. (b) 13. (d) 14. (c) 15. (d) 16. (a) 17. (a)

HINTS & SOLUTIONS

1. (d) We know,

Stratified Sampling technique is most appropriate when a person wants to ensure that subgroups are proportionally represented.

2. (c) Cluster sampling, stratified sampling, and simple random sampling are probability sampling methods where every member has a known chance of selection.

Quota sampling is a non-probability sampling method based on preset quotas, not random selection.

3. (c) We know,

Simple random sampling is highly effective when the population is very large and heterogeneous is not a true statement. Hence, option (c) is correct.

4. (c) We know,

The law of statistical regularity says that a large sample drawn at random from the population would possess the characteristics of then population on an average.

5. (d) Purposive sampling is based on the discretion of the sampler.

6. (c) We know,

Probability, Non-Probability and Mixed are the types of sampling whereas Stand-alone is not a type of sampling.

7. (a) We know,

Exit polls are an example of random sampling method of collecting data.

8. (a) As sample size increases, the sampling error generally decreases because larger samples tend to better represent the population.

9. (c) The Standard Error (SE) of the mean is given by

$$SE = \frac{\sigma}{\sqrt{n}}, \quad \text{where:}$$

σ = population standard deviation (constant),
 n = sample size.

As the square root of sample size (\sqrt{n}) increases, SE decreases.

So, SE and \sqrt{n} are inversely proportional.

10. (d) The Standard Error (SE) is the standard deviation of a sampling distribution of a statistic (like the sample mean).

It measures the variability of the statistic from sample to sample.

11. (c) Non-probability sampling refers to sampling techniques where not every member of the population has a known or equal chance of being selected.

Purposive or Judgment Sampling is a type of non-probability sampling where samples are selected based on the researcher's judgment.

12. (b) The purpose of stratified random sampling is to divide the population into subgroups and then randomly sample from each subgroup.

13. (d) We know,

Standard error can be described as Standard deviation of a statistic.

14. (c) Non-probability Sampling is non-probabilistic, it is purely subjective and, as such, varies from person to person. No statistical hypothesis can be tested on the basis of a purposive sampling.

15. (d) We are given:

Population size (N) = 5

Sample size (r) = 2

When sampling with replacement, the number of possible samples of size r from a population of size N is:

$$\text{Number of samples} = N^r = 5^2 = 25.$$

16. (a) Given: Population size, $N = 7$

Sample size, $r = 3$

When sampling with replacement, the number of possible samples of size r from a population of size N is:

$$\begin{aligned} N^r &= 7^3 = 7 \times 7 \times 7 \\ &= 343 \end{aligned}$$

17. (a) Given; $n = 100$, $N = 1000$, Mean = 170 and $s = 10$

$$\text{Thus, } \frac{n}{N} = \frac{100}{1000} = 0.1$$

$$\text{Since, } \frac{n}{N} > 0.05$$

$$\text{Therefore, S.E} = \frac{\sigma}{\sqrt{n}} \sqrt{\frac{N-n}{N-1}}$$

$$\Rightarrow \text{S.E} = \frac{10}{\sqrt{100}} \sqrt{\frac{1000-100}{1000-1}}$$

$$\Rightarrow \text{S.E} = \frac{10}{10} \sqrt{\frac{990}{999}}$$

$$\Rightarrow \text{S.E} = 0.995 \approx 1.0 \text{ cm}$$



Chapter Wrap-up Test

Ready to test your knowledge?

You've got 15 questions and 20 minutes - Go for it!

1. Mr. Jerry wants to select a sample of 4 pieces of cheese out of 10 options available with replacement.

How many such samples he can choose?

- (a) 10000 (b) 210
(c) 5040 (d) 10

2. Find the population proportion of 14 laptops when total numbers of electric appliances in the showroom are 98.

- (a) 0.134 (b) 3.5
(c) 0.431 (d) 0.143

3. Which principal emphasizes on taking a large samples from population to avoid sampling errors?

- (a) Principle of Validity
(b) Law of Statistical Regularity
(c) Principle of Inertia
(d) Principle of optimization.

4. Mr. Tom wants to take a sample of 2 chairs out of 13 chairs with replacement.

How many such samples he can choose?

- (a) 26 (b) 169
(c) 78 (d) 210

5. Find the population proportion of 9 red balls when total numbers of balls are 36.

- (a) 4 (b) 0.25
(c) 0.125 (d) 2.25

6. Random sampling implies

- (a) Haphazard Sampling
(b) Probability Sampling
(c) Systematic Sampling
(d) Sampling with the same probability for each unit

7. A sample of 100 people is taken from a population of 1000. The sample mean height is 170 cm with a standard deviation

of 10 cm. What is the standard error of mean?

- (a) 1.0 cm (b) 0.5 cm
(c) 1.58 cm (d) 10 cm

8. Number of students giving the examination of Class XII [CBSE Board] is an example of

- (a) Hypothetical Population
(b) Existent Population
(c) Statistic
(d) Parameter

9. Mr. Jaggu wants to open a sweet shop near a reputed retail store in the market. He wants to purchase Raw Material like sugar besan to make the sweets. He is confused that which sampling method he should use to select the dealer who can provide him the raw materials when the quality of raw material of all the dealers is almost same. Suggest him a method of sampling.

- (a) Simple Random Sampling
(b) Systematic Sampling
(c) Judgement Sampling
(d) Stratified Sampling.

10. If from a population with 20 members, a random sample without replacement of 2 members is taken, the number of all such samples is

- (a) 300 (b) 190
(c) 50 (d) 600

11. Sampling cannot be provide significant results where _____

- (a) Population is Homogeneous
(b) Population is Heterogeneous
(c) Sample size is small
(d) Both (a) & (c)

12. If $n = 400$ and standard deviation is 8, then the value of Standard Error is

- (a) 0.4 (b) 0.8
(c) 0.2 (d) 50

13. Standard Error can be described as

- (a) The error committed in sampling
- (b) The error committed in a sample survey
- (c) The error committed in estimating parameter
- (d) Standard deviation of statistic

14. What are the possible samples if a sample is taken of 2 elements without replacement out of 3 elements namely P, Q & R?

- (a) (P,Q); (P,R); (Q,R); (P,P); (R,R); (Q,Q)
- (b) (P,Q); (P,R); (Q,R)

(c) (P,Q); (P,R); (Q,R); (P,P); (R,R); (Q,Q); (R,Q); (R,P); (Q,P)

(d) None of these

15. Mr. Mahi want to take a sample of 5 different cricket bats out of 16 options available without replacement.

How many such samples he can choose?

(a) 998

(b) 1092

(c) 2039

(d) 4368

ANSWER KEY

1. (a) 2. (d) 3. (b) 4. (b) 5. (b) 6. (d) 7. (a) 8. (b) 9. (a) 10. (b)
11. (b) 12. (a) 13. (c) 14. (b) 15. (d)



Measures of Central Tendency and Dispersion

Cheat Sheet by Anurag Sir

CENTRAL TENDENCY

- Meaning of central tendency
 - ◇ Central value of all observation.
 - ◇ Representative of entire services.
- Characters of Good Central Tendency
 - ◇ Easy to calculate → Mean and Mode
 - ◇ Easy to understand → Mean
 - ◇ Based on all observation → Mean, GM, HM
 - ◇ Rigidly defined → Mean
 - ◇ Least affected by extreme values → Median
 - ◇ Have mathematical properties → Mean, GM and HM.

👉 Note:

- AM is best central tendency.
- Median is best for open ended series.

Arithmetic Mean (\bar{X})

$$AM = \frac{\text{Sum of all observations}}{\text{Total no. of observations}}$$

Methods

Direct Method

$$\bar{X} = \frac{\sum f_i x_i}{N}$$

(where, $N = \sum F_i$)

Shortcut Method

Assume mean method

If $x_i - A = d_i$

$$\text{Then } \bar{X} = A + \frac{\sum f_i d_i}{N}$$

Step deviation method

If $\frac{x_i - A}{h} = v_i$

$$\bar{X} = A + \frac{\sum f_i v_i}{N} \times h$$

Properties

1. If all observations are same (Let K) then mean also K
Mean of 5, 5, 5, 5, 5 will be 5.
2. Sum of deviations from their arithmetic mean is always zero
i.e. $\sum (x_i - \bar{X}) = 0$
3. Sum of the squares of deviation is minimum when deviations are taken from their arithmetic mean
i.e. $\sum (x_i - k)^2$ is minimum when $k = \bar{X}$.

4. Combined mean

$$\bar{X}_{12} = \frac{N_1 \bar{X}_1 + N_2 \bar{X}_2}{N_1 + N_2}$$

5. Arithmetic mean change with change of origin and change of scale

i.e. If $y_i = ax_i + b$
Then $\bar{y} = a\bar{x} + b$

$$1 + 2 + 3 + \dots + n = \frac{n(n+1)}{2}$$

$$1^2 + 2^2 + 3^2 + \dots + n^2 = \frac{n(n+1)(2n+1)}{6}$$

$$1^3 + 2^3 + 3^3 + \dots + n^3 = \left[\frac{n(n+1)}{2} \right]^2$$

A.M. of first 'n' natural numbers = $\frac{n+1}{2}$

Median

A number which divides entire distribution in two parts is known as median. It represents half (50%) of total numbers.



- It is not based on all observations so it can be used for open ended series.

Methods

For individual and discrete series

Median

$$= \left(\frac{n+1}{2} \right)^{\text{th}} \text{ term}$$

For continuous series

- Make CF column
- Locate $\frac{N}{2}$ in CF
- Select median class
- Use formula

Median

$$= l + \left[\frac{\frac{N}{2} - CF}{F} \right] \times h$$

- Median changes with change of origin and change in scale

i.e. if $y = a + bx$

then med. of $y = a + b$ (med. of x)

- Sum of absolute deviation is minimum when deviations are taken from the median

i.e. $\sum |x_i - k|$ is minimum.

when $k = \text{median}$.

PARTITION VALUES (FRACTILES)

Quartiles (Q_1 , Q_2 and Q_3)

Divides entire series in 4 parts :

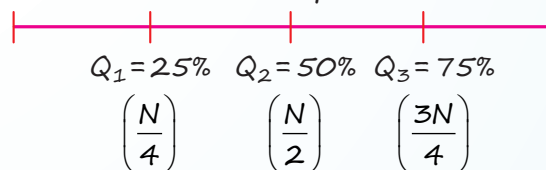

For Individuals and Discrete series :

$$Q_1 = \left(\frac{n+1}{4} \right)^{\text{th}}$$

$$Q_2 = \text{Median} = \left(\frac{n+1}{2} \right)^{\text{th}}$$

$$Q_3 = \left[3 \left(\frac{n+1}{4} \right) \right]^{\text{th}} \text{ term}$$

In continuous series:

For Q_1	For Q_3
• Locate $\frac{N}{4}$ in CF	• Locate $\frac{3N}{4}$ in CF
• Select ' Q_1 ' class	• Select Q_3 class
• $Q_1 = l + \left[\frac{\frac{N}{4} - CF}{F} \right] \times h$	• $Q_3 = l + \left[\frac{\frac{3N}{4} - CF}{F} \right] \times h$

Deciles ($D_1, D_2 \dots D_9$)

Divides entire series in 10 parts:

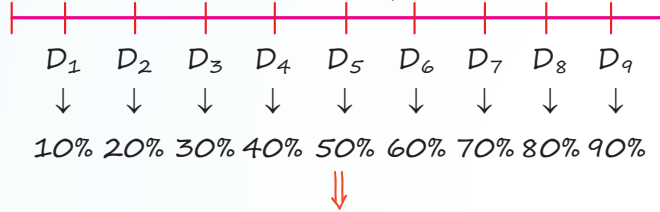

5^{th} Decile = D_5 = Median

For Individuals and Discrete series:

$$D_1 = \left(\frac{n+1}{10} \right)^{\text{th}} \text{ term}$$

$$D_2 = \left[2 \left(\frac{n+1}{10} \right) \right]^{\text{th}} \text{ term}$$

$$D_k = \left[k \left(\frac{n+1}{10} \right) \right]^{\text{th}} \text{ term}$$

In continuous series:

For D_1	For D_3
• Locate $\frac{N}{10}$ in CF	• Locate $\frac{3N}{10}$ in CF
• Select D_1 class	• Select D_3 class
• $D_1 = l + \left[\frac{\frac{N}{10} - CF}{F} \right] \times h$	• $D_3 = l + \left[\frac{\frac{3N}{10} - CF}{F} \right] \times h$

Percentiles ($P_1, P_2 \dots P_{99}$)

Divides entire series in 100 parts:

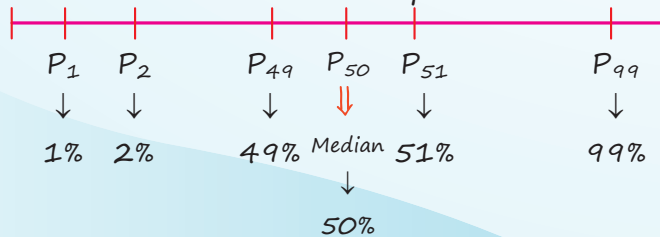

For Individuals and Discrete series:

$$P_1 = \left(\frac{n+1}{100} \right)^{\text{th}} \text{ term}$$

$$P_6 = \left[6 \left(\frac{n+1}{100} \right) \right]^{\text{th}} \text{ term}$$

$$P_k = \left[k \left(\frac{n+1}{100} \right) \right]^{\text{th}} \text{ term}$$

In continuous series:

For P_1	For P_7
• Locate $\frac{N}{100}$ in CF	• Locate $\frac{7N}{100}$ in CF
• Select P_1 class	• Select P_7 class
• $P_1 = l + \left[\frac{\frac{N}{100} - CF}{F} \right] \times h$	• $P_7 = l + \left[\frac{\frac{7N}{100} - CF}{F} \right] \times h$

Mode

An observation with highest frequency.

Individual series :

e.g.

Marks: 2,1,3,1,4,3,2,3,5,2,3,1,3,1,3,5,3,4,3

Mode: 3

Discrete series:

e.g.

x_i	f_i
2	6
3	12
4	3
5	5

\rightarrow Mode = 3

For continuous series:

□ Check the class interval with highest frequency (It is modal class)

□ Use formula :

$$\text{Mode} = l + \left[\frac{f_1 - f_0}{2f_1 - f_2 - f_0} \right] \times h$$

Note : Mode also changes with change of origin or change in scale.

i.e. $y = a + bx$

Then, mode of $y = a + b$ (mode of x)

GEOMETRIC MEAN

n^{th} Root of the product of n observations.

For Individual series :

$$GM = (x_1 \times x_2 \times \dots \times x_n)^{1/n}$$

Use for

- Average dep.
- Average of %

For Discrete and Continuous series :

$$GM = \left[(x_1)^{f_1} \times (x_2)^{f_2} \times \dots \times (x_n)^{f_n} \right]^{\frac{1}{N}}$$

Properties :

1. If all items are same (Let k) then $GM = K$

2. $\log(GM) = \frac{\sum \log x_i}{N}$

3. $GM(xy) = GM(x) \times GM(y)$

$$GM = AL \left[\frac{\sum \log x_i}{N} \right]$$

4. $GM\left(\frac{x}{y}\right) = \frac{GM(x)}{GM(y)}$

5. Combined Geometric Mean

$$G = \left[(G_1)^{N_1} \times (G_2)^{N_2} \right]^{\frac{1}{N_1+N_2}}$$

HARMONIC MEAN

Use for

- Average speed
- Average of rates

Reciprocal of Average of Reciprocal of all 'N' observations

- Find reciprocal of all items.
- Find average of these reciprocals.
- Find reciprocal of average.

Measures of Central Tendency and Dispersion

For Individual series:

$$HM = \frac{N}{\frac{1}{x_1} + \frac{1}{x_2} + \dots + \frac{1}{x_n}} = \frac{N}{\sum \left(\frac{1}{x_i} \right)}$$

For Discrete and Continuous series:

$$HM = \frac{N}{\sum \left(\frac{f_i}{x_i} \right)}$$

Properties:

1. If all items are same (let K) then $HM = K$

2. Combined $HM = \frac{N_1 + N_2}{\frac{N_1}{H_1} + \frac{N_2}{H_2}}$

Relation between AM, GM and HM

$$AM \geq GM \geq HM$$

If all items are different

$$AM > GM > HM$$

For any two items a & b

$$AM \times HM = GM^2$$

Weighted AM = $\frac{\sum w_i x_i}{\sum w_i}$

Weighted HM = $\frac{\sum w_i}{\sum \left(\frac{w_i}{x_i} \right)}$

Weighted GM = $AL \left[\frac{\sum w_i \log x_i}{\sum w_i} \right]$

DISPERSION

Statistical technique to find degree consistency (or variability) in all the observation.



• Low dispersion

• High dispersion

- Concentrated data
- Scattered data
- Less variability
- More variability
- More consistency
- Less consistency

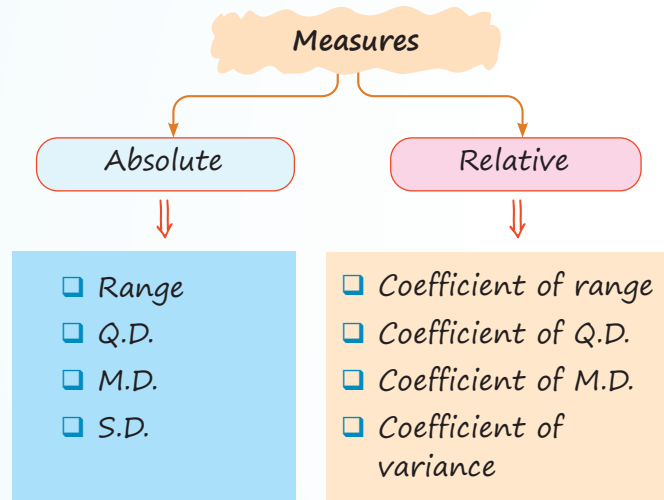

Range

Difference between largest and smallest observation:

$$R_x = L - S$$

$$\text{Coefficient of range} = \frac{L - S}{L + S} \times 100$$

- Range does not change with origin.
- Range changes with scale.

If $y = a + b + x$
 then, $R_y = |b| \times R_x$

QUARTILE DEVIATIONS

- Interquartile range = $Q_3 - Q_1$
- Semi quartile range (Quartile deviation) = $\frac{Q_3 - Q_1}{2}$
- Coefficient of Q.D. = $\frac{Q_3 - Q_1}{Q_3 + Q_1} \times 100$

or $\frac{\text{Q.D.}}{\text{Median}} \times 100$

(Only for symmetrical distribution)

- QD does not change with origin.
- QD changes with scale.

$$y_i = a + bx$$

$$\text{QD of } y = |b| \times \text{QD of } x$$

MEAN DEVIATION (MD)

Average of absolute deviations taken from mean, median or mode.

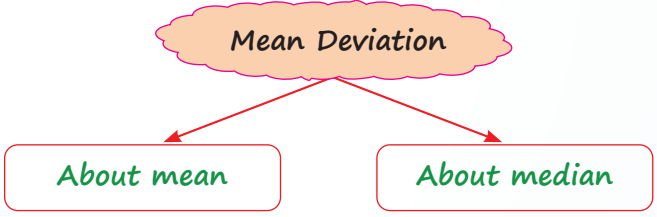

$$MD_{\bar{x}} = \frac{\sum f_i |x_i - \bar{X}|}{N}$$

$$MD_M = \frac{\sum f_i |x_i - m|}{N}$$

Coefficient of M.D. = $\frac{MD}{\text{Mean}} \times 100$
 or $\frac{MD}{\text{Median}} \times 100$

- MD does not change with origin.
- MD changes with scale

If $y = a + bx$
 then $MD_y = |b| \times MD_x$

STANDARD DEVIATION AND VARIANCE

Variance = σ^2

S.D. = σ

S.D. = $\sqrt{\text{Variance}}$

Variance = $(\text{S.D.})^2$

S.D. (σ) = $\sqrt{\frac{\sum f_i (x_i - \bar{X})^2}{N}}$

S.D. = $\sqrt{\frac{\sum f_i x_i^2}{N} - \left(\frac{\sum f_i x_i}{N}\right)^2}$

$$\square \text{ S.D.} = \sqrt{\frac{\sum f_i d_i^2}{N} - \left(\frac{\sum f_i d_i}{N}\right)^2}$$

where $d_i = x_i - A$

$$\square \text{ S.D.} = \sqrt{\frac{\sum f_i u_i^2}{N} - \left(\frac{\sum f_i u_i}{N}\right)^2} \times h$$

where $\frac{x_i - A}{h} = u_i$

□ S.D. does not change with origin.

□ S.D. change with change of scale.

If $y_i = a + bx$

S.D. of $y_i = |b| \times \text{S.D. of } x$

Variance of $y_i = b^2 \times \text{variance of } x$

Coefficient of variance = $\frac{\sigma}{\bar{X}} \times 100$



will be used for consistency and variability.

Higher CV → Higher variability

Lesser CV → Higher consistency.

□ S.D. of first 'n' natural number

$$= \sqrt{\frac{n^2 - 1}{12}}$$

□ S.D. of first 'n' even natural number

$$= \sqrt{\frac{n^2 - 1}{3}}$$

□ S.D. of first 'n' odd natural number

$$= \sqrt{\frac{n^2 - 1}{3}}$$

□ S.D. of two numbers a and b

$$= \frac{|a - b|}{2}$$

□ Q.D. : M.D. : S.D. = 10 : 12 : 15

$$\frac{QD}{MD} = \frac{10}{12} \quad \left| \quad \frac{MD}{SD} = \frac{12}{15} \quad \right| \quad \frac{QD}{SD} = \frac{10}{15}$$

□ Combined S.D.

$$= \sqrt{\frac{N_1(\sigma_1^2 + d_1^2) + N_2(\sigma_2^2 + d_2^2)}{N_1 + N_2}}$$

where, $d_1 = \bar{X}_{12} - \bar{X}_1$

$d_2 = \bar{X}_{12} - \bar{X}_2$

and, $\bar{X}_{12} = \frac{N_1 \bar{X}_1 + N_2 \bar{X}_2}{N_1 + N_2}$

QUESTIONS

Central Tendency

1. If mean of 5 observations $x + 1, x + 3, x + 5, x + 7$ and $x + 9$ is given 15, then the value of x will be

[PYQ-Dec., 2023]

- (a) 10 (b) 12
(c) 8 (d) 11

2. The mean of first three terms is 17 and mean of next four terms is 21. Calculate the seven terms.

[PYQ-Dec., 2023]

- (a) 18.28 (b) 19.78
(c) 19.58 (d) 19.28

3. The algebraic sum of deviations of set of observations from their arithmetic mean is

[PYQ-Jan., 2025]

(a) $\sqrt{\frac{\sum (x_i - \bar{x})^2}{n-1}}$

(b) $\frac{\sum x_i}{n}$

(c) $\frac{\sum x_i}{n-1}$

(d) Zero

4. The mean of a set of 20 observations is 18.3. The mean is reduced by 0.6 when a new observation is added to the set, then the new observation is

[MTP-Sep., 2024]

- (a) 17.6 (b) 18.0
(c) 5.7 (d) 24.6

5. The mean of three numbers is 135. Among the three numbers, the biggest number is 180. The difference between the remaining two numbers is 25, then the smallest number is

[PYQ-Jan., 2025]

- (a) 125 (b) 130
(c) 120 (d) 100

6. The mean of 50 observations is 36. If two observations 30 and 42 are to be excluded, then the mean of the remaining observation will be

[PYQ-Dec., 2022]

- (a) 36 (b) 38
(c) 48 (d) 50

7. The mean salary of a group of 50 persons is Rs. 5850. Later on it discovered that the salary of one has been wrongly taken as Rs. 8000 instead of Rs. 7800. The corrected mean salary is

[MTP-Sep., 2024]

- (a) Rs. 5854 (b) Rs. 5846
(c) Rs. 5640 (d) None

8. A Professor has given assignment to students in a Statistics class. A student Jagan computes the arithmetic mean and standard deviation for a set of 100 observations as 50 and 5 respectively. Later on, Sonali points out to Jagan that he has made a mistake in taking one observation as 100 instead of 50. What would be the correct mean if the wrong observation is corrected?

[PYQ-Jun, 2023]

- (a) 50.5 (b) 49.9
(c) 49.5 (d) 50.1

9. Find the Harmonic mean of 2, 4, and 6.

[PYQ-Jan, 2025]

- (a) 3.00 (b) 3.30
(c) 3.75 (d) 4.00

10. The Geometric Mean of 3, 7, 11, 15, 24, 28, 30, 0 is

[PYQ-Jun, 2023]

- (a) 6 (b) 0
(c) 9 (d) 12

11. If the AM and GM for two numbers are 6.50 and 6 respectively, then the two numbers are

[PYQ-May, 2025]

- (a) 6 and 7 (b) 9 and 4
(c) 10 and 3 (d) 8 and 5

12. The AM and HM of two numbers are 5 and 3.2 respectively, then GM will be

[PYQ-Dec, 2023]

- (a) 4.4 (b) 4.2
(c) 4.0 (d) 3.8

13. An aeroplane flies from A to B at the rate of 500 km/hr and comes back from B to A at the rate of 700 km/hr. The average speed of the aeroplane is:

[PYQ-May, 2025]

- (a) 600 km/hr
(b) 583.33 km/hr
(c) $100\sqrt{35}$ km/hr
(d) 620 km/hr

14. A train covered the first 5 km of its journey at a speed of 30 km/hr and next 15 km at a speed of 45 km/hr. The average speed of the train was

[PYQ-Dec. 2022]

- (a) 38 km/hr (b) 40 km/hr
(c) 36 km/hr (d) 42 km/hr

15. The geometric mean of three numbers 40, 50 and x is 10, the value of x is

[PYQ-Dec. 2022]

- (a) 5 (b) 4
(c) 2 (d) $1/2$

16. The Harmonic mean H of two numbers is 4 and their arithmetic means A and the geometric mean G satisfy the equation $2A + G^2 = 27$ the numbers are

[MTP-Sep. 2024]

- (a) (1, 3) (b) (9, 5)
(c) (6, 3) (d) (12, 7)

Median

17. Which of the following measure of central tendency depends on the position of the observation?

[PYQ-June, 2024]

- (a) Mean (b) Median
(c) Mode (d) Harmonic Mean

18. Which one of the following measures of central tendency is based on only fifty percent (50%) of the central values?

[PYQ-May, 2025]

- (a) Geometric Mean (b) Harmonic Mean
(c) Median (d) Mode

19. For open-end classification, which of the following is the best measure of central tendency?

[PYQ-June. 2024]

- (a) AM (b) GM
(c) Median (d) Mode

20. If two variable x and y are related as $2x - y = 3$. If the median of x is 10, what is the median of y ?

[PYQ-Dec. 2023]

- (a) 4 (b) 17
(c) 5 (d) 6

21. The median of the observations 42, 72, 35, 92, 67, 85, 72, 81, 51, 56 is

[PYQ-Dec. 2022]

- (a) 69.5 (b) 72
(c) 64 (d) 61.5

22. The median of the following numbers, which are given in ascending order is 25. Find the value of x . 11, 13, 15, 19, $(x + 2)$, $(x + 4)$ 30, 35, 39, 46

[MTP-Sep. 2024]

- (a) 22 (b) 20
(c) 15 (d) 30

23. The third decile for the values of 8, 24, 21, 10, 14, 11, 19, 16 is

[MTS-May. 2025]

- (a) 7.2 (b) 9.5
(c) 10.7 (d) 12

24. The first quartile is 142 and semi-interquartile range is 18, then the value of median is

[MTP-Sep. 2024]

- (a) 151 (b) 160
(c) 178 (d) None of these

Mode

25. Find out the mode from the following data:

100, 110, 125, 225, 325, 125, 90, 80, 455, 375, 125

[PYQ-May, 2025]

- (a) 325 (b) 110
(c) 455 (d) 125

26. If the mode of the following data is 13, then the value of x in the dataset is

13, 8, 6, 3, 8, 13, $2x + 3$, 8, 13, 3, 5, 7

[PYQ-Jan. 2025]

- (a) 5 (b) 6
(c) 7 (d) 8

Relation between Mean, Median and Mode

27. If mean of the data is 10 and its median is 9, then the value of mode will be

[MTS-May, 2025]

- (a) 4 (b) 7
(c) 8 (d) 10

28. If mode of a grouped data is 10 and median is 6, then what is the value of mean ?

[PYQ-Dec. 2023]

- (a) 2 (b) 4
(c) 6 (d) 8

29. The Arithmetic Mean (A.M.) and Mode of the data are 32 and 26 respectively, then find the median of the data.

[PYQ-May, 2025]

- (a) 30 (b) 12
(c) 6 (d) 29

30. If the mode of a data is 18 and mean is 24, then median is

[MTP-Sep. 2024]

- (a) 18 (b) 24
(c) 22 (d) 21

31. For a moderately skewed distribution of marks in Statistics for a group of 200 students, the mean marks and median marks were found to be 55.60 and 52.40 respectively. What are the modal marks?

[PYQ-June, 2023]

- (a) 55.43 (b) 48
(c) 53.36 (d) 46

32. If the difference between Mean and Mode is 69, then the difference between Mean and Median will be

[PYQ-Dec. 2022]

- (a) 63 (b) 31.5
(c) 23 (d) None

Dispersion

33. Which measure of dispersion is based on the absolute deviations only?

[PYQ-Dec. 2022]

- (a) Range
(b) Standard deviation
(c) Mean deviation
(d) Quartile deviation

34. Which one of the following is the absolute measure of dispersion for open ended distribution?

[PYQ-May. 2025]

- (a) Range (b) Standard deviation
(c) Mean deviation (d) Quartile deviation

35. If x and y are related as $4x + 2y + 12 = 0$ and mean deviation of x is 4.5, then the mean deviation of y is [PYQ-Jan. 2025]

- (a) 9 (b) -9
(c) 1.1 (d) 4.5

36. The quartiles of a variable are 45, 52 and 65 respectively. Its quartile deviation is [MTP-Sep. 2024]

- (a) 10 (b) 20
(c) 25 (d) 8.30

37. If the quartile deviation is 12 and the first quartile is 25, then the value of the third quartile is [PYQ-Dec. 2023]

- (a) 37 (b) 49
(c) 61 (d) 60

38. If the quartile deviation of x is 8 and $3x + 6y = 20$, then the quartile deviation of y is [MTP-May. 2025]

- (a) 4 (b) 3
(c) 5 (d) None of these

39. If the variables x and y are related by $3y = -2x - 4$ and SD of y is 4, then SD of x is [MTS-May. 2025]

- (a) 2 (b) 4
(c) 6 (d) -6

40. If x and y are related as $3x - 4y = 20$, and the quartile deviation of x is 12, then the quartile deviation of y is [MTP-Sep. 2024]

- (a) 14 (b) 15
(c) 16 (d) 9

41. Origin is shifted by 5, what will happen? [MTP-Sep. 2024]

- (a) SD will increase by 5
(b) QD will increase by 5
(c) MD will increase by 5
(d) There will be no change in SD

42. For the first 20 natural numbers, the standard deviation is [PYQ-Jun. 2024]

- (a) 5.77 (b) 7.75
(c) 5.64 (d) 6.54

43. If $2x + 3y + 4 = 0$ and $v(x) = 6$, then $v(y)$ is [PYQ-Dec. 2022]

- (a) $8/3$ (b) 9
(c) -9 (d) 6

44. Consider the data sets; $X = \{-6, 2, -2, 6\}$, $Y = \{4, 8, 2, 6\}$ and $Z = \{103, 100, 102, 101\}$. Let S_x , S_y & S_z be the standard deviations of the sets X , Y and Z respectively. We have the relations, [PYQ-Jun. 2024]

- (a) $S_x < S_y < S_z$ (b) $S_z < S_y < S_x$
(c) $S_z < S_x < S_y$ (d) $S_x < S_z < S_y$

Relative Measure of Dispersion

45. The coefficient of the range of the data :

7, 8, 4, 1, 9, 12, 18, 16, 94, 3, 5, -6 is

[PYQ-June, 2024]

- (a) 133.6 (b) 163.3
(c) 166.3 (d) 113.6

46. The monthly profit/loss for six months of the firm is as under:

Months	Profit/Loss (in ₹)
January	1000
February	900
March	0
April	-200
May	-400
June	2000

The coefficient of Range of the above data is

[PYQ-May, 2025]

- (a) 122 (b) 150
(c) 33.33 (d) 55.55

47. In a dataset, 25 percent of values are smaller than 30 and one-fourth of values are larger than 70, then the coefficient of quartile deviation is _____%. [PYQ-Jun. 2024]

- (a) 40 (b) 50
(c) 60 (d) 70

48. If x and y are related by $y = 2x + 5$ and SD and AM of x are known to be 5 and 10 respectively, then the coefficient of variation of y is [MTP-Sep. 2024]

- (a) 25 (b) 30
(c) 40 (d) 20

49. The arithmetic mean and coefficient of variation of data set x are respectively 10 and 30. The variance of $30 - 2x$ is [PYQ-Dec. 2022]

- (a) 28 (b) 32
(c) 34 (d) 36

ANSWER KEY

- | | | | | | | | | | |
|---------|---------|---------|---------|---------|---------|---------|---------|---------|---------|
| 1. (a) | 2. (d) | 3. (d) | 4. (c) | 5. (d) | 6. (a) | 7. (b) | 8. (c) | 9. (b) | 10. (b) |
| 11. (b) | 12. (c) | 13. (b) | 14. (b) | 15. (d) | 16. (c) | 17. (b) | 18. (b) | 19. (c) | 20. (b) |
| 21. (a) | 22. (a) | 23. (c) | 24. (b) | 25. (d) | 26. (a) | 27. (b) | 28. (b) | 29. (a) | 30. (c) |
| 31. (d) | 32. (c) | 33. (c) | 34. (d) | 35. (a) | 36. (a) | 37. (b) | 38. (a) | 39. (c) | 40. (d) |
| 41. (d) | 42. (a) | 43. (a) | 44. (b) | 45. (d) | 46. (b) | 47. (a) | 48. (c) | 49. (d) | |

HINTS & SOLUTIONS

1. (a) Given: Mean of 5 observations $x + 1, x + 3, x + 5, x + 7$ and $x + 9$ is given 15

$$\text{i.e., } \frac{x+1+x+3+x+5+x+7+x+9}{5} = 15$$

$$\Rightarrow \frac{5x+25}{5} = 15$$

$$\Rightarrow 5x + 25 = 75$$

$$\Rightarrow 5x = 50$$

$$\Rightarrow x = 10$$

2. (d) Given; mean of first three terms is 17 and mean of next four terms is 21

$$\text{i.e., Sum of first three terms} = 17 \times 3$$

$$\text{And, sum of next four terms} = 21 \times 4$$

$$\text{Therefore, Mean of seven terms} = \frac{3 \times 17 + 4 \times 21}{7} = 19.28$$

3. (d) We know that,

The algebraic sum of deviations of set of observations from their arithmetic mean is zero.

$$\text{i.e., } \sum (x_i - \bar{x}) = 0.$$

4. (c) Given, Mean of a set of 20 observations = 18.3

$$\bar{x} = \frac{\sum x}{n}$$

$$\Rightarrow 18.3 = \frac{\sum x}{20}$$

$$\Rightarrow \sum x = 366$$

Now, let the new observation added be m , then

$$18.3 - 0.6 = \frac{366+m}{21}$$

$$\Rightarrow 17.7 = \frac{366+m}{21}$$

$$\Rightarrow m = 5.7$$

5. (b) Let the three numbers be $a, b, 180$.

According to question,

$$\frac{a+b+180}{3} = 135$$

$$\Rightarrow a + b + 180 = 405$$

$$\Rightarrow a + b = 225 \quad \dots(i)$$

$$\text{Also, } b - a = 25 \quad \dots(ii)$$

From (i) and (ii), we get

$$2b = 250$$

$$\Rightarrow b = 125$$

$$\text{Thus, } a = 10$$

Hence, the smallest number is 100.

6. (a) Given, Mean of 50 observations = 36

$$\text{i.e., } \bar{x} = \frac{\sum x}{n}$$

$$\Rightarrow \sum x = 36 \times 50 = 1800$$

Now, two observations 30 and 42 are excluded, then the mean of remaining observations can be calculated as:

$$\sum x = 1800 - 30 - 42 = 1728$$

$$\Rightarrow \text{Mean} = \frac{1728}{48} = 36$$

7. (b) Given, Mean salary of a group of 50 persons = Rs. 5850

$$\text{Incorrect observation} = \text{Rs. } 8000$$

$$\text{Correct observation} = \text{Rs. } 7800$$

$$\Rightarrow \sum x = 50 \times 5850 - 8000 + 7800$$

$$\Rightarrow \Sigma x = 292300$$

$$\text{Therefore, new mean} = \frac{292300}{50} = \text{Rs. } 5846$$

8. (c) According to question, we have

$$n = 100, \bar{x} = 50 \text{ and } \sigma = 5$$

$$\Rightarrow \Sigma x_{\text{incorrect}} = 100 \times 50 = 5000$$

$$\Rightarrow \Sigma x_{\text{correct}} = 5000 - 100 + 50 = 4950$$

$$\Rightarrow \text{Correct mean} = \frac{4950}{100}$$

$$\Rightarrow \text{Correct mean} = 49.5$$

9. (b) Harmonic mean of 2, 4 and 6 is given by

$$\text{H.M.} = \frac{3}{\frac{1}{2} + \frac{1}{4} + \frac{1}{6}}$$

$$\Rightarrow \text{H.M.} = 3.27 = 3.30 \text{ (approx)}$$

10. (b) We know,

Geometric Mean is given by

$$\begin{aligned} & (a_1 \times a_2 \times \dots \times a_n)^{1/n} \\ & = (3 \times 7 \times 11 \times 15 \times 24 \times 28 \times 30 \times 0)^{1/8} \\ & = (0)^{1/8} \\ & = 0 \end{aligned}$$

11. (b) If a and b are two positive observations such that $a > b$, then according to the question

$$\frac{a+b}{2} = 6.5 \quad (\because AM = 6.5)$$

$$a + b = 13 \quad \dots(i)$$

$$\text{and } \sqrt{ab} = 6 \quad (\because GM = 6)$$

$$ab = 36$$

$$\because (a - b)^2 = (a + b)^2 - 4ab$$

$$(a - b)^2 = (13)^2 - 4 \times 36$$

$$(a - b)^2 = 169 - 144$$

$$(a - b)^2 = 25$$

$$a - b = 5 \quad \dots(ii)$$

Adding (i) and (ii), we get

$$2a = 18$$

$$a = 9$$

From (i), we get

$$b = 13 - 9 = 4$$

Therefore, the two numbers are 9 and 4.

12. (c) We know,

$$GM^2 = AM \times HM$$

$$\Rightarrow GM^2 = 5 \times 3.2$$

$$\Rightarrow GM = \sqrt{5 \times 3.2}$$

$$\Rightarrow GM = 4.0$$

13. (b)

Speed of the aeroplane from A to B

$$= 500 \text{ km/hr}$$

Speed of the aeroplane from B to A

$$= 700 \text{ km/hr}$$

By using the formula, average speed = $\frac{2xy}{x+y}$

[where x and y are speeds for same distances]

$$\Rightarrow \text{Average speed} = \frac{2 \times 500 \times 700}{500 + 700}$$

$$\Rightarrow \text{Average speed} = 583.33 \text{ km/hr}$$

Therefore, the average speed of the aeroplane is 583.33 km/hr

14. (b) We know that,

$$\text{Speed} = \frac{\text{Distance}}{\text{Time}}$$

$$\text{Thus, average speed} = \frac{\text{Total Distance}}{\text{Total Time}}$$

$$\Rightarrow \frac{5+15}{\frac{5}{30} + \frac{15}{45}} \quad \Rightarrow \frac{20}{\frac{1}{6} + \frac{1}{3}}$$

$$\Rightarrow \frac{20 \times 6}{3}$$

$$\Rightarrow 40 \text{ km/hr}$$

15. (d) Given, Geometric mean of three numbers

40, 50 and $x = 10$

$$\text{i.e., } (40 \times 50 \times x)^{1/3} = 10$$

Taking cube on both sides, we get

$$2000x = 10^3$$

$$\Rightarrow 2000x = 1000$$

$$\Rightarrow x = \frac{1}{2}$$

16. (c) Given: $2A + G^2 = 27$

$$\text{We know, } H = \frac{2ab}{a+b} = 4$$

Go by options:

For option (A): (1, 3)

$$\Rightarrow H = \frac{2 \times 1 \times 3}{4} = \frac{3}{2}, \text{ not true}$$

For option (B): (9, 5)

$$\Rightarrow H = \frac{2 \times 9 \times 5}{14} = \frac{45}{7}, \text{ not true}$$

For option (C): (6, 3)

$$\Rightarrow H = \frac{2 \times 6 \times 3}{9} = 4, \text{ which is true}$$

For option (D): (12, 7)

$$\Rightarrow H = \frac{2 \times 12 \times 7}{19} = \frac{168}{19}$$

$$\text{Also, for } (6, 3): A = \frac{6+3}{2} = \frac{9}{2} \text{ and } G = \sqrt{6 \times 3} = \sqrt{18}$$

$$\text{Thus, } 2A + G^2 = 2 \left(\frac{9}{2} \right) + (\sqrt{18})^2 = 27$$

It satisfy the given relation.

Hence, the numbers are 6 and 3.

17. (b) We know,

Median depends on the position of the observation whereas mean is the average of all the observations and Mode is the value that occur maximum number of times.

18. (b) We have,

Median is based on only fifty percent (50%) of the central values.

19. (c) We know,

For open-end classification, Median is the best measure of central tendency.

20. (b) Given, Two variable x and y are related as

$$2x - y = 3$$

$$\Rightarrow 2x_{\text{med}} - y_{\text{med}} = 3$$

$$\Rightarrow 2(10) - y_{\text{med}} = 3$$

$$\Rightarrow y_{\text{med}} = 17$$

21. (a) Given observations :

42, 72, 35, 92, 67, 85, 72, 81, 51, 56

Arranging the observations in ascending order, we get

35, 42, 51, 56, 67, 72, 72, 81, 85, 92

Here, number of observations (n) = 10, which is even.

Thus, Median = Average of two middle terms

$$\Rightarrow \text{Median} = \frac{67+72}{2} = \frac{139}{2} = 69.5$$

Therefore, median of given observations is 69.5

22. (a) Given observations :

11, 13, 15, 19, $(x + 2)$, $(x + 4)$, 30, 35, 39, 46

Here, $n = 10$

$$\text{Thus, Median} = \frac{5^{\text{th}} \text{ term} + 6^{\text{th}} \text{ term}}{2}$$

$$\Rightarrow 25 = \frac{x+2+x+4}{2}$$

$$\Rightarrow 50 = 2x + 6 \Rightarrow x = 22$$

23. (c) Arranging the given data in ascending order, we get

8, 10, 11, 14, 16, 19, 21, 24

$$D_3 = 3 \left(\frac{8+1}{10} \right)^{10} \text{ term}$$

$$\Rightarrow D_3 = 3(0.9)^{\text{th}} \text{ term}$$

$$\Rightarrow D_3 = 2.7^{\text{th}} \text{ term}$$

$$\Rightarrow D_3 = 2^{\text{nd}} + 0.7 (3^{\text{rd}} - 2^{\text{nd}})$$

$$\Rightarrow D_3 = 10 + 0.7 (11 - 10)$$

$$\Rightarrow D_3 = 10 + 0.7 \Rightarrow D_3 = 10.7$$

24. (b) Given; First quartile = 142 and

Semi-interquartile range = 18

$$\Rightarrow \frac{Q_3 + Q_1}{2} = 18$$

$$\Rightarrow Q_3 - 142 = 36$$

$$\Rightarrow Q_3 = 178$$

$$\Rightarrow Q_2 = \frac{Q_3 + Q_1}{2}$$

$$\Rightarrow Q_2 = \frac{178 + 142}{2} \Rightarrow Q_2 = 160$$

25. (d) Given data : 100, 110, 125, 225, 325, 125, 90, 80, 455, 375, 125

Here, 125 appears thrice.

Therefore, the mode of the data is 125.

26. (a) Given dataset :

13, 8, 6, 3, 8, 13, $2x + 3$, 13, 3, 5, 7

Since, 8 and 13 are repeating thrice and 13 is the given mode.

Therefore, the value of $2x + 3$ should be equal to 13 to the mode be 13.

$$\text{i.e., } 2x + 3 = 13 \text{ or } x = 5.$$

27. (b) Given, Mean = 10 and Median = 9

We know,

$$\text{Mean} - \text{Mode} = 3 \text{ (Mean} - \text{Median)}$$

$$\begin{aligned} \Rightarrow 10 - \text{Mode} &= 3(10 - 9) \\ \Rightarrow 10 - \text{Mode} &= 3(1) \\ \Rightarrow \text{Mode} &= 10 - 3 \Rightarrow \text{Mode} = 7 \end{aligned}$$

28. (b) We know,

$$\text{Mean} - \text{Mode} = 3 \text{ Mean} - 3 \text{ Median}$$

$$\Rightarrow \text{Mean} = \frac{3 \text{ Median} - \text{Mode}}{2}$$

$$\Rightarrow \text{Mean} = \frac{3(6) - 10}{2} \Rightarrow \text{Mean} = 4$$

29. (a) Given, Mean = 32 and Mode = 26

We know,

$$\text{Mean} - \text{Mode} = 3(\text{Mean} - \text{Median})$$

$$\Rightarrow 32 - 26 = 3(32 - \text{Median})$$

$$\Rightarrow \frac{6}{3} = 32 - \text{Median}$$

$$\Rightarrow \text{Median} = 32 - 2 = 30$$

30. (c) We know,

$$\text{Mean} - \text{Mode} = 3(\text{Mean} - \text{Median})$$

$$24 - 18 = 3(24 - \text{Median})$$

$$\text{Median} = 22$$

31. (d) Given, Mean = 55.60 and Median = 52.40

We know,

$$\text{Mode} = 3 \text{ Median} - 2 \text{ Mean}$$

$$\Rightarrow \text{Mode} = 3(52.40) - 2(55.60)$$

$$\Rightarrow \text{Mode} = 46$$

32. (c) We know that,

$$\text{Mean} - \text{Mode} = 3(\text{Mean} - \text{Median})$$

$$\Rightarrow 69 = 3(\text{Mean} - \text{Median})$$

$$\Rightarrow \frac{69}{3} = \text{Mean} - \text{Median}$$

$$\Rightarrow \text{Mean} - \text{Median} = 23$$

33. (c) We know that,

M.D = $\Sigma |x_i - \bar{x}|$, which gives the absolute deviations only.

Therefore, Mean deviation is based on the absolute deviations only.

34. (d) We know,

Quartile deviation is the absolute measure of dispersion for open ended distribution.

35. (a) Given, x and y are related as $4x + 2y + 12 = 0$

$$\Rightarrow 2y = -4x - 12$$

$$\Rightarrow y = -2x - 6$$

We know,

Mean deviation remains unchanged due to change in origin but changes in same ratio due to a change in scale. Thus, mean deviation of y is given by

$$M.D_y = |-2| \times M.D_x$$

$$\Rightarrow M.D_y = 2 \times 4.5 \Rightarrow M.D_y = 9$$

36. (a) We know,

$$\text{Quartile deviation} = \frac{Q_3 - Q_1}{2}$$

$$= \frac{65 - 45}{2} = \frac{20}{2} = 10$$

37. (b) Given; Quartile deviation is 12 and the first quartile is 25

We know,

$$Q.D = \frac{Q_3 - Q_1}{2}$$

$$\Rightarrow 12 = \frac{Q_3 - 25}{2}$$

$$\Rightarrow Q_3 - 25 = 24 \Rightarrow Q_3 = 49$$

38. (a) Given,

$$\text{Relation between } x \text{ and } y \text{ is } 3x + 6y = 20$$

$$\Rightarrow 6y = -3x + 20$$

$$\Rightarrow y = -\frac{3}{6}x + \frac{20}{6}$$

$$\Rightarrow y = -\frac{1}{2}x + \frac{10}{3}$$

Therefore, quartile deviation of y is given by

$$Q.D_y = \left| -\frac{1}{2} \right| \times Q.D_x$$

$$\Rightarrow Q.D_y = \frac{1}{2} \times 8$$

$$\Rightarrow Q.D_y = 4$$

39. (c) Given, $3y = -2x - 4$

$$\Rightarrow 2x = -3y - 4$$

$$\Rightarrow x = -\frac{3y}{2} - 2$$

$$\Rightarrow S.D_x = \left| -\frac{3}{2} \right| \times S.D_y$$

$$\Rightarrow S.D_x = \frac{3}{2} \times 4$$

$$\Rightarrow S.D_x = 6$$

40. (d) Given, x and y are related as $3x - 4y = 20$

$$\Rightarrow y = \frac{3}{4}x - 5$$

$$\Rightarrow Q.D_y = \left| \frac{3}{4} \right| \times Q.D_x$$

$$\Rightarrow Q.D_y = \left| \frac{3}{4} \right| \times 12 \Rightarrow Q.D_y = 9$$

41. (d) We know,

There is no effect on SD, MD and QD on the shifting of origin.

Therefore, there will be no change in SD if origin gets shifted by 5.

42. (a) We know that,

Standard deviation of first n natural numbers is given by

$$S.D. = \sqrt{\frac{n^2 - 1}{12}}$$

Here, $n = 20$

Therefore,

$$S.D. = \sqrt{\frac{20^2 - 1}{12}} = \sqrt{\frac{199}{12}} = 5.77 \text{ (approx)}$$

43. (a) Given, $2x + 3y + 4 = 0$

$$\Rightarrow 3y = -2x - 4$$

$$\Rightarrow y = -\frac{2x}{3} - \frac{4}{3}$$

Thus,

$$S.D._y = |b| S.D._x$$

$$\Rightarrow V(y) = b^2 \times V(x)$$

$$\Rightarrow V(y) = \left(\frac{2}{3}\right)^2 \times 6$$

$$\Rightarrow V(y) = \frac{4}{9} \times 6 \Rightarrow V(y) = \frac{8}{3}$$

44. (b) Given;

$$X = \{-6, -2, 2, 6\}$$

$$Y = \{2, 4, 6, 8\}$$

$$Z = \{100, 101, 102, 103\}$$

Clearly, the scatterness in the values is greater in dataset X , then Y and least in Z .

Therefore, $S_x > S_y > S_z$.

45. (d) Given data: 7, 8, 4, 1, 9, 12, 18, 16, 94, 3, 5, -6

Here, Largest observation = 94

Smallest observation = -6

Therefore,

$$\begin{aligned} \text{Coefficient of range} &= \frac{94 - (-6)}{94 + (-6)} \times 100 \\ &= \frac{100}{88} \times 100 = 113.6 \end{aligned}$$

46. (b) From the given data, we have

Largest value (L) = 2000

Smallest value (S) = -400

We know,

$$\text{Coefficient of Range} = \frac{L - S}{L + S} \times 100$$

$$= \frac{2000 - (-400)}{2000 + (-400)} \times 100$$

$$= \frac{2400}{1600} \times 100 = 150$$

47. (a) Given, 25 percent of values are smaller than 30 and one-fourth of values are larger than 70

i.e., $Q_1 = 30$ and $Q_3 = 70$

Thus, coefficient of quartile deviation

$$= \frac{Q_3 - Q_1}{Q_3 + Q_1} \times 100$$

$$= \frac{40}{100} \times 100 = 40$$

48. (c) Since, x and y are related by $y = 2x + 5$ thus

$$\bar{y} = 2\bar{x} + 5$$

$$\Rightarrow \bar{y} = 2(10) + 5$$

$$\Rightarrow \bar{y} = 25$$

$$\text{Now, } S.D_y = |2| S.D_x \Rightarrow S.D_y = 10$$

Therefore,

$$C.V_y = \frac{S.D_y}{\bar{y}} \times 100$$

$$\Rightarrow \frac{10}{25} \times 100 \Rightarrow 40$$

49. (d) Given, Mean = 10 and Coefficient of variation (C.V.) = 30

$$C.V. = \frac{S.D.}{\text{Mean}} \times 100$$

$$\Rightarrow 30 = \frac{S.D.}{10} \times 100 \Rightarrow S.D. = 3$$

Let $y = 30 - 2x$, then

$$S.D_y = |-2| \times S.D_x$$

$$\Rightarrow S.D_y = 2 \times 3 = 6$$

Therefore, variance of $(30 - 2x) = 6^2 = 36$.



Chapter Wrap-up Test

Ready to test your knowledge?

You've got 15 questions and 20 minutes - Go for it!

1. If the mode of the following data is 13, then the value of x in the dataset is
13, 8, 6, 3, 8, 13, $2x+3$, 8, 13, 3, 5, 7

(a) 5 (b) 6
(c) 7 (d) 8

2. The mean of first three terms is 17 and mean of next four terms is 21. Calculate the seven terms.

(a) 18.28 (b) 19.78
(c) 19.58 (d) 19.28

3. If mean of 5 observations $x + 1$, $x + 3$, $x + 5$, $x + 7$ and $x + 9$ is given 15, then the value of x will be

(a) 10 (b) 12
(c) 8 (d) 11

4. The median of the following numbers, which are given in ascending order is 25. Find the value of x .

11, 13, 15, 19, $(x + 2)$, $(x + 4)$ 30, 35, 39, 46

(a) 22 (b) 20
(c) 15 (d) 30

5. If the mode of a data is 18 and mean is 24, then median is

(a) 18 (b) 24
(c) 22 (d) 21

6. The mean of three numbers is 135. Among the three numbers, the biggest number is 180. The difference between the remaining two numbers is 25, then the smallest number is

(a) 125 (b) 130
(c) 120 (d) 100

7. Find the Harmonic mean of 2, 4 and 6.

(a) 3.00 (b) 3.30
(c) 3.75 (d) 4.00

8. Which of the following statements is true?

(a) Median is based on all observations
(b) Mode is the mid value
(c) Median is the 2nd Quartile
(d) Mode is the 5th decile

9. What is the coefficient of mean deviation for the following distribution of heights? Take deviation from AM.

Height in inches	No. of Students
60-62	5
63-65	22
66-68	28
69-71	17
72-74	3

(a) 2.30 inches
(b) 3.45 inches
(c) 3.82 inches
(d) 2.48 inches

10. If the quartile deviation is 12 and the first quartile is 25, then the value of the third quartile is

(a) 37 (b) 49
(c) 61 (d) 60

11. If x and y are related by $y = 2x + 5$ and SD and AM of x are known to be 5 and 10 respectively, then the coefficient of variation of y is

(a) 25 (b) 30
(c) 40 (d) 20

12. If two variables x and y are related by $2x + 3y - 7 = 0$ and the mean and mean deviation about mean of x are 1 and 0.3 respectively, then the coefficient of mean deviation of y about its mean is

(a) -5 (b) 12
(c) 50 (d) 4

13. The mean annual salary of all employees in a company is ₹25,000. The mean salary of male and female employees is ₹27,000 and ₹17,000 respectively. Find the percentage of males and females employed by the company

- (a) 60% and 40%
- (b) 70% and 25%
- (c) 70% and 30%
- (d) 80% and 20%

14. The third decile for the numbers 15, 10, 20, 25, 18, 11, 9, 12 is

- (a) 13
- (b) 10.70
- (c) 11
- (d) 11.50

15. A train covered the first 5 km of its journey at a speed of 30 km/hr and next 15 km at a speed of 45 km/hr. The average speed of the train was

- (a) 38 km/hr
- (b) 40 km/hr
- (c) 36 km/hr
- (d) 42 km/hr

ANSWER KEY

1. (a) 2. (d) 3. (a) 4. (a) 5. (c) 6. (d) 7. (b) 8. (c) 9. (b) 10. (b)
11. (c) 12. (b) 13. (d) 14. (b) 15. (b)



Cheat Sheet by Anurag Sir

Probability

“The chances of occurrence of an event is called probability.”

Subjective Probability

Based on opinions or belief

Objective Probability

Based on recorded observations (Data)

Probability of an event is denoted by $P(E)$

$$0 \leq P(E) \leq 1$$

$$P(E) + P(\text{not } E) = 1$$

$$P(\text{not } E) = 1 - P(E)$$

Random Experiment

Any experiment which can produce more than one possible outcomes and where the result can not be predicted.

e.g. Tossing a coin.

e.g. Throwing two dice together.

Sample Space

Set (collection) of all possible outcomes which are associated to a random experiment.

e.g. Coin tossed once

$$S = \{H, T\}$$

e.g. Dice is thrown once

$$S = \{1, 2, 3, 4, 5, 6\}$$

Event

It is a subset of sample space.

- Simple event: It contains only one element.
- Compound event: It contain more than one element.

e.g. A coin is tossed twice

$$S = \{HH, HT, TH, TT\}$$

$$\left[\begin{array}{l} E = \{HH\} \\ F = \{HT\} \end{array} \right]$$

Simple Events

$$\left[\begin{array}{l} G = \{HH, HT\} \\ H = \{HH, TT, TH\} \end{array} \right]$$

Compound Events

- Impossible event (Empty): It can never happen

$$P(E) = 0$$

- Sure event: It will definitely happen

$$P(E) = 1$$

e.g. $S = \{1, 2, 3, 4, 5, 6\}$

E: A number less than 7

$$= \{1, 2, 3, 4, 5, 6\}$$

Sure event

F: A number more than 7

$$= \{ \} = \phi$$

Impossible event

- Equally likely events: Two or more events with same probability.

e.g. Coin is tossed

$$P(H) = \frac{1}{2} \text{ and } P(T) = \frac{1}{2}$$

e.g. Dice is thrown

$$P(1) = P(2) = \dots P(6) = \frac{1}{6}$$

□ **Complementary events:** Not happening of an event is known as complementary event denoted by E' or \bar{E}

$$P(E) + P(\bar{E}) = 1$$

e.g. A coin tossed twice

$$S = \{HH, HT, TH, TT\}$$

E : Two heads = $\{HH\}$

E' or $\bar{E} = \{HT, TH, TT\}$

↙ This is compliment of E

Mutually Exclusive Events

When selection of one event results rejection of the events

Or

When two events can not happen simultaneously

Or

When two events have nothing in common

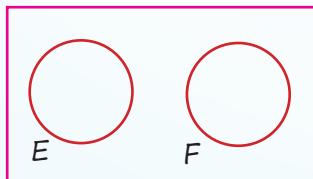

$$E \cap F = \phi$$

Mutually exclusive

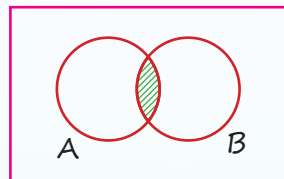

$$A \cap B \neq \phi$$

Not Mutually exclusive

e.g. A : Aman is voter of Delhi.

B : Aman is 14 years old.

Mutually Exclusive

e.g. E : Anita is good singer.

F : Anita speaks fluent english.

Not Mutually Exclusive

If two events are Mutually Exclusive

Then, $E \cap F = \phi$

$$P(E \cap F) = 0$$

Probability

Mutually Exhaustive Events

Two or more events are mutually exhaustive if their union makes sample space

i.e. $A \cup B = S \Rightarrow P(A \cup B) = 1$

e.g. $S = \{1, 2, 3, 4, 5, 6\}$

A : Even = $\{2, 4, 6\}$

B : Odd = $\{1, 3, 5\}$

$$A \cup B = S \quad \text{Mutually Exhaustive}$$

E : Prime = $\{2, 3, 5\}$

F : Odd = $\{1, 3, 5\}$

$$A \cup B = \{1, 2, 3, 5\} \neq S$$

Not Mutually Exhaustive

Classical (Priori) Definition of Probability

Assumes

- All outcomes are known.
- All outcomes are equally likely.
- All outcomes are mutually exclusive.

$$P(E) = \frac{\text{Total no. of Favorable outcomes}}{\text{Total no. of Possible outcomes}}$$

e.g. $S = \{1, 2, 3, 4, 5, 6\} \rightarrow$ Dice

$$P(\text{even}) = \frac{3}{6} = \frac{1}{2}$$

Relative Frequency Definition of Probability

Statistical Definition

$n \rightarrow$ No. of times an experiment is repeated

$n \rightarrow \infty$ (n is a big number)

$f_A \rightarrow$ An event 'A' is repeated f_A times

Then, Probability of event A

$$P(A) = \lim_{n \rightarrow \infty} \frac{f_A}{n}$$

Axiomatic (Modern) Definition of Probability

Axiom : Any rule which don't require proof.

Under this axiomatic approach.

- $P(A)$ is always non negative i.e., $P(A) \geq 0$
- Prob. of sample space is a sure event
i.e. $P(S) = 1$
- If A and B are Mutually exclusive
Then, $P(A \cup B) = P(A) + P(B)$

Odds in Favour and Against

Odds in favour of $A = A : \bar{A}$

Odds against of $A = \bar{A} : A$

$$P(A) = \frac{A}{A + \bar{A}} \text{ and } P(\bar{A}) = \frac{\bar{A}}{A + \bar{A}}$$

e.g. Odds in favour of A solving a problem
is 3:5

$$P(A) = \frac{3}{8} \text{ and } P(\bar{A}) = \frac{5}{8}$$

e.g. Odds against A solving a problem
is 4:5

$$P(A) = \frac{5}{9} \text{ and } P(\bar{A}) = \frac{4}{9}$$

Set Theory in Probability

- $P(A \text{ or } B) = P(A \cup B) = P(\text{Atleast one set})$
 $= P(A) + P(B) - P(A \cap B)$

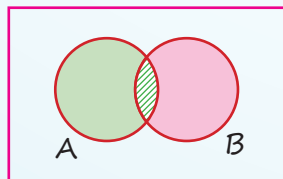

- $P(A \& B) = P(A \cap B)$
 $= P(A) + P(B) - P(A \cup B)$

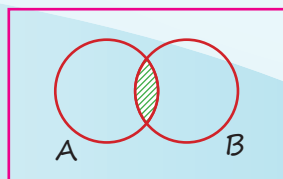

- $P(A \text{ but not } B)$
 $= P(\text{only } A)$
 $= P(A - B)$
 $= P(A \cap \bar{B})$
 $= P(A) - P(A \cap B)$

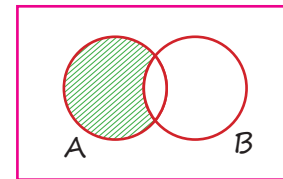

- $P(B \text{ but not } A)$
 $= P(\text{only } B)$
 $= P(B - A)$
 $= P(B \cap \bar{A})$
 $= P(B) - P(A \cap B)$

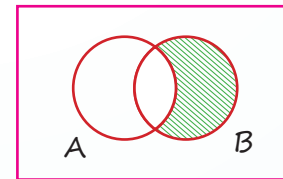

- $P(\text{Neither } A \text{ nor } B)$
 $= P(A' \cap B') = P(A \cup B)'$
 $= 1 - P(A \cup B)$

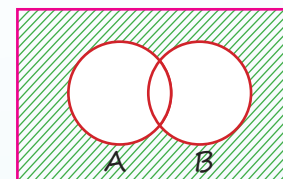

- $P(\text{not } A \text{ or not } B)$
 $= P(A' \cup B') = P(A \cap B)'$
 $= 1 - P(A \cap B)$

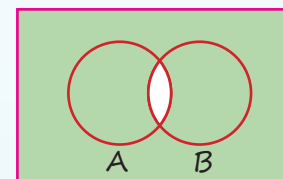

Conditional Probability

$P\left(\frac{A}{B}\right) = \text{Prob. of event of } A \text{ when event } B \text{ has already occurred.}$

$$P\left(\frac{A}{B}\right) = \frac{P(A \cap B)}{P(B)} \quad \text{where } P(B) \neq 0$$

$$\square P\left(\frac{A}{\bar{B}}\right) = \frac{P(A \cap \bar{B})}{P(\bar{B})}, P(\bar{B}) \neq 0$$

$$\square P\left(\frac{\bar{A}}{\bar{B}}\right) = \frac{P(\bar{A} \cap \bar{B})}{P(\bar{B})}, P(\bar{B}) \neq 0$$

Compound Probability Theorem

$$P(A \cap B) = P(A) \times P\left(\frac{B}{A}\right)$$

$$P(A \cap B \cap C) = P(A) \times P\left(\frac{B}{A}\right) \times P\left(\frac{C}{A \cap B}\right)$$

For Independent Events

A and B are independent

if $P(A \cap B) = P(A) \times P(B)$

or

$$P\left(\frac{A}{B}\right) = P(A) \text{ and } P\left(\frac{B}{A}\right) = P(B)$$

Total Probability Theorem

A and B are independent

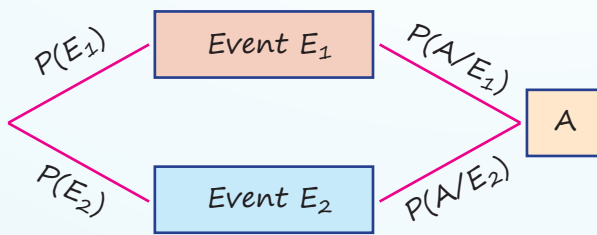

$$P(A) = P(E_1) P\left(\frac{A}{E_1}\right) + P(E_2) P\left(\frac{A}{E_2}\right)$$

Random Variable and Probability Distribution

Random variable (x_i): Variable on the basis of which probability is distributed.

e.g. No. of Heads, Age, Weight

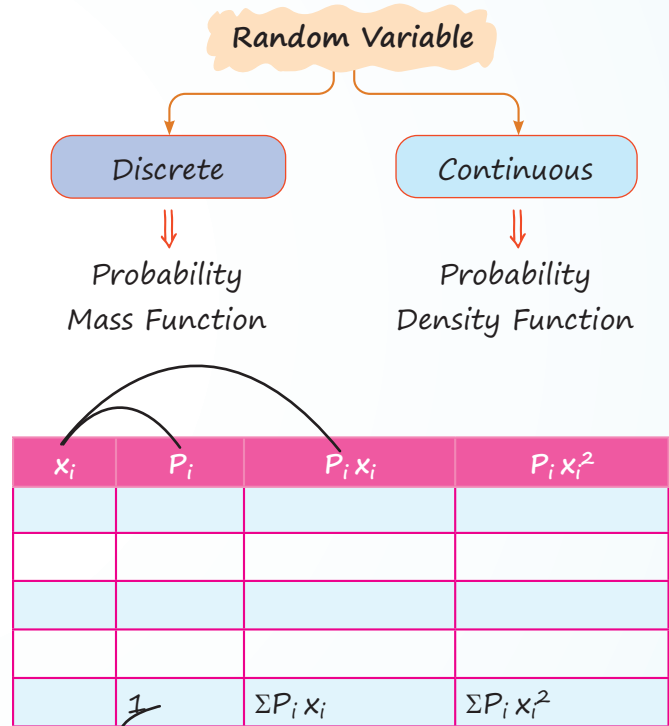

$\Sigma P_i = 1$
(always)

Mean (μ) = $E(x) = \Sigma P_i x_i$
(expectation)

- Variance = $\sigma^2 = \Sigma P_i (x_i - \mu_i)^2$
or
 $\Sigma P_i x_i^2 - (\Sigma P_i x_i)^2$
or
 $E(x^2) - [E(x)]^2$

- S.D. = $\sqrt{\text{Variance}}$
- For a constant k
 $E(k) = k$
- $E(x + y) = E(x) + E(y)$
- $E(kx) = kE(x)$
- If x and y are independent
 $E(x \cdot y) = E(x) \cdot E(y)$

QUESTIONS

Classical Definition of Probability

1. A class consists of 10 boys and 20 girls of which half of boys and half the girls have blue eyes. Find the probability that a student chosen at random is a boy and has blue eyes. [MTP-May, 2025]

(a) $\frac{1}{6}$	(b) $\frac{3}{5}$
(c) $\frac{1}{2}$	(d) None of these
2. In a leap year, what is the probability that there will be 53 Sundays? [PYQ-May, 2025]

(a) $\frac{53}{365}$	(b) $\frac{1}{7}$
(c) $\frac{3}{7}$	(d) $\frac{2}{7}$
3. In a non-leap year, the probability of getting 53 Sundays or 53 Tuesdays or 53 Thursdays is: [MTP-Jan. 2025]

(a) $\frac{4}{7}$	(b) $\frac{2}{7}$
(c) $\frac{3}{7}$	(d) $\frac{1}{7}$
4. What is the chance of picking a heart or a queen not of heart from a pack of 52 cards? [MTP-May, 2025]

(a) $\frac{17}{52}$	(b) $\frac{1}{13}$
(c) $\frac{4}{13}$	(d) $\frac{3}{13}$
5. What is the chance of picking a spade or an ace not of spade from a pack of 52 cards? [MTP-Jan. 2025]

(a) $\frac{4}{13}$	(b) $\frac{2}{13}$
(c) $\frac{3}{26}$	(d) $\frac{3}{18}$
6. Three identical dice are rolled. The probability that the same number will appear on each of them is: [MTP-Jan, 2025]

(a) $\frac{1}{6}$	(b) $\frac{1}{12}$
(c) $\frac{1}{36}$	(d) 1

7. If x be the sum of two numbers obtained when two die are thrown simultaneously then $P(x \geq 7)$ is [MTP-May, 2025]

(a) $\frac{5}{12}$	(b) $\frac{7}{12}$	(c) $\frac{11}{15}$	(d) $\frac{3}{8}$
--------------------	--------------------	---------------------	-------------------
8. Find the probability that a four-digit number comprising the digits 2, 5, 6 and 7 would be divisible by 4. [MTP-Jan. 2025]

(a) $\frac{1}{4}$	(b) $\frac{1}{3}$
(c) $\frac{1}{2}$	(d) 1

Relative Frequency Definition of Probability

9. Eight labourers are working at a each day of working (in 2): following wages for each day of working (in ₹):
500, 620, 400, 700, 450, 560, 320, 450
If one of the workers is selected then what is the probability that his wage would be less than the average wage? [PYQ-Sep. 2024]

(a) 0.375	(b) 0.625
(c) 0.500	(d) 0.450
10. A box contains shoe pairs of same pattern of different sizes numbered from 1 to 12. If a shoe pair is selected at random, what is the probability that the number on the shoe pair will be a multiple of 5 or 6? [PYQ-Sep. 2024]

(a) 0.25	(b) 0.20
(c) 0.33	(d) 0.375
11. A number is selected from the first 20 natural numbers. Find the probability that it would be divisible by 3 or 7. [PYQ-May, 2025]

(a) $\frac{7}{20}$	(b) $\frac{12}{37}$
(c) $\frac{24}{67}$	(d) $\frac{8}{20}$
12. Two dice are thrown simultaneously. Find the probability that the sum of digits on the two dice would be 8 or more. [PYQ-May, 2025]

(a) $\frac{5}{18}$	(b) $\frac{5}{12}$
(c) $\frac{5}{36}$	(d) $\frac{7}{12}$

Operations on Events

13. Which of the following pairs of events are mutually exclusive? [PYQ-Sep. 2024]

- (a) A: Archana was born in India. B: She is a fine lawyer.
 (b) A: The student studies in a school. B: He studies Geography.
 (c) A: Sita is 16 years old. B: She is a good folk dancer.
 (d) A: Imran is under 15 years of age. B: He is a voter of Delhi.

14. Three events A, B and C are mutually exclusive, exhaustive and equally likely.

What is the probability of the complementary event of A? [MTP-Jan. 2025]

- (a) $\frac{1}{3}$ (b) $\frac{2}{3}$
 (c) $\frac{3}{7}$ (d) 1

15. A card is drawn from a well shuffled pack of 52 cards. Let E_1 , "a king or a queen is drawn" and E_2 : "a queen or a jack is drawn", then:

[MTP-Jan. 2025]

- (a) E_1 and E_2 are not independent
 (b) E_1 and E_2 are mutually exclusive
 (c) E_1 and E_2 are independent
 (d) None of these

16. If $P(A) = 0.65$ and $P(B) = 0.15$, then $P(\bar{A}) + P(\bar{B})$ is [PYQ-Sep. 2024]

- (a) 1.2 (b) 0.8
 (c) 1.5 (d) 0.35

17. Which one holds correct for any two events A and B [PYQ-Sep. 2024]

- (a) $P(A - B) = P(A) - P(A \cap B)$
 (b) $P(A - B) = P(A) - P(B)$
 (c) $P(A - B) = P(B) - P(A \cap B)$
 (d) $P(A - B) = P(B) + P(A \cap B)$

18. Let A and B be two possible outcomes of a random experiment and $P(A) = \frac{1}{3}$, $P(A \cup B) = \frac{1}{2}$ and $P(B) = x$. For what value of x are A and B mutually exclusive events? [PYQ-Jan. 2025]

- (a) $\frac{1}{6}$ (b) $\frac{1}{4}$

- (c) $\frac{1}{5}$ (d) $\frac{1}{8}$

19. Let $P(A) = \frac{1}{5}$ and $P(\bar{B}) = \frac{3}{5}$. If A and B are mutually exclusive events then $P(A \cup B)$ is

[PYQ-Jan. 2025]

- (a) $\frac{3}{5}$ (b) $\frac{1}{5}$
 (c) $\frac{2}{5}$ (d) $\frac{4}{5}$

20. The probability that a card drawn at random from the pack of playing cards may be either a queen or ace is [MTP-May, 2025]

- (a) $\frac{2}{13}$ (b) $\frac{11}{13}$
 (c) $\frac{9}{13}$ (d) None

21. If the probability of a horse A winning a race is $\frac{1}{6}$ and probability of a horse B winning the same race is $\frac{1}{4}$, _____ is the probability that one of the horses will win. [MTP-May, 2025]

- (a) $\frac{1}{3}$ (b) $\frac{7}{12}$
 (c) $\frac{1}{12}$ (d) $\frac{1}{7}$

22. The probability that an Accountant's job applicant has a B.Com. Degree is 0.85, that he is a CA is 0.30 and that he is both B.Com. and CA is 0.25. Out of 500 applicants, how many would be B.Com. or CA? [MTP-Jan. 2025]

- (a) 0.25 (b) 0.30
 (c) 0.10 (d) 0.90

Axiomatic or Modern Definition of Probability

23. A company produces two types of products. A and B. The probability of a defective product in type A is 0.05 and in type B is 0.03. If the company produces 60% type A and 10% type B. what is the probability of a randomly selected product being defective? [PYQ-Jun. 2023]

- (a) 0.042
 (b) 0.03
 (c) 0.048
 (d) 0.052

24. In a class, there are 15 boys and 10 girls. Three students are selected at random. The probability that 1 girl and 2 boys are selected is:

[PYQ-May, 2025]

- (a) $\frac{21}{46}$ (b) $\frac{25}{17}$
 (c) $\frac{1}{50}$ (d) $\frac{3}{25}$

25. A question in statistics is given to three students A, B, and C. Their chances of solving the question are $\frac{1}{3}$, $\frac{1}{5}$ and $\frac{1}{7}$ respectively. The probability that the question would be solved is

[PYQ-Jun, 2024]

- (a) $\frac{19}{35}$ (b) $\frac{16}{35}$
 (c) $\frac{1}{105}$ (d) $\frac{104}{105}$

26. Rupesh is known to hit a target in 5 out of 9 shots whereas David is known to hit the same target in 6 out of 11 shots. What is the probability that the target would be hit once they both try?

[MTP-Jan, 2025]

- (a) $\frac{79}{99}$ (b) $\frac{10}{13}$
 (c) $\frac{14}{26}$ (d) $\frac{13}{18}$

27. A number is selected at random from the set $\{1, 2, \dots, 99\}$. The probability that it is divisible by 9 or 11 is

[PYQ-Jun, 2024]

- (a) $\frac{19}{100}$ (b) $\frac{19}{99}$
 (c) $\frac{10}{100}$ (d) $\frac{10}{99}$

Conditional Probability and Compound Theorem of Probability

28. The theory of the compound probability states that for any two events A and B:

(MTP-May 2025, MTP-Jan 2025)

- (a) $P(A \cap B) = P(A) \times P(B)$
 (b) $P(A \cap B) = P(A) \times P(B/A)$
 (c) $P(A \cup B) = P(A) \times P(B)$
 (d) $P(A \cup B) = P(A) + P(B) - P(A \cap B)$

29. In connection with a random experiment, it is found that $P(A) = \frac{2}{3}$, $P(B) = \frac{3}{5}$ and $P(A \cup B) = \frac{5}{6}$, find $P(A/B)$

[MTP-Jan, 2025]

- (a) $\frac{7}{18}$ (b) $\frac{1}{13}$
 (c) $\frac{5}{18}$ (d) $\frac{13}{18}$

30. Two cards are drawn at random from a pack of 52 cards. The probability of getting either both the red cards or both Kings cards is

[PYQ-Sep, 2024]

- (a) 0.4288 (b) 0.2488
 (c) 0.8248 (d) 0.8428

31. The probability that a trainee will remain with a company is 0.8. The probability that an employee earns more than ₹20,000 per month is 0.4. The probability that an employee, who was a trainee and remained with the company or who earns more than ₹20,000 per month is 0.9. What is the probability that an employee earns more than ₹20,000 per month given that he is a trainee, who stayed with the company?

[MTP-May, 2025]

- (a) $\frac{5}{8}$ (b) $\frac{3}{8}$
 (c) $\frac{1}{8}$ (d) $\frac{7}{8}$

32. Two cards are drawn from a pack of 52 cards. The probability that one is a spade and one is a heart is:

[PYQ-May, 2025]

- (a) $\frac{3}{20}$ (b) $\frac{29}{34}$
 (c) $\frac{47}{100}$ (d) $\frac{13}{102}$

33. From a bag containing 4 red, 5 blue and 6 white caps, two caps are drawn without replacement. What is the probability that the caps are of different colours?

[PYQ-June, 2023]

- (a) $\frac{74}{105}$ (b) $\frac{37}{105}$
 (c) $\frac{94}{105}$ (d) $\frac{31}{105}$

34. Company A produces 10% defective products, company B produces 20% defective products and company C produces 5% defective products. If choosing a company is an equally likely event, what is the probability that product chosen is free from defect?

[PYQ-Jun, 2023]

- (a) 0.88 (b) 0.80
 (c) 0.79 (d) 0.78

35. A problem is given to 5 students P, Q, R, S and T. If the probability of solving the problem individually is $\frac{1}{2}$, $\frac{1}{3}$, $\frac{2}{3}$, $\frac{1}{5}$ and $\frac{1}{6}$ respectively, then find the probability that the problem is solved. [PYQ-May, 2025]

- (a) 0.47 (b) 0.93
(c) 0.57 (d) 0.27

36. The odds are 9:5 against a person who is 50 years living till he is 70 and 8:6 against a person who is 60 living till he is 80. Find the probability that at least one of them will be alive after 20 years. [MTP-May, 2025]

- (a) $\frac{11}{14}$ (b) $\frac{22}{49}$
(c) $\frac{31}{49}$ (d) $\frac{35}{49}$

37. The probability of success of three students in CA Foundation examination are $\frac{1}{5}$, $\frac{1}{4}$ and $\frac{1}{3}$ respectively. Find the probability that at least two students will get success. [PYQ-Sep, 2024]

- (a) $\frac{3}{4}$ (b) $\frac{2}{5}$
(c) $\frac{1}{6}$ (d) $\frac{1}{5}$

38. A father had three sons namely, Kailash, Harish and Prakash. All are above 65 years in age. Prakash happens to be the eldest while Kailash as youngest. As per the health history, it is estimated that the probability that Kailash survives another 5 years is $\frac{4}{5}$, Harish survives another 5 years is $\frac{3}{5}$ and Prakash survives another 5 years is $\frac{1}{2}$. The probabilities that Kailash and Harish survive another 5 years is 0.46, Harish and Prakash survive another 5 years is 0.32 and Kailash and Prakash survive another 5 years is 0.48.

The probability that all three sons survive another 5 years is 0.26. What shall be the probability that at least one of them survives another 5 years?

[PYQ-May, 2025]

- (a) 0.78 (b) 0.72
(c) $\frac{7}{10}$ (d) $\frac{9}{10}$

39. A random variable has the following probability distribution: [PYQ-June, 2023]

X	P
2	K
3	2K
5	2K

Find K.

- (a) $\frac{1}{3}$ (b) $\frac{2}{5}$
(c) $\frac{1}{5}$ (d) $\frac{2}{3}$

40. A random variable X has the following probability density function; $f(x) = 6x(1 - x)$, $0 \leq x \leq 1$, then the mean is [PYQ-Jan, 2025]

- (a) $\frac{1}{3}$ (b) $\frac{1}{12}$
(c) $\frac{1}{4}$ (d) $\frac{1}{2}$

41. In a business venture, a man can make a profit of ₹50,000 or incur a loss of ₹20,000. The probabilities of making profit or incurring loss, from the past experience, are known to be 0.75 and 0.25 respectively. What is his expected profit? [MTP-Jan, 2025]

- (a) ₹33,500 (b) ₹34,500
(c) ₹35,500 (d) ₹32,500

ANSWER KEY

1. (a) 2. (d) 3. (c) 4. (c) 5. (a) 6. (c) 7. (b) 8. (b) 9. (c) 10. (a)
11. (d) 12. (b) 13. (d) 14. (b) 15. (a) 16. (a) 17. (b) 18. (a) 19. (a) 20. (a)
21. (a) 22. (d) 23. (a) 24. (a) 25. (a) 26. (a) 27. (b) 28. (b) 29. (d) 30. (a)
31. (b) 32. (d) 33. (a) 34. (a) 35. (b) 36. (c) 37. (c) 38. (d) 39. (c) 40. (d)
41. (d)

HINTS & SOLUTIONS

1. (a) Given,

Number of boys = 10

Number of girls = 20

Number of boys with blue eyes = 5

Number of girls with blue eyes = 10

Thus, the probability that a student chosen at random is a boy and has blue eyes = $\frac{5}{30} = \frac{1}{6}$

Therefore, the required probability is $\frac{1}{6}$.

Hence, the correct option is (A).

2. (d) We know,

In a leap year, there are 52 weeks and 2 extra days

2 remaining days can be: {Sun-Mon, Mon-Tue, Tues-Wed, Wed-Thurs, Thurs-Fri, Fri-Sat, Sat-Sun}. Thus, for a leap year having 53 Sunday, 2 extra days should be {Sat-Sun} or {Sun-Mon}.

Therefore, the required probability = $\frac{2}{7}$.

3. (a) According to the question,

In a leap year there are complete 52 weeks and 1 extra day.

That day can be Sunday or Tuesday or Thursday.

Sample Space is: $S = \{\text{Sunday, Monday, Tuesday, Wednesday, Thursday, Friday, Saturday}\}$

Total Number of Outcomes, $n(S) = 7$

Let E be an event of getting an extra day as Sunday, Tuesday and Thursday.

$n(E) = 3$

So, the Probability = $\frac{3}{7}$.

4. (c) We know,

Number of hearts in a pack of 52 cards = 13

Number of queens but not of heart = 3

Therefore, the chance of picking a heart or a queen not of heart from a pack of 52 cards is given by;

$$\frac{13}{52} + \frac{3}{52} = \frac{16}{52} = \frac{4}{13}$$

5. (a) **Event 1:** Picking a spade = 13 cards

Event 2: Picking an ace not of spade = 3 cards (aces of hearts, diamonds, clubs)

Favourable outcome = $13 + 3 = 16$

Total cards = 52

$$P = \frac{16}{52} = \frac{4}{13}$$

6. (c) Total Number of Outcomes when 3 dices are rolled = $n(S) = 6^3 = 216$

Favourable Outcomes will be given as,

Let there be an event E denoting the appearance of the same number on all the dices.

$E = \{(1, 1, 1), (2, 2, 2), (3, 3, 3), (4, 4, 4), (5, 5, 5), (6, 6, 6)\}$

$\Rightarrow n(E) = 6$

$$\text{Probability} = \frac{n(E)}{n(S)} = \frac{6}{216} = \frac{1}{36}$$

7. (b) Given;

Total outcomes = 36

Therefore, favorable outcomes

Sum	Combinations
7	(1, 6), (2, 5), (3, 4), (4, 3), (5, 2), (6, 1) → 6
8	(2, 6), (3, 5), (4, 4), (5, 3), (6, 2) → 5
9	(3, 6), (4, 5), (5, 4), (6, 3) → 4
10	(4, 6), (5, 5), (6, 4) → 3
11	(5, 6), (6, 5) → 2
12	(6, 6) → 1

Favourable outcome = $6 + 5 + 4 + 3 + 2 + 1 = 21$

$$\text{Hence, } P(x \geq 7) = \frac{21}{36} = \frac{7}{12}$$

8. (b) Given;

Digits: 2, 5, 6, 7

Total 4-digit numbers = $4! = 24$

Here, Last two digits divisible by 4: 52, 56, 72, 76 (4 pairs)

For each pair, first two digits can be arranged in $2! = 2$ ways.

Total valid numbers = $4 \times 2 = 8$

$$\text{Probability} = \frac{8}{24} = \frac{1}{3}$$

9. (c) Given wages (in ₹) :

500, 620, 400, 700, 450, 560, 320, 450

Average

$$= \frac{500+620+400+700+450+560+320+450}{8}$$

$$= \frac{4000}{8} = 500$$

Now, wages less than 500 are :

- 400
- 450
- 320
- 450

Count = 4

Therefore, the required probability is

$$P(\text{wage} < 500) = \frac{4}{8} = 0.5$$

10. (a) Given:

- Shoe pairs numbered from 1 to 12
- Total number of pairs = 12

Here,

Number of multiples of 5 = 2(5, 10)

Number of multiples of 6 = 2(6, 12)

Number of multiples of both = 0

Therefore, the required probability,

$$P = \frac{4}{12} = \frac{1}{3} = 0.33 \text{ (approx.)}$$

11. (d) We know,

First 20 natural numbers: 1 to 20

Numbers divisible by 3: 3, 6, 9, 12, 15, 18 → 6 numbers

Numbers divisible by 7: 7, 14 → 2 numbers

No number from 1 to 20 is divisible by both 3 and 7.

So, total favorable numbers = 6 + 2 = 8

$$\text{Hence, Probability} = \frac{8}{20}.$$

12. (b) Here, list of outcomes where sum ≥ 8 .

Sum	Combinations	Count
8	(2, 6), (3, 5), (4, 4), (5, 3), (6, 2)	5
9	(3, 6), (4, 5), (5, 4), (6, 3)	4
10	(4, 6), (5, 5), (6, 4)	3
11	(5, 6), (6, 5)	2
12	(6, 6)	1

Total favorable outcomes = 5 + 4 + 3 + 2 + 1 = 15

$$\text{Hence, } P(\text{sum} \geq 8) = \frac{15}{36} = \frac{5}{12}.$$

13. (d) Option (a):

These two events can happen together (some-one born in India can be a fine lawyer).

Not mutually exclusive

Option (b):

A student studying in a school can also study Geography.

Not mutually exclusive

Option (c):

Age and skill are unrelated, both can happen simultaneously.

Not mutually exclusive

Option (d):

To be a voter, one must be at least 18 years old.

So, Imran cannot be under 15 and a voter simultaneously.

Mutually exclusive events.

14. (b)

Since A, B and C are mutually exclusive, exhaustive, and equally likely:

$$P(A) = P(B) = P(C) = \frac{1}{3}$$

The complementary event of A is A^c , which includes B and C:

$$P(A^c) = 1 - P(A) = 1 - \frac{1}{3} = \frac{2}{3}.$$

15. (a) Given:

- E_1 : King or Queen → 8 cards
- E_2 : Queen or Jack → 8 cards
- $E_1 \cap E_2$: Queen → 4 cards

For independence:

$$P(E_1 \cap E_2) = \frac{4}{52}, \quad P(E_1) \cdot P(E_2) = \frac{8}{52} \cdot \frac{8}{52} \neq \frac{4}{52}$$

So, they are not independent.

16. (a) We are given:

- $P(A) = 0.65 \Rightarrow P(A') = 1 - 0.65 = 0.35$
- $P(B) = 0.15 \Rightarrow P(B') = 1 - 0.15 = 0.85$

Therefore,

$$P(A') + P(B') = 0.35 + 0.85 = 1.2$$

17. (b) We know,

$A - B$ means the event that A happens but B does not.

$$\text{So, } P(A - B) = P(A \cap B^c)$$

where, B^c is the complement of B .

$$\text{Therefore, } P(A - B) = P(A) - P(A \cap B)$$

18. (a) Given; $P(A) = \frac{1}{3}$, $P(A \cup B) = \frac{1}{2}$ and $P(B) = x$

Since, A and B are mutually exclusive events which is given by:

$$P(A \cup B) = P(A) + P(B)$$

$$\Rightarrow \frac{1}{2} = \frac{1}{3} + x$$

$$\Rightarrow x = \frac{1}{2} - \frac{1}{3}$$

$$\Rightarrow x = \frac{1}{6}$$

Therefore, the value of x is $\frac{1}{6}$.

19. (a) Given; $P(A) = \frac{1}{5}$ and $P(\bar{B}) = \frac{3}{5}$.

Since, A and B are mutually events, then

$$P(A \cap B) = 0$$

$$\Rightarrow P(B) = 1 - \frac{3}{5} = \frac{2}{5}$$

$$\text{Thus, } P(A \cup B) = P(A) + P(B)$$

$$\Rightarrow P(A \cup B) = \frac{1}{5} + \frac{2}{5}$$

$$\Rightarrow P(A \cup B) = \frac{3}{5}$$

20. (a) We know that,

Total cards = 52

Number of queens = 4

Number of aces = 4

Let A and B be the events that the card is queen or ace respectively, then

$$P(A) = \frac{4}{52} = \frac{1}{13} \text{ and } P(B) = \frac{4}{52} = \frac{1}{13}$$

Thus, the probability that a card drawn is either a queen or an ace = $P(A \cup B)$

$$= P(A) + P(B)$$

(since, the events are mutually exclusive)

$$= \frac{1}{13} + \frac{1}{13} = \frac{2}{13}$$

Hence, the correct option is (a).

21. (a) Let,

$P(A)$: Horse A winning

$P(B)$: Horse B winning

$$\text{i.e., } P(A) = \frac{1}{6} \text{ and } P(B) = \frac{1}{4}$$

$$\Rightarrow P(A') = 1 - P(A) = 1 - \frac{1}{6} = \frac{5}{6}$$

$$\Rightarrow P(B') = 1 - P(B) = 1 - \frac{1}{4} = \frac{3}{4}$$

Now, the probability that one of the horses will win will be given by:

$$= P(A \text{ wins and } B \text{ lose}) + P(A \text{ lose and } B \text{ wins})$$

$$= P(A \cap B') + P(A' \cap B)$$

$$= P(A) \cdot P(B') + P(A') \cdot P(B)$$

$$= \frac{1}{6} \times \frac{3}{4} + \frac{5}{6} \times \frac{1}{4} = \frac{3+5}{24} = \frac{8}{24} = \frac{1}{3}$$

22. (d) Given:

- $P(\text{B.Com}) = 0.85$

- $P(\text{CA}) = 0.30$

- $P(\text{B.Com} \cap \text{CA}) = 0.25$

- Total applicants = 500

Therefore,

$$P(\text{B.Com} \cup \text{CA}) = P(\text{B.Com}) + P(\text{CA}) - P(\text{B.Com} \cap \text{CA}) = 0.85 + 0.30 - 0.25 = 0.90$$

23. (a) Given;

$$P(\text{Defective}|A) = 0.05$$

$$P(\text{Defective}|B) = 0.03$$

Therefore,

$$P(\text{Defective}) = P(A) \cdot P(D|A) + P(B) \cdot P(D|B)$$

$$= (0.6 \times 0.05) + (0.4 \times 0.03)$$

$$= 0.03 + 0.012$$

$$= 0.042$$

24. (a) Given;

Number of boys = 15 and Number of girls = 10

Therefore, the probability that 1 girl and 2 boys are selected is given by

$$= \frac{{}^{10}C_1 \times {}^{15}C_2}{{}^{25}C_3}$$

$$= \frac{10 \times 15 \times 14}{25 \times 24 \times 23} = \frac{21}{46}$$

25. (a) Given;

$$P(A) = \frac{1}{3}; P(B) = \frac{1}{5}; P(C) = \frac{1}{7}$$

We know,

$$P(\text{at least one solves}) = 1 - P(\text{none solve})$$

Now,

$$P(\text{none solve}) = (1 - P(A)) \cdot (1 - P(B)) \cdot (1 - P(C))$$

$$= \left(1 - \frac{1}{3}\right) \cdot \left(1 - \frac{1}{5}\right) \cdot \left(1 - \frac{1}{7}\right) = \frac{2}{3} \cdot \frac{4}{5} \cdot \frac{6}{7}$$

$$= \frac{2 \cdot 4 \cdot 6}{3 \cdot 5 \cdot 7} = \frac{48}{105}$$

Therefore,

$$P(\text{Solved}) = 1 - \frac{48}{105} = \frac{105 - 48}{105} = \frac{57}{105} = \frac{19}{35}$$

26. (a) Given:

$$P(\text{Rupesh hits}) = \frac{5}{9}$$

$$P(\text{David hits}) = \frac{6}{11}$$

Therefore, Probability (Atleast one will hit)

$$= 1 - P(\text{None})$$

$$= 1 - \left(1 - \frac{5}{9}\right) \times \left(1 - \frac{6}{11}\right)$$

$$= 1 - \frac{4}{9} \times \frac{5}{11}$$

$$= 1 - \frac{20}{99} = \frac{79}{99}$$

27. (b) Given;

Total numbers = 99

$$1. \text{ Divisible by } 9 : \left\lfloor \frac{99}{9} \right\rfloor = 11 \text{ numbers}$$

$$2. \text{ Divisible by } 11 : \left\lfloor \frac{99}{11} \right\rfloor = 9 \text{ numbers}$$

3. Divisible by both 9 and 11 (LCM = 99):

$$\left\lfloor \frac{99}{99} \right\rfloor = 1 \text{ number}$$

Therefore, Favorable outcomes = 11 + 9 - 1 = 19

$$\text{Hence, the required probability} = \frac{19}{99}$$

28. (b) We know that,

For any two events A and B , the compound (joint) probability is given by:

$$P(A \cap B) = P(A) \times P(B|A)$$

29. (d) We know,

$$P(A \cup B) = P(A) + P(B) - P(A \cap B)$$

$$\Rightarrow P(A \cap B) = P(A) + P(B) - P(A \cup B)$$

$$= \frac{2}{3} + \frac{3}{5} - \frac{5}{6}$$

$$= \frac{20}{30} + \frac{18}{30} - \frac{25}{30} = \frac{13}{30}$$

Therefore,

$$\frac{P(A \cap B)}{P(B)} = \frac{13/30}{3/5} = \frac{13}{30} \times \frac{5}{3} = \frac{65}{90} = \frac{13}{18}$$

30. (a) Given;

Number of red cards = 26

Number of kings = 4

Red kings = 2 (hearts and diamonds)

Therefore, the required probability

$$\frac{{}^{26}C_2 + {}^4C_2 - {}^2C_2}{{}^{52}C_2}$$

$$= \frac{26 \times 25 + 4 \times 3 - 2 \times 1}{52 \times 51} = \frac{660}{2652} = 0.4288$$

31. (b) According to question, we have

Let A : Trainee remains with company $\rightarrow P(A) = 0.8$

Let B : Employee earns more than ₹20,000 $\rightarrow P(B) = 0.4$

Given: $P(A \cup B) = 0.9$

Required: $P(B|A)$ = Probability that an employee earns > ₹20,000 given he is a trainee who stayed with the company.

We know,

$$P(A \cup B) = P(A) + P(B) - P(A \cap B)$$

$$\Rightarrow 0.9 = 0.8 + 0.4 - P(A \cap B)$$

$$\Rightarrow P(A \cap B) = 1.2 - 0.9 = 0.3$$

$$\text{Therefore, } P(B|A) = \frac{P(A \cap B)}{P(A)} = \frac{0.3}{0.8} = \frac{3}{8}$$

32. (d) According to question, we have

Number of ways to choose 2 cards from 52 cards

$$= {}^{52}C_2 = 1326$$

Also, Favorable outcomes of choosing 1 spade and 1 heart

$$= {}^{13}C_1 \times {}^{13}C_1 = 13 \times 13 = 169$$

Therefore, the required probability

$$= \frac{169}{1326} = \frac{13}{102}$$

33. (a) Given;

Red = 4, Blue = 5 and White = 6

Total = 4 + 5 + 6 = 15 caps

Therefore, the required probability

$$= \frac{{}^{15}C_1 \cdot {}^{15}C_1 + {}^5C_1 \cdot {}^6C_1 + {}^4C_1 \cdot {}^6C_1}{{}^{15}C_2}$$

$$= \frac{4 \times 5 + 5 \times 6 + 4 \times 6}{105} = \frac{74}{105}$$

34. (a) Given; Company A produces 10% defective products, company B produces 20% defective products and company C produces 5% defective products.

Thus,

$$P(\text{defective}) = \frac{1}{3} \times 0.1 + \frac{1}{3} \times 0.2 + \frac{1}{3} \times 0.05$$

$$\Rightarrow P(\text{defective}) = \frac{0.35}{3} = 0.116$$

Therefore, the probability that product chosen is free from defect is given by

$$P(\text{free from defect}) = 1 - P(\text{defective})$$

$$\Rightarrow P(\text{free from defect}) = 1 - 0.116$$

$$\Rightarrow P(\text{free from defect}) = 0.883$$

35. (b) Given;

$$P(P) = \frac{1}{2}; \quad P(Q) = \frac{1}{3}$$

$$P(R) = \frac{2}{3}; \quad P(S) = \frac{1}{5}$$

$$P(T) = \frac{1}{6}$$

Now,

$$P(\text{Problem is solved}) = 1 - P(\text{None solve})$$

$$= 1 - \left(1 - \frac{1}{2}\right) \left(1 - \frac{1}{3}\right) \left(1 - \frac{2}{3}\right) \left(1 - \frac{1}{5}\right) \left(1 - \frac{1}{6}\right)$$

$$= 1 - \frac{1}{2} \cdot \frac{2}{3} \cdot \frac{1}{3} \cdot \frac{4}{5} \cdot \frac{5}{6}$$

$$= 1 - \frac{2}{27} = \frac{25}{27} \approx 0.93$$

36. (c) Given;

Person A : Odds against = 9:5 \rightarrow

$$P(A \text{ survives}) = \frac{5}{14}, P(A \text{ dies}) = \frac{9}{14}$$

Person B : Odds against = 8:6 \rightarrow

$$P(B \text{ survives}) = \frac{3}{7}, P(B \text{ dies}) = \frac{4}{7}$$

At least one survives :

$$P = 1 - P(\text{both die})$$

$$= 1 - \left(\frac{9}{14} \cdot \frac{4}{7}\right) = 1 - \frac{36}{98} = \frac{31}{49}$$

37. (c)

$$\bullet P(A) = \frac{1}{5}$$

$$\bullet P(B) = \frac{1}{4}$$

$$\bullet P(C) = \frac{1}{3}$$

Therefore, the probabilities of failures is given by

$$P(A') = 1 - \frac{1}{5} = \frac{4}{5}$$

$$P(B') = 1 - \frac{1}{4} = \frac{3}{4}$$

$$P(C') = 1 - \frac{1}{3} = \frac{2}{3}$$

\bullet A and B succeed, C fails:

$$\frac{1}{5} \times \frac{1}{4} \times \frac{2}{3} = \frac{2}{60} = \frac{1}{30}$$

\bullet B and C succeed, A fails:

$$\frac{4}{5} \times \frac{1}{4} \times \frac{1}{3} = \frac{4}{60} = \frac{1}{15}$$

\bullet A and C succeed, B fails:

$$\frac{1}{5} \times \frac{3}{4} \times \frac{1}{3} = \frac{3}{60} = \frac{1}{20}$$

Sum for exactly 2 succeed:

$$\frac{1}{30} + \frac{1}{15} + \frac{1}{20} = \frac{2}{60} + \frac{4}{60} + \frac{3}{60} = \frac{9}{60} = \frac{3}{20}$$

Hence, Total probability that at least two succeed

$$P = \frac{3}{20} + \frac{1}{60} = \frac{9}{60} + \frac{1}{60} = \frac{10}{60} = \frac{1}{6}$$

38. (d) Let's define:

\bullet A: Kailash survives

\bullet B: Harish survives

\bullet C: Prakash survives

Given:

$$\bullet P(A) = \frac{4}{5} = 0.80$$

$$\bullet P(B) = \frac{3}{5} = 0.60$$

- $P(C) = \frac{1}{2} = 0.50$
- $P(A \cap B) = 0.46$
- $P(B \cap C) = 0.32$
- $P(A \cap C) = 0.48$
- $P(A \cap B \cap C) = 0.26$

$$\begin{aligned}
 P(\text{at least one survives}) &= P(A \cup B \cup C) \\
 &= P(A) + P(B) + P(C) - P(A \cap B) - P(B \cap C) - \\
 &\quad P(A \cap C) + P(A \cap B \cap C) \\
 &= 0.80 + 0.60 + 0.50 - 0.46 - 0.32 - 0.48 + 0.26 \\
 &= 1.90 - 1.26 + 0.26 = 0.90 \\
 &= \frac{9}{10}
 \end{aligned}$$

39. (c) Given; Sum of total probabilities = 1

i.e., $K + 2K + 2K = 5K$

$$5K = 1$$

$$K = \frac{1}{5}$$

40. (d) Given probability density function;

$$f(x) = 6x(1-x)$$

Mean is given by;

$$\text{Mean} = \int_0^1 x \cdot f(x) dx$$

$$= \int_0^1 x \cdot 6x(1-x) dx$$

$$= 6 \int_0^1 x^2(1-x) dx$$

$$= 6 \int_0^1 (x^2 - x^3) dx$$

$$= 6 \left[\frac{x^3}{3} \right]_0^1 - 6 \left[\frac{x^4}{4} \right]_0^1$$

$$= 6 \left(\frac{1}{3} \right) - 6 \left(\frac{1}{4} \right)$$

$$= 6 \left(\frac{1}{3} - \frac{1}{4} \right)$$

$$= 6 \left(\frac{1}{12} \right)$$

$$= \frac{1}{2}$$

41. (d) Expected profit = (Profit × Probability of profit) + (Loss × Probability of loss)

$$= 50,000 \times 0.75 + (-20,000) \times 0.25$$

$$= 37,500 - 5,000$$

$$= 32,500$$



Chapter Wrap-up Test

Ready to test your knowledge?

You've got 15 questions and 20 minutes - Go for it!

1. If there are 48 marbles marked with numbers 1 to 48, then the probability of selecting a marble having the number divisible by 4 is

(a) $\frac{1}{2}$ (b) $\frac{2}{3}$
 (c) $\frac{1}{3}$ (d) $\frac{1}{4}$

2. A machine is made of two parts A and B. The manufacturing process of each part is such that probability of defective in part A is 0.08 and that B is 0.05. What is the probability that the assembled part will not have any defect?

(a) 0.934 (b) 0.864
 (c) 0.85 (d) 0.874

3. If $P(\bar{A} \cup \bar{B}) = \frac{5}{6}$, $P(A) = \frac{1}{2}$ and $P(B) = \frac{2}{3}$ what is $P(A \cup B)$?

(a) 1 (b) $\frac{5}{6}$
 (c) $\frac{2}{3}$ (d) $\frac{4}{9}$

4. A bag contains 7 Blue and 5 Green balls. One ball is drawn at random. The probability of getting a Blue ball is

(a) $\frac{5}{12}$ (c) $\frac{12}{35}$
 (b) $\frac{7}{12}$ (d) 0

5. Let P be the probability function on $S = (X_1, X_2, X_3)$ if $P(X_1) = \frac{1}{4}$ and $P(X_3) = \frac{1}{3}$, then $P(X_2)$ is equal to

(a) $\frac{5}{12}$ (b) $\frac{7}{12}$
 (c) $\frac{3}{4}$ (d) None of these

6. If A speaks 75% of truth and B speaks 80% of truth. In what percentage both of them likely contradict with each other in narrating the same questions?

(a) 60% (b) 45%
 (c) 65% (d) 35%

7. Two coins are tossed simultaneously, then the probability of getting exactly one head is

(a) $\frac{3}{4}$ (b) $\frac{2}{3}$
 (c) $\frac{1}{4}$ (d) $\frac{1}{2}$

8. If in a class, 60% of the student study Mathematics and Science and 90% of the students study Science, then the probability of a student studying Mathematics given that he is already studying Science is

(a) $\frac{1}{4}$ (b) $\frac{2}{3}$
 (c) 1 (d) $\frac{1}{2}$

9. If $P(A) = \frac{1}{3}$, $P(B) = \frac{3}{4}$ and $P(A \cap B) = \frac{1}{6}$ then $P(A/B) =$

(a) $\frac{1}{6}$ (b) $\frac{2}{9}$
 (c) $\frac{1}{2}$ (d) $\frac{1}{8}$

10. The chance of getting 7 or 11 in a throw of 2 dice is

(a) $\frac{7}{9}$ (b) $\frac{5}{9}$
 (c) $\frac{2}{9}$ (d) None of these

11. When 2- dice are thrown simultaneously then the probability of getting at least one 5 is

(a) $\frac{11}{36}$ (b) $\frac{5}{36}$
 (c) $\frac{8}{15}$ (d) $\frac{1}{7}$

12. If a coin is tossed 5 times then the probability of getting Tail and Head occurs alternative is

(a) $\frac{1}{8}$

(b) $\frac{1}{16}$

(c) $\frac{1}{32}$

(d) $\frac{1}{64}$

13. Ticket numbered 1 to 20 are mixed up and then a ticket is drawn at random. What is the probability that the ticket drawn bears a number which is multiple of 3 or 7?

(a) $\frac{1}{5}$

(b) $\frac{2}{5}$

(c) $\frac{3}{5}$

(d) None of these

14. What is the probability of having at least one 'six' appear in 3 throws of a perfect die?

(a) $\frac{5}{6}$

(b) $\left(\frac{5}{6}\right)^2$

(c) $1 - \left(\frac{1}{6}\right)^3$

(d) $1 - \left(\frac{5}{6}\right)^3$

15. The probability that a cricket team winning a match at Kanpur is $\frac{2}{5}$ and losing a match at Delhi is $\frac{1}{7}$. What is the probability of the team winning at least one match?

(a) $\frac{3}{35}$

(b) $\frac{32}{35}$

(c) $\frac{18}{35}$

(d) $\frac{17}{35}$

ANSWER KEY

1. (d) 2. (d) 3. (a) 4. (c) 5. (a) 6. (d) 7. (d) 8. (b) 9. (b) 10. (c)
11. (a) 12. (b) 13. (b) 14. (d) 15. (b)



Cheat Sheet by Anurag Sir

The tabulation of different values of random variable and their corresponding probabilities.

- **Binomial Distribution:** Also known as Bernoulli Trials

According to Bernoulli, If an experiment is performed 'n' times, then n = no. of trials

- ◆ No. of trials is a finite positive integer
- ◆ Outcomes of each trials are categorized as success (P) and failure (Q)
- ◆ In each trials, probability of success and failure remain same (Trials are independent) $p + q = 1$ and $q = 1 - p$

- ◆ If x is a random variable, then $x = 0, 1, 2, 3, \dots, n$

$$x \sim B(n, p)$$

$$f(x = r) = {}^n C_r p^r q^{n-r}$$

For, $r = 0, 1, 2, 3, \dots, n$

- ◆ $P(x = 0) + P(x = 1) + \dots + P(x = n) = 1$

- Binomial Distribution is biparametric.
- Mean (μ) = np, Variance (σ^2) = npq, S.D. (σ) = np

- ◆ Maximum variance = $\frac{n}{4}$ when $p = q = \frac{1}{2}$

- Additive Property

$$\text{If } x \sim B(n_1, p)$$

$$y \sim B(n_2, p)$$

$$\text{Then } x + y \sim B(n_1 + n_2, p)$$

- Mode of Binomial Distribution depends on the value of $(n + 1)p$

- ◆ If $(n + 1)p$ is non-integer, then Mode = $[(n + 1)p]$ (greatest integer)

- ◆ If $(n + 1)p$ is integer, then there are two modes

- ◆ First mode = $(n + 1)p$
- ◆ Second mode = $(n + 1)p - 1$

- This is used when 'n' is small and p is not small.

- **Poisson Distribution:**

- ◆ Used when probability of success in a small time interval is very small.

→ n is big and p is small

- ◆ Poisson Distribution is uni-parametric. (m is the only parameter)

- ◆ For Random variable x;

$$x \sim P(m)$$

- ◆ $P(x = r) = \frac{e^{-m} m^r}{r!}$

For $r = 0, 1, 2, 3, \dots, \infty$

- ◆ $P(x = 0) + P(x = 1) + P(x = 2) + \dots = 1$

- Mean = $m = np$, Variance = $m = np$,

$$\text{S.D} = \sqrt{m}$$

- Mode = $\begin{cases} [m] (\text{integral part}) & \text{if } m \text{ is non-integer} \\ m \text{ and } m-1 & \text{if } m \text{ is integer} \end{cases}$

- Additive Property

$$\text{If } x \sim P(m_1)$$

$$y \sim P(m_2)$$

$$\text{Then } x + y \sim P(m_1 + m_2)$$

- **Normal Distribution:**

- ◆ Also known as Gaussian Distribution

- ◆ Most important and universally accepted continuous probability Distribution function.

- ◆ It is a bi-parametric Distribution where means (μ) and variance (σ^2) are two parameters which decides the shape of normal distribution curve.

μ → It will tell central value, σ^2 → It decides the spread

- Normal curve is a symmetrical curve, skewness = zero

- Area under this curve is taken 1.

$$\int_{-\infty}^{\infty} f(x) = 1$$

$$\int_{-\infty}^{\mu} f(x) = 0.5$$

$$\int_{\mu}^{\infty} f(x) = 0.5$$

- Both tails of the curve never touches horizontal axis (x-axis).
- In Normal Distribution, Mean = Median = Mode
- Mean Deviation = 0.8σ
- Quartile deviation (QD) = 0.675σ
 $Q_1 = \mu - 0.675\sigma$
 $Q_3 = \mu + 0.675\sigma$
- Mean = Median = Mode = $\frac{Q_3 + Q_1}{2}$
- Point of Inflexion: $\mu - \sigma$ and $\mu + \sigma$

- Additive Property:**

If $x \sim N(\mu_1, \sigma_1^2)$ and $y \sim N(\mu_2, \sigma_2^2)$
then $x + y \sim N(\mu_1 + \mu_2, \sigma_1^2 + \sigma_2^2)$

- Standard Normal Variate:**

If $\mu = 0$ and $\sigma = 1$

$$f(x) = \frac{1}{\sigma\sqrt{2\pi}} e^{-\frac{1}{2}\left(\frac{x-\mu}{\sigma}\right)^2}$$

then $f(x) = \frac{1}{\sqrt{2\pi}} e^{-\frac{1}{2}x^2}$

This is known as standard normal variate;

$$z = \frac{x - \mu}{\sigma}$$

- For Standard Normal variate; $\mu = 0$ & $\sigma = 1$
 - Mean = Median = Mode = 0
 - MD = $0.8\sigma = 0.8$
 - QD = $0.675\sigma = 0.675$
 - $Q_1 = -0.675$ and $Q_3 = 0.675$
 - Point of Inflexion = -1 and 1

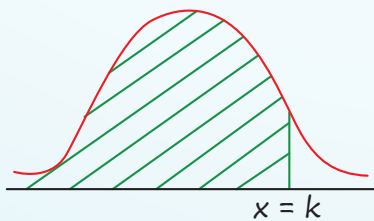
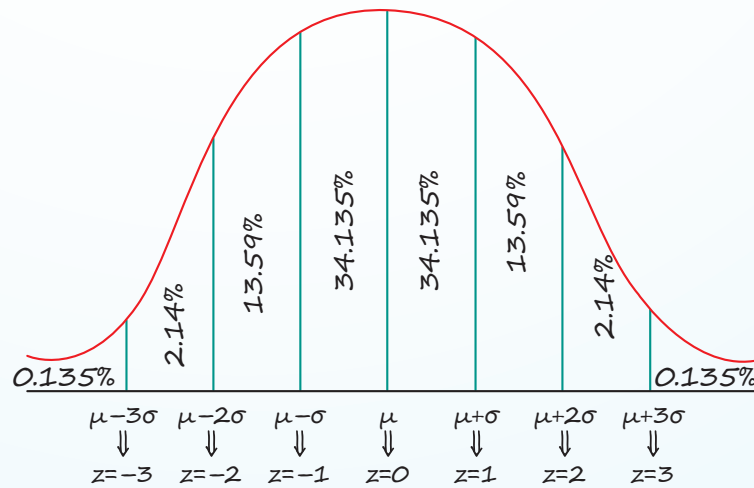

$$P(x < k) = \phi(k)$$

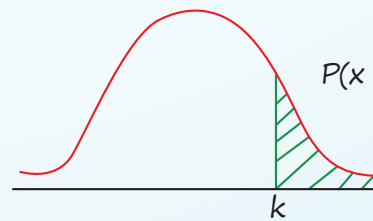

$$P(x > k) = 1 - P(x < k) = 1 - \phi(k)$$

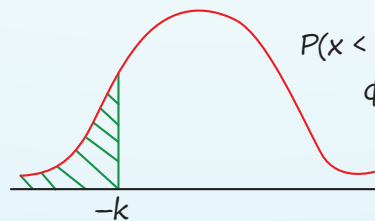

$$P(x < -k) = 1 - P(x < k) = \phi(-k) = 1 - \phi(k)$$

QUESTIONS

Binomial Distribution

1. When $p = 0.5$, the distribution is
[MTP-June 2024]
 (a) Asymmetrical (b) Symmetrical
 (c) Both of above (d) None of above

2. If mean and standard deviation of a binomial distribution is 10 and 2 respectively, q will be ___
[MTP-June 2024]
 (a) 1 (b) 0.8
 (c) 0.6 (d) 0.4

3. Find the variance of binomial distribution with $n = 10, p = 0.3$
[MTP-June, 2024]
 (a) 2.1 (b) 3
 (c) 7 (d) None of these

4. What is the probability of making 3 corrected guesses in 5 True-False answer type questions
[PYQ-May, 2025]
 (a) 0.3125 (b) 0.4156
 (c) 1.3888 (d) 0.5235

5. What will be the mode of the Binomial Distribution in which mean is 20 and standard deviation is $\sqrt{10}$?
[PYQ-Jan., 2025]
 (a) 21 (b) 20.5
 (c) 20 (d) 41

6. A biased coin is such that the probability of getting a head is thrice the probability of getting a tail. If the coin is tossed 4 times, what is the probability of getting a head all the time?
[PYQ-Jan., 2021]
 (a) $\frac{2}{5}$ (b) $\frac{81}{218}$
 (c) $\frac{81}{256}$ (d) $\frac{81}{64}$

7. For a binomial distribution, the variance is 0.2 and the mean is 0.6. The probability of getting 3 successes out of a trial of 5 is:
[PYQ-June, 2024]
 (a) $\frac{80}{3^5}$ (b) $\frac{20}{3^5}$
 (c) $\frac{40}{3^5}$ (d) $\frac{160}{3^5}$

8. The overall percentage of failure in a certain examination is 0.30. What is the probability that out of a group of 6 candidates at least 4 passed the examination?
[MTP-June, 2024]
 (a) 0.74 (b) 0.71
 (c) 0.59 (d) 0.67

9. For binomial distribution $E(x) = 2, V(x) = \frac{4}{3}$. Find the value of n .
[MTP-May, 2025]
 (a) 3 (b) 4
 (c) 5 (d) 6

10. Examine the validity of the following : Mean and standard deviation of a binomial distribution are 10 and 4 respective:
[MTP-Sept 2025]
 (a) Not valid
 (b) Valid
 (c) Both (a) and (b)
 (d) Neither (a) nor (b)

11. The mean of Binomial distribution is 20 and standard deviation is 4 then :
[MTP, Jan., 2025]
 (a) $n = 100, p = \frac{1}{5}, q = \frac{4}{5}$
 (b) $n = 50, p = \frac{2}{5}, q = \frac{2}{5}$
 (c) $n = 100, p = \frac{2}{5}, q = \frac{4}{5}$
 (d) $n = 100, p = \frac{1}{5}, q = \frac{3}{5}$

12. The probability of a man hitting the target is $\frac{1}{4}$. If he fires 7 times, the probability of hitting the target at least twice is:
[MTP-Sept 2025]
 (a) $1 - \left(\frac{5}{2}\right)\left(\frac{3}{4}\right)^6$
 (b) $1 - \frac{15}{2}\left(\frac{3}{4}\right)^6$
 (c) $1 - \frac{5}{6} \times 3^5$
 (d) $1 - \left(\frac{3}{4}\right)^6$

Poisson Distribution

13. Number of misprints per page of a thick book follows; [MTP-May 2025]
 (a) Normal distribution
 (b) Poisson distribution
 (c) Binomial distribution
 (d) Standard normal distribution
14. In _____ distribution, mean = variance. [MTP-June 2024]
 (a) Normal (b) Binomial
 (c) Poisson (d) None of these
15. Shape of Normal Distribution Curve: [MTP-Jan., 2025]
 (a) Depends on its parameters
 (b) Does not depend on its parameters
 (c) Either (a) or (b)
 (d) Neither (a) nor (b)
16. Which one is not a condition of Poisson model? [MTP-June 2024]
 (a) The probability of having failures in a small time interval is constant
 (b) The probability of having success more than one in a small time interval is very small
 (c) The probability of having success in this time interval is independent of time 't' as well as earlier success
 (d) The probability of having success in a small time interval (t, t + td) is kt for a positive constant k.
17. Poisson probability distribution is appropriately applied in [PYQ-May, 2025]
 (a) The height of students in the university.
 (b) The distribution of passing of students in university examinations.
 (c) Tossing of a coin hundred times.
 (d) Number of deaths by a rare disease.
18. A company produces 5 defective items out of 300 items. The probability distribution follows a: [PYQ-June, 2024]
 (a) Binomial distribution
 (b) Normal distribution
 (c) Poisson distribution
 (d) Standard normal distribution
19. If Standard deviation of a poisson distribution is 2, then its [MTP-May 2025]
 (a) Mode is 2
 (b) Mode is 4
 (c) Mode are 3 and 4
 (d) Modes are 4 and 5
20. For a Poisson variate X , $P(x = 1) = P(x = 2)$, what is the mean of x ? [MTP-Sept., 2025]
 (a) 1 (b) $\frac{3}{2}$
 (c) 2 (d) $\frac{5}{2}$
21. If X is a Poisson variable such that $P(X = 1) = P(X = 2)$ then the variance is [Jan., 2025]
 (a) 1 (b) 2
 (c) $\sqrt{2}$ (d) 3
22. The means of Poisson distribution is 4. The probability of two successes is: [PYQ-June, 2024]
 (a) $\frac{8}{e^4}$ (b) $\frac{4}{e^4}$
 (c) $\frac{16}{e^4}$ (d) $\frac{8}{e^2}$
23. If 3 percent of ceramic cup manufactured by a company are known to be defective. What is the probability that a sample of 100 cups are taken from the production process, of that company would contain exactly one defective cup? [PYQ-Jan., 2025]
 (a) 0.03 (b) 0.15
 (c) 0.09 (d) 0.30
24. If 5% of the families in large population city do not used gas as a fuel, what will be the probability of selecting 10 families in a random sample of 100 families who do not use gas as a fuel? [Given that $e^{-5} = 0.0067$] [PYQ-May, 2025]
 (a) 0.038 (b) Zero
 (c) 0.018 (d) 0.048
25. The number of accidents in a year attributed to taxi drivers in a locality follows Poisson distribution with average 2. Out of 500 taxi drivers of that area, what is the number of drivers with at least 3 accidents in a year? (Given that $e = 2.718$) [PYQ-Sept., 2024]
 (a) 162 (b) 180
 (c) 201 (d) 190

26. If 5% of the electric bulbs manufactured by a company are defective, use Poisson distribution to find the probability that in a sample of 100 bulbs, 5 bulbs will be defective. [Give: $e^{-5} = 0.007$]

[MTP-Sept., 2025]

- (a) 0.1823 (b) 0.1723
(c) 0.1623 (d) 0.1923

27. A manufacture, who produces medicine bottles, finds that 0.1% of the bottles are defective. The bottles are packed in boxes containing 500 bottles. A drug manufacturer buys 100 boxes from the producer of bottles. Using Poisson distribution, find how many boxes will contains at least two defectives: [MTP-May 2025]

- (a) 7 (b) 13
(c) 9 (d) 11

28. The probability than a man aged 45 years will die within a year is 0.012. What is the probability that of 10 men, at least 9 will reach their 46th birthday? [Given; $e^{-0.12} = 0.88692$]

[MTP-May 2025]

- (a) 0.0935 (b) 0.9934
(c) 0.9335 (d) 0.9555

Normal Distribution

29. An example of bi-parametric continuous probability distribution. [MTP-May 2025]

- (a) Binomial (b) Poisson
(c) Normal (d) (a) and (b)

30. In a normal distribution, skewness is ___

[MTP-June 2024]

- (a) 0 (b) > 3
(c) < 3 (d) < 1

31. The total area of the normal curve is the

[MTP-June 2024]

- (a) one
(b) 50 percent
(c) 0.50
(d) any value between 0 and 1

32. The points of inflexion of the normal curve

$f(t) = \frac{1}{4\sqrt{2\pi}} e^{-\frac{(t-10)^2}{32}}$ are [MTP-June 2024]

- (a) 6, 14 (b) 5, 15
(c) 4, 16 (d) None of these

33. What is the mean of X having the following density function? [MTP-June 2024]

$$f(x) = \frac{1}{4\sqrt{2\pi}} e^{-\frac{(x-10)^2}{32}} \text{ for } -\infty < x < \infty$$

- (a) 4 (b) 10
(c) 40 (d) None of these

34. The Interval $(\mu - 3\sigma, \mu + 3\sigma)$ covers

[MTP-June, 2024]

- (a) 95% area of normal distribution
(b) 96% area of normal distribution
(c) 99% area of normal distribution
(d) All but not 0.27% area of a normal distribution

35. The mean deviation of normal distribution is approximately equal to [PYQ-Jan., 2025]

- (a) 3.14σ (b) 0.5σ
(c) 1.14σ (d) 0.8σ

36. The quartile deviation of a normal distribution with Mean 10 and Standard Deviation 4 is:

[PYQ-Sept., 2024]

- (a) 2.70 (b) 3.20
(c) 0.675 (d) 6.75

37. If the points of inflexion of a normal curve are 6 and 14, then standard deviation of the distribution is [PYQ-May, 2025]

- (a) 4 (b) 8
(c) 9.17 (d) 32

38. For a normal distribution, the ratio of mean deviation to the standard deviation is:

[PYQ-June, 2024]

- (a) 0.4 (b) 0.6
(c) 0.8 (d) 1.0

39. If X and Y are two independent normal variables with means 10 and 12, and standard deviations (S.D.) 3 and 4 respectively, then $(X + Y)$ is normally distributed with: [PYQ-Sept., 2024]

- (a) Mean = 22 and S.D. = 7
(b) Mean = 22 and S.D. = 25
(c) Mean = 22 and S.D. = 5
(d) Mean = 22 and S.D. = 49

40. If the points of inflexion of a normal curve are 40 and 60 respectively, then its mean is

[MTP-May 2025]

- (a) 40 (b) 45
(c) 50 (d) 60

41. X follow normal distribution with mean as 50 and variance as 100. What is $P(x \geq 60)$?

[Given $\phi(1) = 0.8413$]

[MTP-May, 2025]

- (a) 0.20 (b) 0.40
(c) 0.16 (d) 0.30

ANSWER KEY

1. (b) 2. (d) 3. (a) 4. (a) 5. (c) 6. (c) 7. (a) 8. (a) 9. (d) 10. (a)
11. (a) 12. (a) 13. (b) 14. (c) 15. (a) 16. (a) 17. (d) 18. (c) 19. (c) 20. (c)
21. (b) 22. (a) 23. (b) 24. (c) 25. (a) 26. (a) 27. (c) 28. (c) 29. (c) 30. (a)
31. (a) 32. (a) 33. (a) 34. (d) 35. (d) 36. (a) 37. (a) 38. (c) 39. (c) 40. (c)
41. (c)

HINTS & SOLUTIONS

1. (b) We know,

Binomial distribution is symmetric when $p = 0.5$

2. (d) According to the question, we have

Mean = 10 & S.D = 2

i.e., $m = np = 10$, S.D. = $\sqrt{npq} = 2$

Dividing both:

$$\frac{npq}{np} = \frac{4}{10}$$

$$q = 0.4$$

3. (a) Given, $n = 10$ & $p = 0.3$

Thus, $q = 1 - p = 1 - 0.3 = 0.7$

Therefore, Variance = $npq = 10 \times 0.3 \times 0.7 = 2.1$

4. (a) According to the question,

Number of trials; $n = 500$

Specific outcome (making 3 correct guesses): $x = 3$

Probability of success: $p = \frac{1}{2}$,

Probability of failure: $q = 1 - \frac{1}{2} = \frac{1}{2}$

Binomial distribution is given by the formula,

$$P(X = x) = {}^n C_x (p)^x (q)^{n-x}$$

$$P(X = x) = {}^5 C_3 \left(\frac{1}{2}\right)^3 \left(\frac{1}{2}\right)^{5-3} \left[\because {}^n C_r = \frac{n!}{r! \times (n-r)!} \right]$$

$$= \frac{5!}{2! \times 3!} \left(\frac{1}{8}\right) \left(\frac{1}{4}\right)$$

$$= \frac{10}{32} = \frac{5}{16} = 0.3125$$

5. (c) Given, $np = 20$... (i)

$$\sqrt{npq} = \sqrt{10} \quad \dots (ii)$$

$$\Rightarrow npq = 10$$

Put this value in eq. (i), we get

$$20q = 10$$

$$\Rightarrow q = \frac{1}{2}$$

$$\text{Thus, } p = \frac{1}{2}$$

Also, $np = 20$

$$\Rightarrow n \left(\frac{1}{2}\right) = 20$$

$$\Rightarrow n = 40$$

$$\text{Now, Mode} = (n + 1)p = 41 \times \frac{1}{2} = 20.5$$

Since, it is a non-integer, thus

$$\text{Mode} = 20$$

6. (c) According to question, we have

$$p = 3q$$

We know, $p + q = 1$

$$\Rightarrow 3q + q = 1$$

$$\Rightarrow 4q = 1$$

$$\Rightarrow q = \frac{1}{4}$$

$$\Rightarrow p = \frac{3}{4}$$

Now, probability of getting a head all the times is given by:

$$P(x=4) = {}^4C_4 \left(\frac{3}{4}\right)^4 \left(\frac{1}{4}\right)^0$$

$$= 1 \times \frac{81}{256} \times 1 = \frac{81}{256}$$

7. (a) Given;

- Variance = $npq = 0.2$
- Mean = $np = 0.6$
- Number of trials $n = 5$

Divide variance by mean:

$$\frac{npq}{np} = \frac{0.2}{0.6} = \frac{1}{3} = q$$

$$\text{So, } q = \frac{1}{3} \Rightarrow p = 1 - q = 1 - \frac{1}{3} = \frac{2}{3}$$

Probability of getting 3 successes:

$$P(X=3) = ({}^5C_3) p^3 q^2 = 10 \times \left(\frac{2}{3}\right)^3 \times \left(\frac{1}{3}\right)^2$$

$$= 10 \times \frac{8}{27} \times \frac{1}{9} = 10 \times \frac{8}{243} = \frac{80}{243} = \frac{80}{3^5}$$

8. (a) According to question, we have

$$q = 0.3, p = 1 - 0.3 = 0.7 \text{ and } n = 6$$

Therefore, the probability that out of a group of 6 candidates at least 4 passed the examination is given by;

$$P(x \geq 4) = {}^6C_4 (0.7)^4 (0.3)^2 + {}^6C_5 (0.7)^5 (0.3)^1 + {}^6C_6 (0.7)^6 (0.3)^0$$

$$\Rightarrow P(x \geq 4) = 0.324135 + 0.302526 + 0.117649$$

$$\Rightarrow P(x \geq 4) = 0.74 \text{ (Approx)}$$

9. (d) $E(X) = np$, $V(X) = np(1-p)$

$$\text{Given; } E(X) = 2, V(X) = \frac{4}{3}$$

$$\text{So, } np = 2$$

.....(i)

$$np(1-p) = \frac{4}{3}$$

Substitute (i) into (ii)

$$2(1-p) = \frac{4}{3}$$

$$1-p = \frac{2}{3}$$

$$\Rightarrow p = \frac{1}{3}$$

Now, from (i)

$$n \cdot \frac{1}{3} = 2$$

$$\Rightarrow n = 6$$

10. (a) According to question, we have

$$\text{Mean} = 10$$

$$\text{S.D} = 4$$

$$\text{Variance} = 16$$

Since, mean is always greater than variance.

$$\text{But } 10 < 16$$

Hence, the given data is not valid.

11. (a) Given, Mean = 20; S.D = 4

$$np = 20$$

$$\text{Variance} = npq = 4^2 = 16$$

$$\text{As, } npq = 16$$

$$\Rightarrow 20q = 16$$

$$\Rightarrow q = \frac{16}{20}$$

$$\Rightarrow q = \frac{4}{5}$$

$$\text{Thus, } p = 1 - q$$

$$\Rightarrow p = 1 - \frac{4}{5}$$

$$\Rightarrow p = \frac{1}{5}$$

$$\text{So, } np = 20$$

$$\Rightarrow n \times \frac{1}{5} = 20$$

$$\Rightarrow n = 100$$

Hence, the correct option is (a).

$$\text{i.e., } n = 100, p = \frac{1}{5}, q = \frac{4}{5}$$

12. (a) According to question, we have

$$p = \frac{1}{4}, q = \frac{3}{4}, n = 7$$

Therefore, the probability of hitting the target at least twice is given by;

$$p(x \geq 2) = 1 - p(x < 2)$$

$$= 1 - [p(x=0) + p(x=1)]$$

$$= 1 - [{}^7C_0 p^0 q^7 + {}^7C_1 p^1 q^6]$$

$$\begin{aligned}
&= 1 - \left[1 \times 1 \times \left(\frac{3}{4}\right)^7 + 7 \times \frac{1}{4} \times \left(\frac{3}{4}\right)^6 \right] \\
&= 1 - \left(\frac{3}{4}\right)^6 \left[\frac{3}{4} + \frac{7}{4} \right] \\
&= 1 - \left(\frac{3}{4}\right)^6 \times \frac{5}{2}
\end{aligned}$$

13. (b) Since, the number of trials (n) are very large and tends to be infinite however success (p) is very small.

Therefore, number of misprints per page of a thick book follows Poisson distribution.

14. (c) For Poisson distribution, mean = variance.
15. (a) We know,
Shape of Normal Distribution curve depends on its parameters.
16. (a) The Poisson model deals with the probability of successes, not failures.
17. (d) We know, Number of deaths by a rare disease \rightarrow This is a classic use case for Poisson distribution, especially when the event (death by rare disease) is rare and occurs over a period or region.
18. (c) Since 5 defective items out of 300 means a small p and large n , the distribution is best modeled by the Poisson distribution.

19. (c) According to question, we have

$$\begin{aligned}
\text{S.D} &= 2 \\
\text{Variance} &= m = 2^2 = 4 \\
\text{Mode} &= 4, 4 - 1 \\
&\Rightarrow 3 \text{ \& } 4
\end{aligned}$$

20. (c) Given information:

$$\begin{aligned}
P(X = 1) &= P(X = 2) \\
\text{Here, } X &\text{ is a Poisson variate.} \\
\text{Since } P(X = 1) &= P(X = 2) \\
\text{Thus, } \frac{m^1 \cdot e^{-m}}{1!} &= \frac{m^2 \cdot e^{-m}}{2!}
\end{aligned}$$

Here, m denotes the mean.

On simplification, we get

$$\begin{aligned}
\frac{m}{1} &= \frac{m^2}{2} \\
m &= 2
\end{aligned}$$

Thus, the mean of X is 2.

21. (b) $P(X = 1) = P(X = 2)$

$$\begin{aligned}
\Rightarrow P(X = x) &= \frac{e^{-m} m^x}{x!} \\
\Rightarrow \frac{e^{-m} \cdot m^1}{1!} &= \frac{e^{-m} \cdot m^2}{2!} \\
\Rightarrow \frac{m}{1} &= \frac{m^2}{2} \\
\Rightarrow m &= 2
\end{aligned}$$

22. (a) Given;

- Mean $m = 4$
- We need $P(X = 2)$

Using Poisson formula:

$$\begin{aligned}
P(X = 2) &= \frac{e^{-m} \cdot m^2}{2!} = \frac{e^{-4} \cdot 4^2}{2!} \\
&= \frac{e^{-4} \cdot 16}{2} = 8e^{-4} = \frac{8}{e^4}
\end{aligned}$$

23. (b) Given; $p = \frac{3}{100} = 0.03$ and $n = 100$

$$\text{Thus, } m = np = \frac{3}{100} \times 100 = 3$$

Now, the required probability is given by;

$$\begin{aligned}
P(X = 1) &= \frac{e^{-3} 3^1}{1!} \\
\Rightarrow P(X = 1) &= e^{-3} \times 3 \\
\Rightarrow P(X = 1) &= 0.149 \approx 0.15
\end{aligned}$$

24. (c) Given;

- $p = \frac{5}{100} = 0.05$
- $n = 100$
- So, $m = np = 5$

Using Poisson distribution, we get

$$\begin{aligned}
P(x = 10) &= \frac{e^{-5} \cdot 5^{10}}{10!} \\
e^{-5} &= 0.0067 \\
P(x = 10) &= \frac{0.0067 \cdot 9765625}{3628800} \approx 0.01803
\end{aligned}$$

25. (a) Given,

Total no. of taxi drivers (N) = 500

Mean (m) = 2

The probability of at least 3 accidents is given by

$$P(X \geq 3) = 1 - P(X < 3)$$

We know that, $P(X=x) = \frac{e^{-m}m^x}{x!}$

$$\Rightarrow P(X \geq 3) = 1 - P(X < 3)$$

$$\Rightarrow P(X \geq 3) = 1 - [P(0) + P(1) + P(2)]$$

$$\Rightarrow P(X \geq 3) = 1 - \left[\frac{e^{-2}2^0}{0!} + \frac{e^{-2}2^1}{1!} + \frac{e^{-2}2^2}{2!} \right]$$

$$\Rightarrow P(X \geq 3) = 1 - \frac{1}{(2.71828)^2} [1+2+2]$$

$$\Rightarrow P(X \geq 3) = 1 - \frac{1}{(2.71828)^2} [5]$$

$$\Rightarrow P(X \geq 3) = 1 - 0.06767$$

$$\Rightarrow P(X \geq 3) = 0.3233$$

Now, the number of drivers with at least 3 accidents in a year,

$$= N \times P(X \geq 3)$$

$$= 500 \times 0.3233$$

$$= 161.65 \approx 162$$

Therefore, the number of drivers with at least 3 accidents in a year are 162.

26. (a) According to question, we have

$$n = 100 \text{ \& } p = 5\% = \frac{5}{100}$$

$$\text{Thus, } m = np = 100 \times \frac{5}{100} = 5$$

Therefore, the required probability is given by;

$$P(X=5) = \frac{e^{-5} \cdot 5^5}{5!} = \frac{0.007 \times 3125}{120} = 0.18229$$

$$= 0.1823 \text{ (approx)}$$

27. (c) According to the question, we have

$$p = 0.1\% = \frac{0.1}{100} = 0.001, n = 500$$

$$m = n \times p = 500 \times 0.001 = 0.5$$

Now probability of at least 2 defectives:

$$P(X \geq 2) = 1 - P(X=0) - P(X=1)$$

$$P(X=0) = e^{-0.5} \frac{0.5^0}{0!} = e^{-0.5}$$

$$P(X=1) = e^{-0.5} \frac{0.5^1}{1!} = 0.5e^{-0.5}$$

$$P(X \geq 2) = 1 - e^{-0.5}(1 + 0.5) = 1 - 1.5e^{-0.5}$$

$$\text{Since, } e^{-0.5} \approx 0.6065,$$

$$P(X \geq 2) \approx 1 - 1.5(0.6065) = 1 - 0.9098 = 0.0902$$

For 100 boxes:

$$100 \times 0.0902 = 9.02 \approx 9$$

28. (c) According to the question, we have

$$p = 0.012$$

$$n = 10$$

$$m = np$$

$$= 10 \times 0.012 = 0.12$$

Now, the probability that at least 9 men survive i.e.,

9 reached/survive or 10 reached/survive

or

1 died or 0 died

$$= P(X=0) + P(X=1)$$

$$= \frac{e^{-0.12} \cdot (0.12)^0}{0!} + \frac{e^{-0.12} \cdot (0.12)^1}{1!}$$

$$= 0.88692[1 + 0.12]$$

$$= 0.9934 \text{ (Approx)}$$

29. (c) A bi-parametric continuous distribution means it has two parameters and is continuous

- **Binomial** → discrete
- **Poisson** → discrete
- **Normal** → continuous with two parameters (μ, σ^2)

30. (a) We know,

Normal distribution is perfectly symmetric, so skewness = 0.

31. (a) The total probability under a normal curve equals 1.

32. (a) On comparing the given curve with standard curve, we get

$$\text{Means} = \mu = 10$$

$$\text{\& } \sigma = 4$$

Therefore, the required points of inflexion are;

$$\mu \pm \sigma = 10 \pm 4 = 6, 14$$

33. (a) On comparing the given curve with standard curve

$$\text{i.e., } f(x) = \frac{1}{\sigma\sqrt{2\pi}} e^{-\frac{(x-\mu)^2}{2\sigma^2}}$$

Therefore, Mean = $\mu = 10$

34. (d) In a normal distribution, the interval ($\mu \pm 3\sigma$) cover approximately 99.73% of the data.

So, the interval ($\mu - 3\sigma, \mu + 3\sigma$) excludes only about 0.27% of the total area (0.135% in each tail).

35. (d) We know,

$$5 \cdot \text{M.D.} = 4 \cdot \text{S.D.} \Rightarrow \frac{\text{M.D.}}{\text{S.D.}} = \frac{4}{5} = 0.8$$

36. (a) Using the formula:

$$\text{Q.D.} = \frac{4}{6} \times \text{S.D.} = \frac{4}{6} \times 4 = 2.66$$

$$= 2.70 \text{ (Approximation)}$$

37. (a) Given; Points of inflexion of a normal curve are 6 and 14

Let σ be the standard deviation and μ be the mean, then

According to the question,

$$\mu - \sigma = 16 \quad \dots(i)$$

$$\mu + \sigma = 14 \quad \dots(ii)$$

Subtracting (i) and (ii), we get

$$\mu - \sigma - (\mu + \sigma) = 16 - 14$$

$$\Rightarrow -2\sigma = -8$$

$$\Rightarrow \sigma = 4$$

Therefore, the Standard Deviation is 4.

38. (c) We know,

$$\Rightarrow 5 \cdot \text{M.D.} = 4 \cdot \text{S.D.} \Rightarrow \frac{\text{M.D.}}{\text{S.D.}} = \frac{4}{5} = 0.8$$

39. (c)

- Means of $X + Y$:

$$\mu = 10 + 12 = 22$$

- Standard deviation of $X + Y$ (since independent variables):

$$\sigma = \sqrt{3^2 + 4^2} = \sqrt{9 + 16} = \sqrt{25} = 5$$

40. (c) Given: Points of inflexion of normal curve are 40 and 60.

Let σ be the standard deviation and μ be the mean, then According to the question,

$$\mu - \sigma = 40 \quad \dots(i)$$

$$\mu + \sigma = 60 \quad \dots(ii)$$

Adding (i) and (ii),

$$\mu - \sigma = 40$$

$$\mu + \sigma = 60$$

$$2\mu = 100$$

$$\Rightarrow \mu = \frac{100}{2}$$

$$\Rightarrow \mu = 50$$

Therefore, the required mean is 50.

41. (c) According to question, we have

$$\mu = 50 \text{ and } \sigma^2 = 100$$

$$\Rightarrow \sigma = 10$$

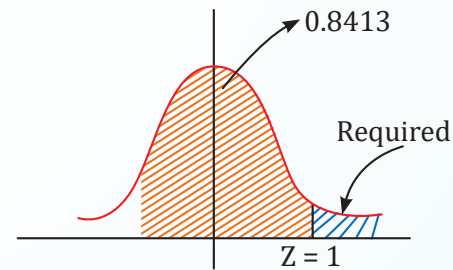

$$Z = \frac{x - \mu}{\sigma}$$

$$Z = \frac{x - 50}{10}$$

$$P(x \geq 60) = P\left(Z \geq \frac{60 - 50}{10}\right)$$

$$= P(Z \geq 1)$$

$$= 1 - 0.8413$$

$$= 0.1587$$



Chapter Wrap-up Test

Ready to test your knowledge?

You've got 15 questions and 20 minutes - go for it!

1. The means of a binomial distribution with parameter n and p is

(a) $n(1 - p)$ (b) $np(1 - p)$

(c) np (d) $\sqrt{np(1 - p)}$

2. The wages of workers of a factory follows

(a) Binomial distribution

(b) Poisson distribution

(c) Normal distribution

(d) Chi-square distribution

3. For a Poisson variate x , $P(x = 1) = P(x = 2)$ what is the mean of x ?

(a) 1 (b) $\frac{3}{2}$

(c) 2 (d) $\frac{5}{2}$

4. With a probability of 3% encountering defective bolts, determine the expected number of defective bolts in a total of 30 randomly selected packets.

(a) 1.5 (b) 1.225

(c) 1.0 (d) None of these

5. The means of the Binomial distribution

$B\left(4, \frac{1}{3}\right)$ is equal to

(a) $\frac{3}{5}$ (b) $\frac{4}{3}$

(c) $\frac{8}{3}$ (d) $\frac{3}{4}$

6. If X is a binomial variate with $p = \frac{1}{3}$, for the experiment of 90th trials, then the standard deviation is equal to

(a) $-\sqrt{5}$ (b) $\sqrt{5}$

(c) $2\sqrt{5}$ (d) $\sqrt{15}$

7. In a city with a crime rate of 60%, the probability that among a group of 5 incidents, at least 4 are reported accurately is

(a) $\frac{1}{3125}$ (b) $\frac{1053}{3125}$

(c) $\frac{810}{3125}$ (d) $\frac{243}{3125}$

8. A coin with probability for head as $\frac{1}{5}$ is tossed 100 times, then the standard deviation of the number of heads turned up is

(a) 3 (b) 4

(c) 7 (d) 10

9. In a certain manufacturing process, 5% of the tools produced turn out to be defective. Find the probability that in a sample of 40 tools, at most 2 will be defective.

Given, $e^{-2} = 0.135$

(a) 0.555 (b) 0.932

(c) 0.785 (d) 0.675

10. If $x \sim B(5, p)$ and $p(x = 2) = 0.4362$ and $P(x = 3) = 0.2181$, then $p =$

(a) $\frac{3}{4}$ (b) $\frac{1}{3}$

(c) $\frac{2}{3}$ (d) $\frac{1}{4}$

11. If the points of inflexion of a normal curve and 40 and 60 respectively, then its mean deviation is

(a) 8 (b) 4.5

(c) 5 (d) 6

12. What is the mean of X having the following density function?

$$f(x) = \frac{1}{4\sqrt{2\pi}} e^{-\frac{(x-10)^2}{32}} \text{ for } -\infty < x < \infty$$

(a) 4 (b) 10

(c) 40 (d) None of the above

13. If 5% of the electric bulbs manufactured by a company are defective, use Poisson distribution to find the probability that in a sample of 100 bulbs, 5 bulbs will be defective. [Given $e^{-5} = 0.007$]

- (a) 0.1823 (b) 0.1723
(c) 0.1623 (d) 0.1923

14. Mean and variance of a Binomial variate are 4 and $\frac{4}{3}$ respectively, then $P(x \geq 1)$ will be:

- (a) $\frac{728}{729}$ (b) $\frac{1}{729}$
(c) $\frac{723}{729}$ (d) None

15. The probability of a man hitting the target is $\frac{1}{4}$. If he fires 7 times, the probability of hitting the target at least twice is

- (a) $1 - \left(\frac{5}{2}\right)\left(\frac{3}{4}\right)^6$
(b) $1 - \frac{15}{2}\left(\frac{3}{4}\right)^6$
(c) $1 - \left(\frac{5}{6}\right) \cdot 3^5$
(d) $1 - \left(\frac{3}{4}\right)^6$

ANSWER KEY

1. (c) 2. (c) 3. (c) 4. (a) 5. (b) 6. (c) 7. (b) 8. (b) 9. (d) 10. (b)
11. (a) 12. (b) 13. (a) 14. (a) 15. (a)



Correlation and Regression

Cheat Sheet by Anurag Sir

CORRELATION

- Degree of association between two variables.
- Correlation can be negative, positive or zero.
- $-1 \leq r \leq 1$

- For direct relation between x and y
 $x \uparrow y \uparrow$ or $x \downarrow y \downarrow$
 r is positive.
- For inverse relation between x and y
 $x \downarrow y \uparrow$ or $x \uparrow y \downarrow$
 r is negative.

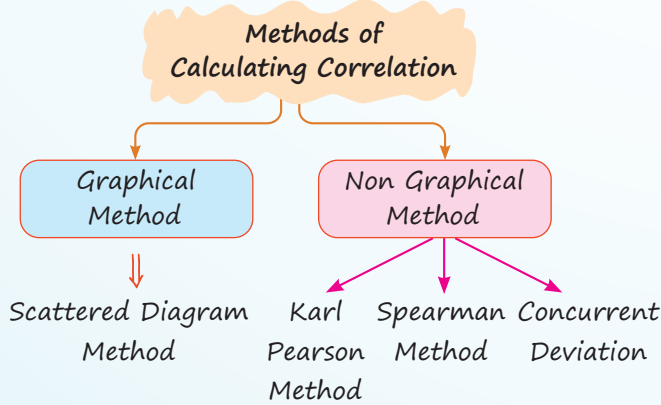
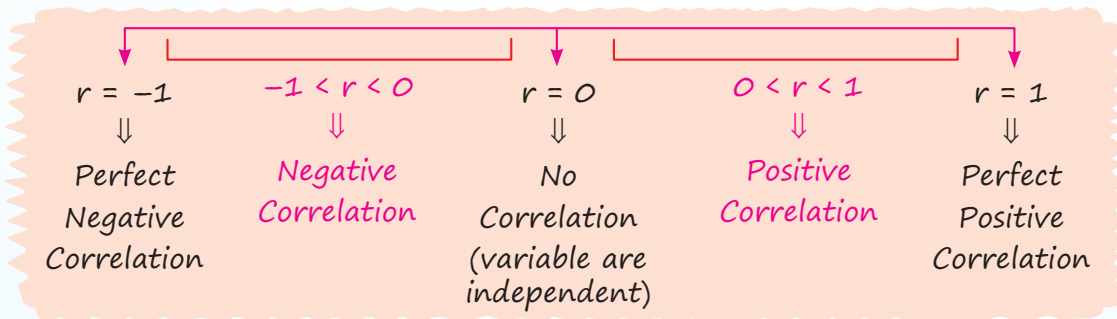

Scattered Diagram Method

Plot the values of two variable on graph:

For straight line
 (lower left to upper right)

$r = 1$

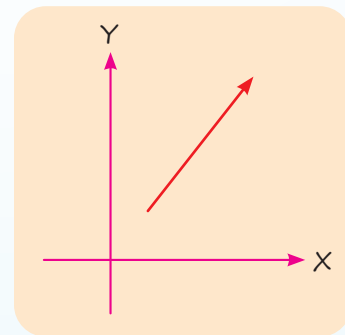

For straight line
 (upper left to lower right)

$r = -1$

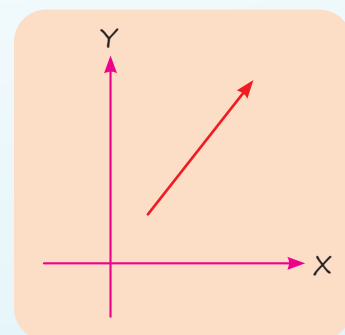

$$0 < r < 1$$

(No straight line)

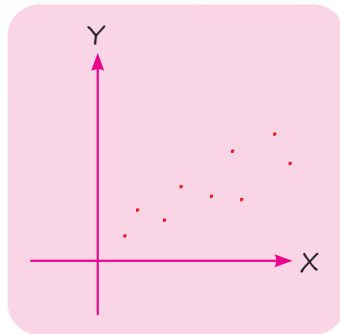

$$-1 < r < 0$$

(No straight line)

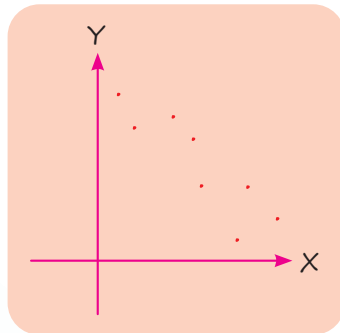

$$r = 0$$

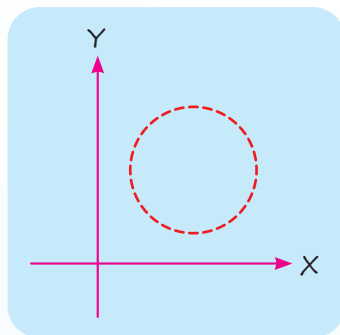

$$r = 0$$

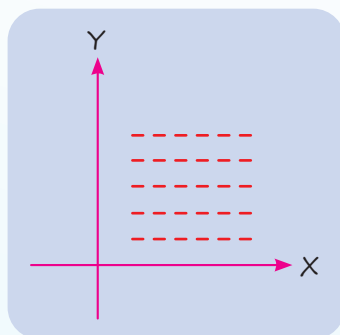

$$r = 0$$

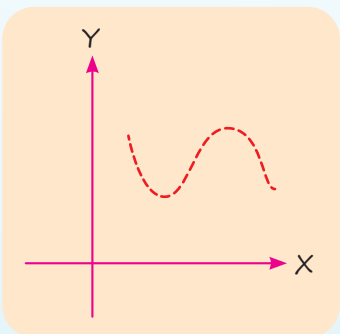

- Exact magnitude can not be calculated in scattered diagram method.

Karl Pearson's Coefficient Correlation

- Covariance

$$\begin{aligned} &= \text{cov}(x, y) \\ &= \frac{\sum(x_i - \bar{x}) \cdot (y_i - \bar{y})}{N} \end{aligned}$$

- Cov(x, y) can be real number (negative, positive and zero)

- Cov(x, y) does not change with origin but it changes with change of scale.

$$r = \frac{\text{cov.}(x, y)}{\sigma_x \sigma_y}$$

Or

$$r = \frac{\sum(x_i - \bar{x}) \cdot (y_i - \bar{y})}{N \sigma_x \sigma_y}$$

$$r = \frac{\sum(x_i - \bar{x}) \cdot (y_i - \bar{y})}{\sqrt{\sum(x_i - \bar{x})^2} \times \sqrt{\sum(y_i - \bar{y})^2}}$$

Or

$$r = \frac{\sum xy - \frac{\sum x \times \sum y}{N}}{\sqrt{\sum x^2 - \frac{(\sum x)^2}{N}} \sqrt{\sum y^2 - \frac{(\sum y)^2}{N}}}$$

- Correlation does not change with change of origin

i.e. $U_i = x_i - A$ and $V_i = y_i - B$
then,

$$r = \frac{\sum UV - \frac{\sum U \times \sum V}{N}}{\sqrt{\sum U^2 - \frac{(\sum U)^2}{N}} \sqrt{\sum V^2 - \frac{(\sum V)^2}{N}}}$$

- Correlation does not change with change of scale (provided scale is positive)

- When scale is negative, the sign of correlation may change but magnitude does not change

e.g. $r(x, y) = 0.5$

If $U_i = 2x_i$ and $V_i = 4y_i$

then $r(U_i, V_i) = (+)(+) 0.5 = 0.5$

e.g. $r(x, y) = 0.6$

If $U_i = -2x_i$ and $V_i = 3y_i$

then $r(U, V) = (-)(+) 0.6 = -0.6$

e.g. If $r(x, y) = 0.7$

and $U_i = -2x_i$ and $V_i = -4y_i$

then $r(U, V) = (-)(-) 0.7 = (+)0.7$

Spearman's Rank Correlation

- This method used for qualitative characters and level of agreements and disagreements between opinions of judges.
- When no numbers repeat

$$r = 1 - \frac{6\sum D^2}{N^3 - N}$$

- When some numbers repeat

$$r = 1 - \frac{6 \left[\sum D^2 + \frac{1}{12}(m_1^3 - m_1) + \frac{1}{12}(m_2^3 - m_2) \right]}{N^3 - N}$$

$$\sum D = 0$$

X	Y	R ₁	R ₂	D = R ₁ - R ₂	D ²
				0	

Concurrent Deviation Method

Concurrent Deviation



When x and y both increase or both decrease

$$r = \pm \sqrt{\pm \left(\frac{2c - m}{m} \right)}$$

where, c = Total no. of concurrent deviation

$$m = n - 1$$

	x	y		Concurrent Deviation
+	10	12	+	Yes (+)
+	12	15	-	No (-)
-	15	14	+	No (-)
+	14	15	+	Yes (+)
+	16	18	+	Yes (+)
-	12	20	+	No (-)

$$c = 2$$

$$m = 6 - 1 = 5$$

$$r = \sqrt{\frac{2(2) - 5}{5}}$$

$$r = \sqrt{\frac{-1}{5}} = -\sqrt{\frac{1}{5}}$$

- When $\frac{2c - m}{m}$ is negative

then (-1) sign will be taken out from $\sqrt{\text{sign}}$.

Bivariate Frequency Distribution Table

Maths/ Stats	0-5	5-10	10-15	15-20	Total
0-10	2	5	1	0	8
10-20	3	2	3	4	12
20-30	4	1	2	6	13
Total	9	8	6	10	33

Frequency Distribution of Marks of Maths

Marks	No. of Students
0-10	8
10-20	12
20-30	13
	33

This is called Marginal Distribution.

Frequency Distribution of Marks in Maths when score in stats is '5-10'

Marks	No. of Students
0-10	5
10-20	2
20-30	1
	8

This is called Conditional Distribution.

For Bivariate Distribution Table of "m×n"

Total cells = $m \times n$

Total marginal distribution = 2

Total conditional distribution = $m + n$

Coefficient of determination
 $= r^2 = \frac{\text{Explained variance}}{\text{Total variance}}$

Coefficient of Non-determination
 $= 1 - r^2$

Regressions

- Establishing mathematical relation between two variables (Independent and Dependent)
- Prediction of Dependent variable.
- For linear regression least square method is used.

There are two linear Regression lines

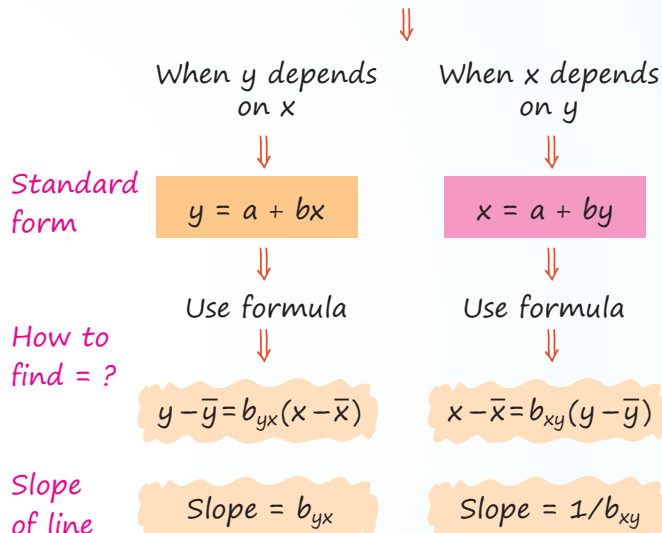

b_{yx} and b_{xy} are known as regression coefficients.

Calculation of Regression Coefficients

$b_{yx} = \frac{\text{cov}(x, y)}{\sigma_x^2}$	$b_{xy} = \frac{\text{cov}(x, y)}{\sigma_y^2}$
$b_{yx} = \frac{\sum(x_i - \bar{x})(y_i - \bar{y})}{\sum(x_i - \bar{x})^2}$	$b_{xy} = \frac{\sum(x_i - \bar{x})(y_i - \bar{y})}{\sum(y_i - \bar{y})^2}$
$b_{yx} = \frac{\sum xy - \frac{\sum x \sum y}{N}}{\sum x^2 - \frac{(\sum x)^2}{N}}$	$b_{xy} = \frac{\sum xy - \frac{\sum x \sum y}{N}}{\sum y^2 - \frac{(\sum y)^2}{N}}$
$b_{yx} = r \frac{\sigma_y}{\sigma_x}$	$b_{xy} = r \frac{\sigma_x}{\sigma_y}$

$$r = \begin{matrix} + \\ \text{or} \\ - \end{matrix} \sqrt{b_{yx} \times b_{xy}}$$

- ' y ' will be positive if both b_{yx} and b_{xy} are positive.
- ' r ' will be negative if both b_{yx} and b_{xy} are negative.
- $b_{yx} \times b_{xy} \leq 1$

$$r \leq \frac{b_{yx} + b_{xy}}{2}$$

<p>If Regression line y on x is : $ax + by + c = 0$ then $b_{yx} = \frac{-a}{b}$</p>	<p>If Regression line x on y is : $Ax + By + c = 0$ then $b_{xy} = \frac{-B}{A}$</p>
---	---

Two Regression lines intersect each other at (\bar{x}, \bar{y})

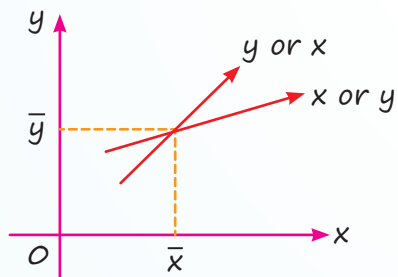

Regression coefficients does not change with change of origin

$U_i = x_i - A$ and $V_i = y_i - B$
then, $b_{yx} = b_{vu}$ and $b_{xy} = b_{uv}$

Regression coefficient changes with change of scale

$U_i = ax_i + b$ and $V_i = cy_i + d$

So, $b_{vu} = \frac{c}{a} \times b_{yx}$

or

$b_{vu} = \frac{\text{Scale of } y}{\text{Scale of } x} \times b_{yx}$

When two lines are perpendicular

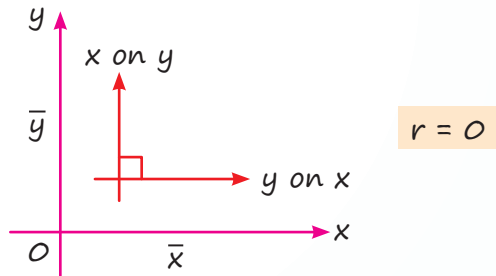

When two lines are coincident

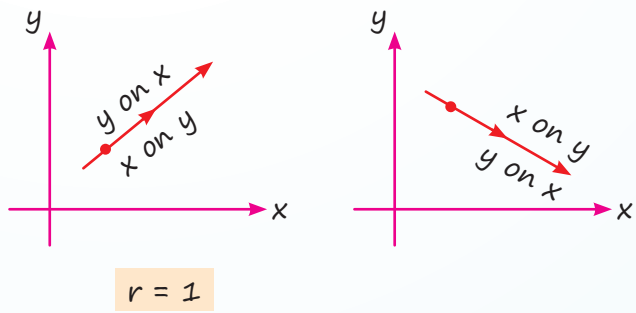

QUESTIONS

Correlation

- In case of “Insurance companies profits” and “The number of claims they have to pay”, there exists a **[PYQ-Sep. 2024]**
 - Positive correlation
 - Negative correlation
 - No correlation
 - It cannot be predicted.
- When $r = 1$, all the points in a scatter diagram would be: **[MTP-Jan. 2025]**
 - On a straight line directed from lower left to upper right
 - On a straight line directed from upper left to lower right

- On a straight line
 - Both (a) and (b).
- Spearman’s correlation coefficient is used to check **[PYQ-Jun. 2024]**
 - The scattering of the data
 - The relationship in variables
 - The median of a data
 - The range of a data
 - What is spurious correlation? **[MTP-Jan. 2025]**
 - It is a bad relation between two variables.
 - It is very low correlation between two variables.
 - It is the correlation between two variables having no causal relation.
 - It is a negative correlation.

5. For 9 college students group, the sum of squares of differences in ranks for History and Hindi marks was found to be 62, then what is the value of rank correlation coefficient? [PYQ-May, 2025]
- (a) 1 (b) 0.48
(c) 0.52 (d) 0.87
6. For a group of 10 students the sum of squares of difference in ranks for Physics and Chemistry marks was 60, what is the value of rank correlation coefficient. (Choose the nearest value) [PYQ-Jun. 2024]
- (a) 0.636 (b) 0.725
(c) 0.698 (d) 0.842
7. The correlation coefficient between X and Y is 0.8. If we add a number 10 in X-variable and subtracted 20 from Y-variable, then the new correlation coefficient will be [PYQ-May 2025]
- (a) 0.4 (b) 0.6
(c) 0.9 (d) 0.8
8. If $\text{Cov}(X, Y) = 2.15$, $S_x = 1.30$, $S_y = 2.50$ then correlation coefficient is [PYQ-Jun. 2024]
- (a) -0.66 (b) 0.66
(c) 0.76 (d) 0.99
9. If for two variable x and y , the covariance, variance of x and variance of y are 40, 16 and 256 respectively, what is the value of the correlation coefficient? [MTP-Jan. 2025]
- (a) 0.01 (b) 0.625
(c) 0.4 (d) 0.5
10. If the rank correlation coefficient between marks in Management and Mathematics for a group of students is 0.6 and the sum of the squares of the difference in rank is 66. Then what is the number of students in the group? [MTP-Jan. 2025]
- (a) 9 (b) 10
(c) 11 (d) 12
11. The coefficient of rank correlation of marks obtained by 10 students in English and Economics was found to be 0.5, it was later discovered that the difference in the ranks in the two subjects by one student was wrongly taken as 3 instead of 7. Find the correct coefficient of rank correlation. [MTP-Jun. 2024]
- (a) 0.514 (b) 0.364
(c) 0.15 (d) 0.260
12. For n pairs of observations, the coefficient of concurrent deviation is calculated as $\frac{1}{\sqrt{3}}$ if there are six concurrent deviations then $n =$ [PYQ-Nov. 2022]
- (a) 11 (b) 10
(c) 9 (d) 8
13. Correlation coefficient is _____ of the units of measurement. [MTP-Jun. 2024]
- (a) independent (b) dependent
(c) both (d) none of these
14. The range of the coefficient of correlation is [PYQ-Jun. 2024]
- (a) between -1 and 1
(b) between -1 and 1 including 1
(c) between -1 and 1 including -1
(d) between -1 and 1 including -1, 1
15. If the coefficient of correlation between two variables is 0.8, the percentage of variation unaccounted for is [MTP-Jan. 2025]
- (a) 70% (b) 30%
(c) 51% (d) 36%
16. The correlation between two variables x and y is found to be 0.4. What is the correlation between $2x$ and $(-y)$? [MTP-Jun. 2024]
- (a) 0.4 (b) -0.4
(c) 0.6 (d) None of these
17. Correlation coefficient between X and Y will be negative when [MTP-Jan. 2025]
- (a) X and Y are decreasing
(b) X is increasing, Y is decreasing
(c) X and Y are increasing
(d) None of these.
18. Two variables X and Y are related as $4x + 3y = 7$, then correlation between x and y is [MTP-Jan. 2025]
- (a) Perfect positive (b) Perfect negative
(c) Zero (d) None of these
19. The variance of two variables 'x' and 'y' are 16 and 25 and covariance between 'x' and 'y' is 18.5. Another two variables 'u' and 'v' are defined as $u = \frac{(x-3)}{2}$ and $v = \frac{(y-2)}{3}$ then coefficient of correlation between 'u' and 'v' is: [PYQ-Sep. 2024]
- (a) 0.85 (b) 0.875
(c) 0.90 (d) 0.925

20. If the relation between x and u is $3x + 4u + 7 = 0$ and the correlation coefficient between x and y is -0.6 , then what is the correlation coefficient between u and y ? [MTP-Jan. 2025]

- (a) -0.6 (b) 0.8
(c) 0.6 (d) -0.8

Regression

21. The two lines of regression become identical when [MTP-Sep. 2024]

- (a) $r = 1$ (b) $r = -1$
(c) $r = 0$ (d) (a) or (b)

22. If one regression coefficient is _____ unity, then the other must be _____ unity. [MTP-Sep. 2024]

- (a) more than, more than
(b) less than, less than
(c) more than, less than
(d) positive, negative

23. If $y = 3x + 4$ is the regression line of y on x and the arithmetic mean of x is -1 , what is the arithmetic mean of y ? [MTP-Sep. 2024]

- (a) 1 (b) -1
(c) 7 (d) None of these

24. If $r = 0.6$, then the coefficient of non-determination is [MTP-Sep. 2024]

- (a) 0.4 (b) -0.6
(c) 0.36 (d) 0.64

25. Which one of the following statement is correct regarding limit of the two regression coefficient? [PYQ-Sep. 2024]

- (a) No limit.
(b) Must be positive.
(c) One positive and the other negative.
(d) Product of the regression coefficients must be numerically less than unity.

26. If $r = 0.8$, $b_{yx} = 0.6$, $b_{xy} = 0.5$, $\bar{x} = 5$ and $\bar{y} = 3$, then the regression equation y on x is [PYQ-Jan. 2025]

- (a) $y = 0.96x - 3.7$ (b) $y = 0.6x - 6.0$
(c) $y = 0.8x$ (d) $y = 0.6x$

27. For lines of regression $4x - 2y = 3$ and $2x - 3y = 5$, find b_{xy} . [MTP-Sep. 2024]

- (a) $\frac{1}{8}$ (b) $\frac{1}{2}$
(c) $\frac{1}{12}$ (d) None of these

28. When both the regression coefficient are $b_{xy} = 0.7$ and $b_{yx} = 0.8$ respectively, then the coefficient between x and y is [PYQ-May, 2025]

- (a) 0.75 (b) 0.56
(c) 0.28 (d) 0.87

29. The correlation coefficient between X and Y is 0.2 and $\text{var}(X) = 5 \text{Var}(Y)$, then regression coefficient of X on Y is [PYQ-Jan. 2025]

- (a) $\sqrt{5}$ (b) $\frac{1}{5}$
(c) $\frac{1}{\sqrt{5}}$ (d) 5

30. Given $x = 2y + 4$ and $y = kx + 6$ are the two lines of regression x on y and y on x respectively. If the value of correlation coefficient (r) is 0.5 , then the value of k is [PYQ-May, 2025]

- (a) $\frac{1}{8}$ (b) $\frac{1}{4}$
(c) $\frac{1}{3}$ (d) $\frac{1}{2}$

31. Which of the following statement is correct?

[PYQ-Sep. 2024]

- (a) If two Regression lines coincide with each other, there is no correlation between the variates.
(b) Regression coefficients are independent of origin but not of scale.
(c) The regression lines of two independent variables are parallel to each other.
(d) None of these.

32. If the regression lines are $3x - 4y + 8 = 0$ and $4x - 3y = 1$, then the correlation coefficient between x and y is [PYQ-Jun. 2024]

- (a) $\frac{3}{4}$ (b) $\frac{1}{4}$
(c) $\frac{3}{8}$ (d) $\frac{1}{8}$

33. The two lines of regression are given by $8x + 10y = 25$ and $16x + 5y = 12$ respectively. If the variance of x is 25 , what is the standard deviation of y ?

[MTP-Sep. 2024]

- (a) 16 (b) 8
(c) 64 (d) 4

ANSWER KEY

- | | | | | | | | | | |
|---------|---------|---------|---------|---------|---------|---------|---------|---------|---------|
| 1. (b) | 2. (a) | 3. (b) | 4. (c) | 5. (b) | 6. (a) | 7. (d) | 8. (a) | 9. (b) | 10. (b) |
| 11. (d) | 12. (b) | 13. (a) | 14. (d) | 15. (d) | 16. (b) | 17. (b) | 18. (b) | 19. (d) | 20. (c) |
| 21. (d) | 22. (c) | 23. (a) | 24. (d) | 25. (d) | 26. (d) | 27. (b) | 28. (a) | 29. (c) | 30. (a) |
| 31. (b) | 32. (a) | 33. (b) | | | | | | | |

HINTS & SOLUTIONS

1. (b) The number of claims that an insurance company has to pay increases, the profits of the company are likely to decrease.

When the number of claims is high, the insurance company has to pay more money in claims, which reduces the money available for profits.

So, as the number of claims increases, the profits of the company decrease, resulting in a negative correlation between the two variables.

Hence, the correct answer is option (b) i.e., Negative Correlation.

2. (a) We know that

If data points lie from lower left to upper right then it is positive correlation such that $0 < r < 1$.

If data points lie from upper left to lower right then it is negative correlation such that

$$-1 < r < 0$$

If $r = 1$ there is perfect correlation and all the points lie on a straight line directed from lower left to upper right.

If $r = 0$ there is no correlation.

Therefore, for $r = 1$ all the points in a scatter diagram would lie on a straight line directed from lower left to upper right.

Hence, option (a) is correct.

3. (b) We know,

Spearman's correlation coefficient is used to check the relationship in variables.

4. (c) We know that,

Spurious correlation is the correlation between two variables having no causal relation.

5. (b) We know that,

$$R = 1 - \frac{6\sum d^2}{n(n^2 - 1)}$$

$$\Rightarrow R = 1 - \frac{6 \times 62}{9(9^2 - 1)}$$

$$\Rightarrow R = 1 - \frac{6 \times 62}{9 \times 80}$$

$$\Rightarrow R = 0.48 \text{ (approx.)}$$

6. (a) We know,

Spearman's rank correlation coefficient is given by

$$r_R = 1 - \frac{6\sum d_i^2}{n(n^2 - 1)}$$

$$\Rightarrow r_R = 1 - \frac{6 \times 60}{10(10^2 - 1)}$$

$$\Rightarrow r_R = 0.636$$

7. (d) We know that,

The coefficient of correlation is independent of change of origin.

Thus, on adding a number 10 in X-variable and subtracting 20 from Y-variable, the correlation coefficient will remain same.

Therefore, the new correlation coefficient will be 0.8.

8. (a) Given, $\text{Cov}(X, Y) = -2.15$, $S_x = 1.30$, $S_y = 2.50$

Therefore, correlation coefficient is given by

$$r = \frac{\text{Cov}(X, Y)}{S_x \cdot S_y}$$

$$\Rightarrow r = \frac{-2.15}{1.30 \times 2.5}$$

$$\Rightarrow r = -0.66$$

9. (b) We know that,

$$\text{Correlation coefficient, } r = \frac{\text{cov}(x, y)}{s_x \times s_y}$$

where, r = Correlation coefficient

$\text{cov}(x, y)$ = Covariance of x and y

S_x = Standard deviation of x

S_y = Standard deviation of y

Also, Standard deviation = $\sqrt{\text{Variance}}$

$$\Rightarrow \text{Standard deviation of } x, S_x = \sqrt{16} = 4$$

$$\Rightarrow \text{Standard deviation of } y, S_y = \sqrt{256} = 16$$

Calculating correlation coefficient, we get

$$(r) = \frac{40}{4 \times 16} = \frac{40}{64} = 0.625$$

Hence, the correct option is (b) i.e. 0.625.

10. (b) Spearman's rank correlation coefficient is given by

$$\rho = 1 - \frac{6\sum d^2}{n(n^2 - 1)}$$

Given, $\rho = 0.6$, $\sum d^2 = 66$

$$\Rightarrow 0.6 = 1 - \frac{6 \times 66}{n(n^2 - 1)}$$

$$\Rightarrow 0.4 = \frac{6 \times 66}{n(n^2 - 1)}$$

$$\Rightarrow \frac{6 \times 66}{0.4} = n(n^2 - 1)$$

$$\Rightarrow \frac{6 \times 66 \times 10}{4} = n(n^2 - 1)$$

$$\Rightarrow 900 = n(n - 1)(n + 1)$$

$$\Rightarrow 10(10 - 1)(10 + 1) = n(n - 1)(n + 1)$$

$$\Rightarrow 10 \times 9 \times 11 = n(n - 1)(n + 1)$$

Thus, the value of n is 10.

Hence, the correct option is (b).

11. (d) We know,

$$R = 1 - \frac{6\sum d^2}{n(n^2 - 1)}$$

$$\Rightarrow 0.5 = 1 - \frac{6\sum d^2}{10(10^2 - 1)}$$

$$\Rightarrow \frac{6\sum d^2}{990} = 1 - 0.5 = 0.5$$

$$\Rightarrow \sum d^2 = 82.5$$

$$\Rightarrow \sum d^2_{\text{correct}} = 82.5 - 3^2 + 7^2 = 122.5$$

Therefore, the correct coefficient of rank correlation is given by

$$R = 1 - \frac{6 \times 122.5}{990}$$

$$\Rightarrow R = 0.257 = 0.260 \text{ (approx.)}$$

12. (b) We know that,

$$r_c = \sqrt{\frac{2c - m}{m}}$$

$$\Rightarrow \frac{1}{\sqrt{3}} = \sqrt{\frac{2(6) - m}{m}}$$

$$\Rightarrow \frac{1}{\sqrt{3}} = \sqrt{\frac{12 - m}{m}}$$

$$\Rightarrow \frac{1}{3} = \frac{12 - m}{m}$$

$$\Rightarrow m = 36 - 3m$$

$$\Rightarrow 4m = 36$$

$$\Rightarrow m = 9$$

Thus, $n = m + 1 = 9 + 1 = 10$

13. (a) We know,

Correlation coefficient is independent of the units of measurement.

14. (d) We know,

The range of the coefficient of correlation always lies between -1 and 1 , including both the limiting values i.e., $-1 \leq r \leq 1$.

15. (d) Given, Coefficient of correlation between two variables (r) = 0.8 .

Therefore, the percentage of variation unaccounted for is given by

$$\begin{aligned} 1 - r^2 &= 1 - (0.8)^2 \\ &= 1 - 0.64 \\ &= 0.36 = 36\% \end{aligned}$$

16. (b) Given, Correlation between two variables x and $y = 0.4$

Let $u = 2x$ and $v = -y$

Here, the signs of u and v are opposite, thus the correlation between $2x$ and $(-y)$ is given by $r_{uv} = -r_{xy} = -0.4$.

17. (b) A negative correlation describes the extent to which two variables move in opposite directions. For example, for two variables, X and Y , an increase in X is associated with a decrease in Y . A negative correlation coefficient is also referred to as an inverse correlation.

Hence, the correct option is (b) i.e., X is increasing, Y is decreasing.

18. (b) We know that for equation $ay = bx + c$, if sign of x and y are of opposite signs, then correlation is perfectly negative.

$$\text{Given } 4x + 3y = 7,$$

$$\Rightarrow 3y = -4x + 7$$

Here sign of x and y are opposite, so correlation is perfect negative.

Hence, option (b) is correct.

19. (d) We have,

$$\sigma_x^2 = 16, \sigma_y^2 = 25, \text{Cov}(x, y) = 18.5$$

$$\Rightarrow \sigma_x = 4, \sigma_y = 5$$

We know,

$$r_{xy} = \frac{\text{cov}(x, y)}{\sigma_x \sigma_y}$$

$$\Rightarrow r_{xy} = \frac{18.5}{4 \times 5} = 0.925$$

$$\Rightarrow r_{uv} = 0.925$$

20. (c) Given;

$$3x + 4u + 7 = 0$$

$$\Rightarrow u = \left(\frac{-3}{4}\right)x - \left(\frac{-7}{4}\right)$$

Thus, perfect negative correlation exists between x and y , $r_{xy} = (-0.6)$

Correlation between u and $y = r_{uy}$

$$= \frac{(-0.6) \times \left(\frac{-3}{4}\right)}{\left(\frac{3}{4}\right)} = 0.6$$

Hence, the correct answer is option (c) i.e. 0.6.

21. (d) We know that,

The two lines of regression coincide or become identical when $r = 1$ or $r = -1$.

If $r = 0$, then the regression lines are perpendicular to each other.

22. (c) We know that,

If one regression coefficient is more than unity, then the other must be less than unity.

23. (a) Given;

Regression line of y on x is given by

$$y = 3x + 4$$

$$\Rightarrow \bar{y} = 3\bar{x} + 4$$

$$\Rightarrow \bar{y} = 3(-1) + 4$$

$$\Rightarrow \bar{y} = 1$$

24. (d) Given; $r = 0.6$

Thus, the coefficient of non-determination is given by,

$$\begin{aligned} 1 - r^2 &= 1 - (0.6)^2 \\ &= 1 - 0.36 = 0.64 \end{aligned}$$

25. (d) We know,

$$b_{xy} \cdot b_{yx} < 1$$

i.e., Product of the regression coefficients must be numerically less than unity.

26. (d) Given; $r = 0.8$, $b_{yx} = 0.6$, $b_{xy} = 0.5$, $\bar{x} = 5$ and $\bar{y} = 3$

We know that,

Regression equation of y on x is given by

$$y - \bar{y} = b_{yx}(x - \bar{x})$$

$$\Rightarrow y - 3 = 0.6(x - 5)$$

$$\Rightarrow y - 3 = 0.6x - 3$$

$$\Rightarrow y = 0.6x$$

27. (b) Given lines of regression;

$$4x - 2y = 3 \text{ and } 2x - 3y = 5$$

Let $4x - 2y = 3$ be the regression line of x on y , then

$$4x = 2y + 3$$

$$\Rightarrow x = \frac{1}{2}y + \frac{3}{4}$$

$$\Rightarrow b_{xy} = \frac{1}{2}$$

Now, let $2x - 3y = 5$ be the regression line of y on x , then

$$3y = 2x - 5$$

$$\Rightarrow y = \frac{2}{3}x - \frac{5}{3}$$

$$\Rightarrow b_{yx} = \frac{2}{3}$$

Now, $b_{xy} \cdot b_{yx} = \frac{1}{2} \times \frac{2}{3} = \frac{1}{3} < 1$ which hold the condition.

Therefore, $b_{xy} = \frac{1}{2}$.

28. (a) We know that,

$$\begin{aligned} r^2 &= b_{xy} \times b_{yx} \\ \Rightarrow r^2 &= (0.8) \times (0.7) \\ \Rightarrow r^2 &= 0.56 \\ \Rightarrow r &= \sqrt{0.56} \\ \Rightarrow r &= 0.75 \text{ (approx)} \end{aligned}$$

Therefore, the correlation coefficient between x and y is 0.75.

29. (c) Given; $\text{Var}(X) = 5 \text{ Var}(Y)$

$$\Rightarrow \frac{\sigma_x^2}{\sigma_y^2} = 5 \quad \Rightarrow \frac{\sigma_x}{\sigma_y} = \sqrt{5}$$

We know that,

$$\begin{aligned} b_{xy} &= r \frac{\sigma_x}{\sigma_y} \\ \Rightarrow b_{xy} &= 0.2 \times \sqrt{5} \\ \Rightarrow b_{xy} &= \frac{1}{5} \times \sqrt{5} \\ \Rightarrow b_{xy} &= \frac{1}{\sqrt{5}} \end{aligned}$$

30. (a) Given;

$x = 2y + 4$ is the line of regression x on y

$$\Rightarrow b_{xy} = 2$$

Also, $y = kx + 6$ is the line of regression y on x

$$\Rightarrow b_{yx} = k$$

Also, $r = 0.5$

We know that,

$$\begin{aligned} r^2 &= b_{xy} \cdot b_{yz} \\ \Rightarrow (0.5)^2 &= 2 \times k \\ \Rightarrow k &= \frac{(0.5)^2}{2} \\ \Rightarrow k &= 0.125 \\ \Rightarrow k &= \frac{1}{8} \end{aligned}$$

31. (b) Regression coefficients are independent of origin but not of scale.

Hence, option (b) is correct.

32. (a) We know,

$$4y = 3x + 8$$

$$\Rightarrow y = \frac{3x}{4} + 2$$

$$\text{Also, } 4x = 3y + 1$$

$$\Rightarrow x = \frac{3y}{4} + \frac{1}{4}$$

Thus, the correlation coefficient between x and y is calculated as

$$\begin{aligned} r^2 &= b_{yx} \cdot b_{xy} \\ \Rightarrow r^2 &= \frac{3}{4} \times \frac{3}{4} \\ \Rightarrow r^2 &= \frac{9}{16} \quad \Rightarrow r = \frac{3}{4} \end{aligned}$$

33. (b) Given regression lines;

$$8x + 10y = 25 \text{ and } 16x + 5y = 12$$

$$\Rightarrow y = \frac{-8}{10}x + \frac{25}{10}$$

$$\Rightarrow b_{yx} = -\frac{8}{10} \quad \dots\text{(i)}$$

Now,

$$16x = -5y + 12$$

$$\Rightarrow x = -\frac{5}{16}x + \frac{12}{16}$$

$$\Rightarrow b_{xy} = -\frac{5}{16} \quad \dots\text{(ii)}$$

$$\text{Thus, } b_{yx} \cdot b_{xy} = \frac{-8}{10} \times \frac{-5}{16} = \frac{1}{4} < 1$$

$$\Rightarrow r^2 = \frac{1}{4}$$

$$\Rightarrow r = -\frac{1}{2}$$

$$\text{We know, } b_{yx} = r \frac{\sigma_y}{\sigma_x}$$

$$\Rightarrow \frac{-8}{10} = -\frac{1}{2} \times \frac{\sigma_y}{5} \Rightarrow \sigma_y = 8$$



Chapter Wrap-up Test

Ready to test your knowledge?

You've got 15 questions and 20 minutes - Go for it!

1. Spearman's correlation coefficient is used to check
 - (a) The scattering of the data
 - (b) The relationship in variables
 - (c) The median of a data
 - (d) The range of a data.
2. The two lines of regression become identical when
 - (a) $r = 1$
 - (b) $r = -1$
 - (c) $r = 0$
 - (d) (a) or (b)
3. If the coefficient of correlation between two variables is 0.8, then the percentage of variation unaccounted for is
 - (a) 70%
 - (b) 30%
 - (c) 51%
 - (d) 36%
4. Which one of the following statement is correct regarding limit of the two regression coefficients?
 - (a) No limit.
 - (b) Must be positive.
 - (c) One positive and the other negative.
 - (d) Product of the regression coefficients must be numerically less than unity.
5. Out of the following, which one affects the regression co-efficient?
 - (a) Change of origin only
 - (b) Change of scale only
 - (c) Change of scale & origin both
 - (d) Neither change of origin nor change of scale.
6. The regression equation are $2x + 3y + 1 = 0$ and $5x + 6y + 1 = 0$, then mean of x and y respectively are
 - (a) -1, -1
 - (b) -1, 1
 - (c) 1, -1
 - (d) 2, 3

7. The variance of two variables 'x' and 'y' are 16 and 25 and covariance between 'x' and 'y' is 18.5. Another two variables 'u' and 'v' are defined as $u = \frac{(x-3)}{2}$ and $v = \frac{(y-2)}{3}$ then coefficient of correlation between 'u' and 'v' is:
 - (a) 0.85
 - (b) 0.875
 - (c) 0.90
 - (d) 0.925
8. For lines of regression $4x - 2y = 3$ and $2x - 3y = 5$, find b_{xy} .
 - (a) $\frac{1}{8}$
 - (b) $\frac{1}{2}$
 - (c) $\frac{1}{12}$
 - (d) None of these
9. If $r = \frac{1}{2}$, $\Sigma xy = 120$, $\sigma_y = 8$, $\Sigma x^2 = 90$, where x and y are the deviation from mean, then the value of n is
 - (a) 10
 - (b) 16
 - (c) 19
 - (d) 100
10. The coefficient of rank correlation of marks obtained by 10 students in English and Economics was found to be 0.5, it was later discovered that the difference in the ranks in the two subjects by one student was wrongly taken as 3 instead of 7. Find the correct coefficient of rank correlation.
 - (a) 0.514
 - (b) 0.364
 - (c) 0.15
 - (d) 0.260
11. The coefficient of rank correlation between the ranking of following 6 students in two subjects Mathematics and Statistics is:

Mathematics	Statistics
3	6
5	4
8	9
4	8
7	1
10	2

- (a) -0.26 (b) 0.35
 (c) 0.38 (d) 0.20

12. The coefficient of concurrent deviation for P pairs of observations was found to be $\frac{1}{\sqrt{3}}$.

If the number of concurrent deviations was found to be 6, then the value of P is

- (a) 10
 (b) 9
 (c) 8
 (d) None of these

13. The two lines of regression are given by $8x + 10y = 25$ and $16x + 5y = 12$ respectively. If the variance of x is 25, what is the standard deviation of y ?

- (a) 16 (b) 8
 (c) 64 (d) 4

14. The equations of two lines of regression are $4x + 3y + 7 = 0$ and $3x + 4y + 8 = 0$. Find the correlation coefficient between x and y .

- (a) -0.75 (b) 0.25
 (c) -0.92 (d) 1.25

15. Determine the coefficient of correlation between x and y series.

	x series	y series
Number of items	15	15
Arithmetic mean	25	18
sum of square of deviation of mean	136	138

Sum of product deviation of x, y series from mean = 122

- (a) -0.89 (b) 0.89
 (c) 0.69 (d) -0.69

ANSWER KEY

1. (b) 2. (d) 3. (d) 4. (d) 5. (b) 6. (c) 7. (d) 8. (b) 9. (a) 10. (d)
 11. (a) 12. (a) 13. (b) 14. (a) 15. (b)



Cheat Sheet by Anurag Sir

Index Number

- Statistical tool
- Measure changes in *variable*

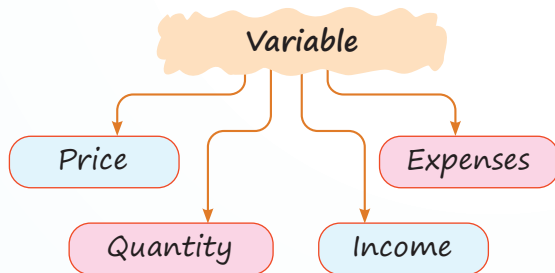

- Compare changes over time or places.
- Current year value is compared with base year value.
- Expressed in percentage.

Denoted by P_{01}

0 ⇒ Base year; 1 ⇒ Current year



Challenges in Construction of Index Number

- Selection of Base year.
- Selection of product.
- Selection of prices.
- Selection of formula.

- Selection of weight.

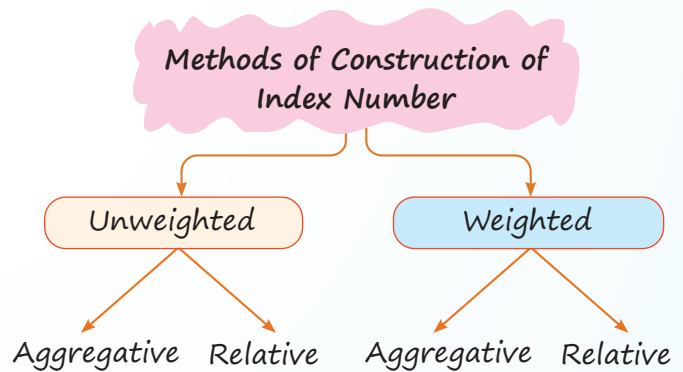

Simple Aggregative Method

$$P_{01} = \frac{\sum P_1}{\sum P_0} \times 100$$

Simple Relative Method

$$P_{01} (AM) = \frac{\sum \left(\frac{P_1}{P_0} \times 100 \right)}{N} \times 100$$

$$P_{01} (GM) = \left[\frac{\sum \log \left(\frac{P_1}{P_0} \times 100 \right)}{N} \right] \times 100$$

Weighted Aggregative Method

$$\frac{\sum P_1 (w)}{\sum P_0 (w)} \times 100 \quad \downarrow \text{Weight}$$

- Quantity is taken as weight
- Different statistician take different year quantity

Laspeyre (Base Year Quantity)

$$P_{01} = \frac{\sum p_1 q_0}{\sum p_0 q_0} \times 100$$

Paasche's (Current Year Quantity)

$$P_{01} = \frac{\sum p_1 q_1}{\sum p_0 q_1} \times 100$$

Fishers (Geometric mean of L & P)

$$P_{01} = \sqrt{L \times P}$$

$$P_{01} = \sqrt{\frac{\sum p_1 q_0}{\sum p_0 q_0} \times \frac{\sum p_1 q_1}{\sum p_0 q_1}} \times 100$$

Marshall Edgeworth

(Average of Base year and correct year quantity)

$$P_{01} = \frac{\sum p_1 \left(\frac{q_0 + q_1}{2} \right)}{\sum p_0 \left(\frac{q_0 + q_1}{2} \right)}$$

Dorbish and Bowley

(Average of L & P)

$$P_{01} = \frac{L + P}{2} = \left[\frac{\frac{\sum p_1 q_0}{\sum p_0 q_0} + \frac{\sum p_1 q_1}{\sum p_0 q_1}}{2} \right] \times 100$$

Weighted Relative Method

$$P_{01} = \frac{\sum w_i \left(\frac{p_1}{p_0} \times 100 \right)}{\sum w_i}$$

and $P_{01} = AL = \left[\frac{\sum w_i \log \left(\frac{p_1}{p_0} \times 100 \right)}{\sum w_i} \right]$

Quantity Index (Volume Index)

Measure changes in consumptions, productive or sales over a period of time or some other character.

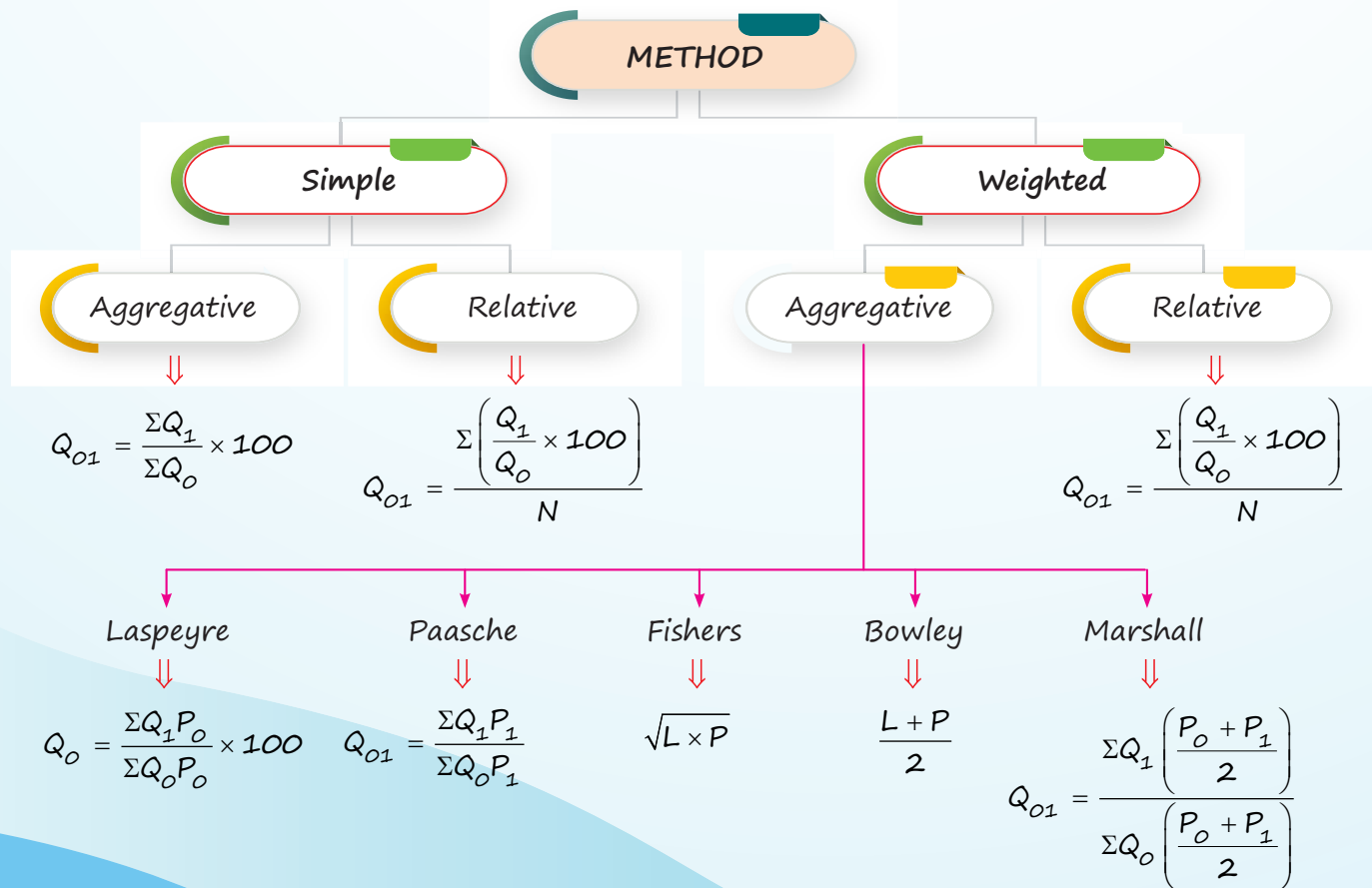

Volume Index

$$V_{01} = \frac{\sum p_1 q_1}{\sum p_0 q_0} \times 100$$

Group Index

$$\frac{\sum w_i I_i}{\sum w_i}$$

where, I_i = Index of particular item

Consumer Price Index

(Cost of Living Index)

Changes in **Cost of Living**

- ❑ Representative market
(Basket of goods and services)
- ❑ Food, clothing, rent, health and other daily expenses.

$$CPI = \frac{\text{Total exp. in C.Y.}}{\text{Total exp. in B.Y.}}$$

(Laspeyre formula)

or

$$CPI = \frac{\sum w_i I_i}{\sum w_i}$$

(Weighted formula)

Deflated Value (Real Value)

$$\text{Deflated value} = \frac{\text{Current value}}{\text{Price index}}$$

Index Number

Year	Index	Wages	Real wages
2010	100	500	$\frac{500}{100} \times 100 = 500$
2011	110	600	$\frac{600}{110} \times 100 = 545$
2012	140	800	$\frac{800}{140} \times 100 = 571$
2013	200	900	$\frac{900}{200} \times 100 = 450$

Shifting of Base Year

- ❑ When old base year is not relevant.
- ❑ Changes in economic policies, global and domestic market structure.

e.g.

Year	Index (Base 2010)	New Index (Base 2012)
2010	100	$\frac{100}{120} \times 100 = 83$
2011	110	$\frac{110}{120} \times 100 = 92$
2012	120	$\frac{120}{120} \times 100 = 100$
2013	140	$\frac{140}{120} \times 100 = 117$

Shifted price index

$$= \frac{\text{Original price index}}{(\text{Index of the year where it has to be shifted})} \times 100$$

Splicing of Two Index Series

- ❑ Combining two index series with different base year.
- ❑ Used when:
 - ❖ Changes in quantity weight,
 - ❖ Change in method of calculation,
 - ❖ New product introduction.

Year	(Base 2010) Old Index	(Base 2012) Revised Index	(Base 2010) Spliced Index	(Base 2012) Spliced Index
2010	100		100	$\frac{100}{150} \times 100 = 67$
2011	120		120	$\frac{100}{150} \times 120 = 80$
2012	150	100	150	100
2013		130	$\frac{150}{100} \times 130 = 195$	130
2014		160	$\frac{150}{100} \times 160 = 240$	160

Test of Adequacy

1. Unit Test

Formula should be independent of units of price and quantity, due to change in units index number should not change.

- This test is satisfied by all methods except "Simple Aggregative Method".

2. Time Reversal Test

Formula should work both ways "Forward" and "Backward"

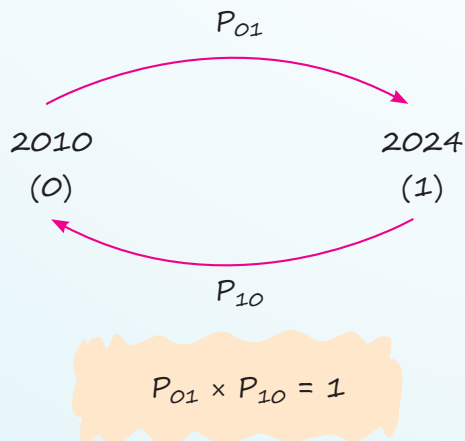

- Satisfied by
 - ◆ Fishers (GM)

- ◆ Simple Relative (GM)
- ◆ Weighted Relative (GM)
- ◆ Marshall Edgeworth

3. Factor Reversal Test

$$P_{01} \times Q_{01} = V_{01}$$

or

$$P_{01} \times Q_{01} = \frac{\sum p_1 q_1}{\sum p_0 q_0}$$

Satisfied by "Fishers"

4. Circular Test

Extension of time reversal

$$P_{01} \times P_{12} \times P_{21} = 1$$

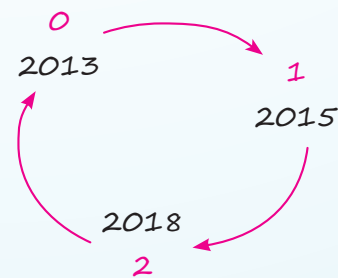

- Satisfied by
 - ◆ Simple price relative (GM)
 - ◆ Weighted aggregative (Fixed Weight)

QUESTIONS

- During a certain period, the cost of living index goes up from 110 to 200 and the salary of a worker is also raised from ₹330 to ₹500, then in the real terms, the raise in the salary is effectively- **[PYQ-Sep., 2024]**
 - Gain by Rs. 50
 - Gain by Rs. 75
 - Loss by Rs. 90
 - Loss by Rs. 50
- The consumer price index for the year 2023 is 273 with 2010 as base year. The average monthly wages of industrial worker in year 2023 is Rs. 8,190. What is the real wage? **[PYQ-Sep., 2024]**
 - Rs. 2,800
 - Rs. 3,000
 - Rs. 3,200
 - Rs. 3,400
- The cost of living is always **[PYQ-Jan., 2021; MTP-Nov., 2023]**
 - Price index number
 - Quantity index number
 - Weighted index number
 - Value index number
- Which index measures the change from month to month in the cost of a representative basket of goods and services of the type bought by a typical household? **[MTP-Apr., 2023]**
 - Retail price index
 - Laspeyre's index
 - Fisher's index
 - Paasche's index
- When the prices for quantities consumed of all commodities are changing in the same ratio, then the index numbers due to Laspeyre's and Paasche's will be **[PYQ-Jan., 2021]**
 - Equal
 - Unequal
 - Reciprocal of Marshall Edgeworth's Index number
 - Reciprocal of Fisher's index number
- In price index, when a new commodity is required to be added, which of the following index is used? **[MTP-Apr., 2023]**
 - Shifted price index
 - Splicing price index
 - Deflating price index
 - Value price index
- An index number constructed to measure the relative change in the price of an item or a group of items is called: **[PYQ-Dec., 2023]**
 - Quantity index number
 - Price index number
 - Volume index number
 - Composite index number
- The index number of prices for a country at a given date is 250. In comparison to the base period price, the price of all commodities in the country has increased by _____ times. **[PYQ-Jun. 2023]**
 - 1.25
 - 1.5
 - 2
 - 2.5
- Which of the following index uses the method of average of base year & current year? **[MTP-Jan., 2025]**
 - Paasche's Index
 - Laspeyre's Index
 - Marshall-Edgeworth Index
 - Fisher's Index
- Which of the following is not a test of adequacy in the context of index numbers? **[PYQ-Jun., 2024]**
 - Unit test
 - Square test
 - Circular test
 - Factor reversal test
- Fisher's index number is called as ideal index number because it satisfies **[MTP-Apr., 2023]**
 - Factor reversal test
 - Time reversal test
 - Both factor and time reversal test
 - Circular test
- Circular test is satisfied by which of the following index? **[MTP-Nov., 2023]**
 - Laspeyre's index
 - Paasche's index
 - Fisher's index
 - Simple geometric mean of price relatives

13. From the following chain base index numbers based on 2015, find out new chain base index number for the year 2022 by shifting the base year 2019. **[PYQ-May, 2025]**

Year	Index No. (Base 2015)
2015	100
2016	105
2017	95
2018	85
2019	120
2020	110
2021	130
2022	150

- (a) 125 (b) 180
(c) 100 (d) 150
14. If the prices of all commodities in the base year are twice the values of the respective commodities in the current year, then the Fisher's ideal index number is equal to **[PYQ-Jun, 2024]**
- (a) 200 (b) 50
(c) 25 (d) 400
15. From the following data, construct the index number by Laspeyre's method:
 $\Sigma p_1q_1 = 99$, $\Sigma p_0q_1 = 76$, $\Sigma p_0q_0 = 73$, $\Sigma p_1q_0 = 96$
[PYQ-Dec, 2022]
- (a) 136.25 (b) 131.51
(c) 130.88 (d) 96
16. From the following data, construct the index number by Laspeyre's method:
 $\Sigma P_1Q_1 = 100$, $\Sigma P_0Q_1 = 86$, $\Sigma P_0Q_0 = 83$, $\Sigma P_1Q_0 = 106$
[MTP-Apr, 2023]
- (a) 130.36 (b) 131.51
(c) 130.59 (d) 127.71
17. The test of shifting the base is called **[PYQ-Jun, 2022]**
- (a) Unit test (b) Time reversal test
(c) Factor reversal test (d) Circular test
18. Let p_0 and p_1 be the prices of a commodity in the base and current year respectively. The price relative with respect to base year is **[PYQ-Jun, 2022]**

- (a) $\frac{p_1}{p_0}$ (b) $\frac{p_0}{p_1}$

- (c) $\frac{p_1 - p_0}{p_0}$ (d) $\frac{p_1 - p_0}{p_1}$

19. The Laspeyre's index number is a weighted aggregate method by taking _____ as weight. **[PYQ-Jun, 2022]**
- (a) quantity consumed in the base year
(b) quantity consumed in the current year
(c) value of items consumed in the base year
(d) value of items consumed in the current year.
20. If the 2018 index with base 2015 is 250 and 2015 index with base 2012 is 150, the index 2018 on base 2012 will be: **[MTP-Nov, 2023]**
- (a) 800 (b) 375
(c) 600 (d) None
21. Fisher index number is _____ of Laspeyres and Paasche's Index Number. **[MTP-Nov, 2023]**
- (a) A.M (b) G.M
(c) H.M (d) None of these
22. If Laspeyre's index is A and Fisher's index is B. Find the value of Paasche's index. **[MTP-Jun, 2023]**
- (a) $\frac{B^2}{A}$ (b) $\frac{A^2}{B}$
(c) $\frac{A}{2B}$ (d) $\frac{2B}{A}$
23. If Fisher's index = 150 and Paasche's Index = 144, then Laspeyre's index is **[MTP-Apr, 2023]**
- (a) 147 (b) 156.25
(c) 104.17 (d) 138
24. If Laspeyre's index number is 250 and paasche's index number is 160, then Fisher's index number is **[MTP-Nov, 2023]**
- (a) 200 (b) 400
(c) 250 (d) 196
25. If $\Sigma p_nq_n = 249$, $\Sigma p_0q_0 = 150$, $\Sigma p_nq_0 = 145$ and Paasche's index number = 150, then Fisher's ideal price index number is **[PYQ-May, 2025]**
- (a) 75 (b) 126.9
(c) 120.62 (d) 171
26. If $\Sigma p_1q_1 = 249$, $\Sigma p_0q_0 = 150$, Paasche's index number = 150 and Dorbish and Bowely's index number = 145, then the Fisher's ideal index number is **[MTP-Nov, 2023]**
- (a) 175 (b) 144.91
(c) 145.97 (d) None

27. The simple index number for the current year using simple aggressive method for the following data: **[MTP-May, 2022]**

Commodity base	Base Year Price (P_0)	Base Year Price (P_1)
Wheat	80	100
Rice	100	150
Gram	120	250
Pulses	200	300

- (a) 200 (b) 150
(c) 240 (d) 160
28. The cost-of-living index number in year 2015 and 2018 were 97.5 and 115 respectively. The salary of CA Jitendra in 2015 was 195000. How much additional salary was required for him in 2018 to maintain the same standard of living as in 2015? **[MTP-May, 2022]**
- (a) 30,000
(b) 40,000
(c) 35,000
(d) 45,000
29. If the prices of all the goods change in the same ratio, then **[PYQ-Jan., 2025]**
- (a) Laspeyre's index and Paasche's index number are not equal.
(b) Laspeyre's index and Paasche's index number are equal.
(c) Laspeyre's index is greater than Paasche's index number.
(d) Laspeyre's index is less than Paasche's index number.

30. Weighted geometric mean of relative formula satisfies _____ test while Factor Reversal test is satisfied by _____. **[PYQ-Jun. 2023]**

- (a) Time Reversal, Fisher's Ideal index
(b) Time Reversal, Laspeyres's index
(c) Factor Reversal, Paasche's index
(d) Factor Reversal, Fisher's Ideal index

31. The gross monthly pay of an employee was ₹15,000 in the year 2020. The consumer price index number in 2023 is 155 with 2020 as the base year. If the employee is to be rightly compensated, what dearness allowance is required to be paid?

- (a) ₹8,000
(b) ₹8,250
(c) ₹8,500
(d) ₹8,750

32. From the year 2013 to 2023, the Consumer Price Index (CPI) number increased from 135 to 180. During this period, the salary of employees as per pay commission recommendations was received from ₹23,000 to ₹29,500.

In real terms, an employee should get the following additional amount (upto the nearest whole number) to maintain their previous standard of living: **[PYQ-Dec. 2023]**

- (a) ₹1,168
(b) ₹666
(c) ₹909
(d) ₹6,500

ANSWER KEY

1. (d) 2. (b) 3. (c) 4. (a) 5. (a) 6. (b) 7. (b) 8. (b) 9. (c) 10. (b)
11. (c) 12. (d) 13. (a) 14. (b) 15. (b) 16. (d) 17. (d) 18. (a) 19. (a) 20. (b)
21. (b) 22. (a) 23. (b) 24. (a) 25. (c) 26. (b) 27. (d) 28. (c) 29. (b) 30. (a)
31. (b) 32. (a)

HINTS & SOLUTIONS

1. (d) Given: The cost of living index goes up from 110 to 200 and the salary of a worker is also raised from Rs.330 to Rs.500

$$\text{i.e., Real wages}_I = \frac{330}{110} \times 100 = \text{Rs. } 300$$

$$\text{Now, Real wages}_{II} = \frac{500}{200} \times 100 = \text{Rs. } 250$$

Clearly, it is loss of Rs. 50.

2. (d) Real wage is given by

$$\text{Real wage} = \frac{8190}{273} \times 100 = \text{Rs. } 3000$$

3. (c) The cost of living is always weighted index number.

4. (a) We know that,

Retail Price index is a list of the prices of typical goods and it shows how much the cost of living changes from month to month.

5. (a) We know that,

When the prices for quantities consumed of all commodities are changing in the same ratio, then the index numbers due to Laspeyre's and Paasche's will be equal.

6. (b) We know,

In price index, when a new commodity is required to be added, Splicing price index is used.

7. (b) A Price Index Number measures the relative change in prices over time for a single item or group of items.

8. (b) Base period = 100

Current period = 250

Increase = 250 - 100 = 150

Increase in times = $\frac{150}{100} = 1.5$

9. (c) We know,

$$L_0 = \frac{q_0 + q_1}{2}$$

Thus, Marshall-Edgeworth Index uses the method of average of base year and current year.

10. (b) We know,

Square test is not the test of adequacy in the context of index number.

11. (c) We know that,

Fisher's index number is called as ideal index number because it satisfies both factor and time reversal test.

12. (d) We know that,

Circular test is not satisfied by Laspeyre's, Paasche's or Fisher's Index but satisfied by Simple geometric mean of price relatives.

13. (a) We have

Year	Index No. (Base 2015)
2015	100
2016	105
2017	95
2018	85
2019	120
2020	110
2021	130
2022	150

Therefore, the new chain base index number for the year 2022 by shifting the base year 2019 is given by

$$\frac{150}{120} \times 100 = 125$$

14. (b) Given, $p_0 = 2p_1$

$$\begin{aligned} P_{01} \text{ (Laspeyre's)} &= \frac{\sum p_1 q_0}{\sum p_0 q_0} \times 100 \\ &= \frac{\sum p_1 q_0}{2 \sum p_1 q_0} \times 100 = 50 \end{aligned}$$

$$\begin{aligned} \text{Also } P_{01} \text{ (Paasche's)} &= \frac{\sum p_1 q_1}{\sum p_0 q_1} \times 100 \\ &= \frac{\sum p_1 q_1}{2 \sum p_1 q_1} \times 100 = 50 \end{aligned}$$

Thus, Fisher's = $\sqrt{50 \times 50} = 50$

15. (b) Given,

$$\Sigma p_1q_1 = 99, \Sigma p_0q_1 = 76, \Sigma p_0q_0 = 73, \Sigma p_1q_0 = 96$$

Laspeyre's index number is given by

$$\begin{aligned} P_{01}(L) &= \frac{\Sigma p_1q_0}{\Sigma p_0q_0} \times 100 \\ &= \frac{96}{73} \times 100 = 131.51 \text{ (approx)} \end{aligned}$$

16. (d) Given:

$$\Sigma P_1Q_1 = 100, \Sigma P_0Q_1 = 86, \Sigma P_0Q_0 = 83,$$

$$\Sigma P_1Q_0 = 106$$

We know,

$$\begin{aligned} \text{Laspeyre's index is given by } &\frac{\Sigma P_1Q_0}{\Sigma P_0Q_0} \times 100 \\ &= \frac{106}{83} \times 100 = 127.71 \end{aligned}$$

17. (d) We know,

The test of shifting the base is called Circular test.

18. (a) The price relative with respect to base year

$$\text{is given by } \frac{p_1}{p_0}.$$

19. (a) The Laspeyre's index number is a weighted aggregate method by taking quantity consumed in the base year as weight.

20. (b) Given,

If the 2018 index with base 2015 = 250 and 2015 index with base 2012 = 150

To find : The index 2018 on base 2012

Using chain base index :

Year	Index	Chain Base Index
2012	100	100
2015	150	$\frac{150 \times 100}{100} = 150$
2018	250	$\frac{250 \times 150}{100} = 375$

'Or'

$$\text{Index 2018 on base 2012, } P_{20} = \frac{P_{21} \times P_{10}}{100}$$

$$\Rightarrow \frac{250 \times 150}{100} \Rightarrow 375$$

Therefore, the index 2018 on base 2012 will be 375.

21. (b) We know,

Fisher's index

$$= \sqrt{\text{Laspeyre's index} \times \text{Paasche's index}}$$

Therefore, Fisher index number is geometric mean of Laspeyres and Paasches Index Number.

22. (a) Given,

Laspeyre's index = A and Fisher's index = B

We know,

$$\text{Fisher's index} = \sqrt{\text{Laspeyre's} \times \text{Paasche's}}$$

$$\Rightarrow B = \sqrt{A \times \text{Paasche's}}$$

$$\Rightarrow B^2 = A \times \text{Paasche's}$$

$$\Rightarrow \text{Paasche's index} = \frac{B^2}{A}$$

23. (b) We know,

$$\text{Fisher's index} = \sqrt{\text{Laspeyre's} \times \text{Paasche's}}$$

$$\Rightarrow 150 = \sqrt{\text{Laspeyre's} \times 144}$$

$$\Rightarrow (150)^2 = \text{Laspeyre's} \times 144$$

$$\Rightarrow \text{Laspeyre's} = \frac{(150)^2}{144}$$

$$\Rightarrow \text{Laspeyre's} = 156.25$$

24. (a) Given, Laspeyre's Index number = 250 and Paasche's Index number = 160

We know,

$$\text{Fisher's index} = \sqrt{250 \times 160}$$

$$\Rightarrow \text{Fisher's index} = 5 \times 4 \times 10$$

$$\Rightarrow \text{Fisher's index} = 200$$

25. (c) Given: $\Sigma p_nq_n = 249, \Sigma p_0q_0 = 150, \Sigma p_nq_0 = 145$ and Paasche's index number = 150

$$P_{01} = \frac{\Sigma p_nq_0}{\Sigma p_0q_0} \times 100$$

$$\Rightarrow P_{01} = \frac{145}{150} \times 100 \Rightarrow P_{01} = 96.66$$

We know that,

$$\text{Fisher's index (F)} = \sqrt{\text{Laspeyre's} \times \text{Paasche's}}$$

$$\Rightarrow F = \sqrt{96.66 \times 150}$$

$$\Rightarrow F = 120.62 \text{ (approx)}$$

26. (b) We know,

Dorbish and Bowely's index number

$$= \frac{\text{Laspeyre's index} + \text{Paasche's index}}{2}$$

$$\Rightarrow 145 = \frac{L + 150}{2}$$

$$\Rightarrow 290 = L + 150$$

$$\Rightarrow L = 140$$

Also,

Fisher's index

$$= \sqrt{\text{Laspeyre's index} \times \text{Paasche's index}}$$

$$\Rightarrow \text{Fisher's index} = \sqrt{140 \times 150}$$

$$\Rightarrow \text{Fisher's index} = 144.91$$

27. (d) The simple Aggregative index is given by the formula,

$$\frac{\Sigma P_1}{\Sigma P_0} \times 100$$

$$= \frac{100 + 150 + 250 + 300}{80 + 100 + 120 + 200} \times 100$$

$$= \frac{800}{500} \times 100$$

$$= 160$$

28. (c) Let the salary of CA Jitendra in 2018 be x, then According to the question,

Year	Cost of living index	Income
2015	97.5	1,95,000
2018	115	x

Thus,

$$\frac{97.5}{115} = \frac{195000}{x}$$

$$\Rightarrow x = \frac{195000 \times 115}{97.5}$$

$$\Rightarrow x = 2,30,000$$

Therefore, the additional salary required

$$= 2,30,000 - 1,95,000$$

$$= 35,000$$

29. (b) Given: Prices of all the goods change in the same ratio

$$\text{Let } \frac{p_1}{p_0} = k \Rightarrow p_1 = kp_0$$

Therefore, Laspeyre's index

$$= \frac{\Sigma p_1 q_0}{\Sigma p_0 q_0} \times 100 = \frac{\Sigma k p_0 q_0}{\Sigma p_0 q_0} \times 100$$

$$= \frac{k \Sigma p_0 q_0}{\Sigma p_0 q_0} \times 100 = 100 k$$

Now, paasche's index

$$= \frac{\Sigma p_1 q_1}{\Sigma p_0 q_1} \times 100 = \frac{\Sigma k p_0 q_1}{\Sigma p_0 q_1} \times 100$$

$$= \frac{k \Sigma p_0 q_1}{\Sigma p_0 q_1} \times 100 = 100 k$$

Therefore, if the prices of all the goods change in the same ratio, then Laspeyre's index and Paasche's index number are equal.

30. (a) Weighted geometric mean satisfies Time Reversal test and Factor Reversal test is satisfied by Fisher's Ideal index.

31. (b) Let the equivalent salary in 2023 be x

$$\text{Therefore, } \frac{100}{15,000} = \frac{155}{x}$$

$$x = \frac{15000 \times 155}{100} = ₹23,250$$

Hence, Dearness Allowance (DA) is given by

$$\text{DA} = ₹23,250 - ₹15,000 = ₹8,250$$

32. (a) Given:

CPI in 2013 = 135

CPI in 2023 = 180

Salary in 2013 = ₹23,000

Salary in 2023 = ₹29,500

Let required salary in 2023 to maintain standard of living = x

$$x = \frac{23,000 \times 180}{135} = ₹30,666.66$$

$$\text{Additional amount} = ₹30,666.66 - ₹29,500$$

$$= ₹1,166.66 \approx ₹1,168$$



Chapter Wrap-up Test

Ready to test your knowledge?

You've got 15 questions and 20 minutes - Go for it!

1. Let p_0 and p_1 be the prices of a commodity in the base and current year respectively. The price relative with respect to base year is

(a) $\frac{p_1}{p_0}$ (b) $\frac{p_0}{p_1}$
 (c) $\frac{p_1 - p_0}{p_0}$ (d) $\frac{p_1 - p_0}{p_1}$

2. The number of test of Adequacy is

(a) 2 (b) 5
 (c) 3 (d) 4

3. Which of the following is not a test of adequacy in the context of index numbers?

- (a) Unit test
 (b) Square test
 (c) Circular test
 (d) Factor reversal test

4. Circular test is satisfied by which of the following index?

- (a) Laspeyre's index
 (b) Paasche's index
 (c) Fisher's index
 (d) Simple geometric mean of price relatives

5. The test of shifting the base is called

- (a) Unit test
 (b) Time Reversal test
 (c) Factor Reversal test
 (d) Circular test

6. P_{10} is the index for time.

- (a) 1 on 0 (b) 0 on 1
 (c) 1 on 1 (d) 0 on 0

7. Fisher index number is _____ of Laspeyres and Paasche's Index Number.

- (a) A.M (b) G.M
 (c) H.M (d) None of these

8. Which index measures the change from month to month in the cost of a representative basket of goods and services of the type bought by a typical household?

- (a) Retail Price Index
 (b) Laspeyre's Index
 (c) Fisher's index
 (d) Paasche's Index

9. In price index, when a new commodity is required to be added, which of the following index is used?

- (a) Shifted price index
 (b) Splicing price index
 (c) Deflating price index
 (d) Value price index

10. The cost of living is always

- (a) Price index number
 (b) Quantity index number
 (c) Weighted index number
 (d) Value index number

11. If $\sum P_0 Q_0 = 3500$, $\sum P_n Q_0 = 3850$, then the Cost of living Index (C.L.I) for 1950 with respect to base 1960 is

- (a) 110 (b) 90
 (c) 100 (d) None of these

12. In the year 2010 the monthly salary was ₹24,000. The consumer price index number was 140 in the year 2010 which rises to 224 in the year 2016. If he has to be rightly compensated then what additional monthly salary to be paid to him?

- (a) ₹14,400 (b) ₹38,400
 (c) ₹7,200 (d) None of these

13. If $\sum p_1q_1 = 249$, $\sum p_0q_0 = 150$, Paasche's Index Number = 150 and Dorbish and Bowely's Index number 145, then the Fisher's Ideal Index Number is

- (a) 175 (b) 144.91 (c) 145.97 (d) None

14. The weighted aggregative price index numbers for 2001 with 2000 as the base year using Laspeyre's Index Number is

Commodity	Price (in Rs.)		Quantities	
	2000	2001	2000	2001
A	12	14	10	20
B	10	8	20	30
C	8	10	30	10

- (a) 105 (b) 106.75 (c) 107.14 (d) 109.45

15. From the following data :

	Commodity	A	B	C	D
1992 Base Year	Price	3	5	4	3
	Quantity	18	6	20	14
1993 Current Year	Price	4	5	6	3
	Quantity	15	9	26	15

The Paasche's price index number is :

- (a) 146.41 (b) 148.25 (c) 144.25 (d) None

ANSWER KEY

1. (a) 2. (d) 3. (b) 4. (d) 5. (d) 6. (b) 7. (b) 8. (a) 9. (b) 10. (c)
 11. (a) 12. (a) 13. (b) 14. (c) 15. (a)



Mock Test Paper Series-I

Paper 3: Quantitative Aptitude

All Questions are Compulsory

Time: 2 Hours

Maximum Marks: 100

QUESTIONS

- Let $B = \{p, q, r, s, t, u\}$. How many proper subsets can be formed from set B ?
(a) 64 (b) 63
(c) 25 (d) 15
- If ${}^{15}C_{3m} = {}^{15}C_{(m+3)}$, then the value of 'm' is
(a) 2 (b) 3
(c) 5 (d) 7
- Find the geometric mean of the numbers: 30, 7, 28, 24, 15, 0, 11, 3.
(a) 36 (b) 20
(c) 8 (d) 0
- What is the 9th term of the arithmetic sequence? 8, 5, 2, -1, -4,....
(a) -20 (b) -16
(c) -8 (d) 2
- Find the value of k for which the given equation is true?
 $(\sqrt{4})^{-3} \times (2\sqrt{2})^{-8} = (\sqrt{2})^{-k}$
(a) 10 (b) 20
(c) 30 (d) 50
- Suppose x and y are linearly related through the equation $4x + 2y + 12 = 0$. If the mean deviation of x is given as 4.5, what would be the mean deviation of y ?
(a) 12 (b) 10
(c) 9 (d) 6
- If the standard deviation of a symmetrical distribution which consists of 100 items is 35, then the mean deviation of the distribution is
(a) 23.33 (b) 28
(c) 30 (d) 35
- If the roots of the equation $x^2 - 8x + 12 = 0$ are α & β , then the value of $\frac{\alpha + \beta}{\alpha\beta}$ is
(a) $\frac{1}{2}$ (b) $\frac{3}{2}$
(c) $\frac{2}{3}$ (d) $\frac{1}{4}$
- In a statistical table, which element is typically placed at the bottom to offer extra explanations or clarifications about the data?
(a) Footnotes (b) Stub
(c) Box-head (d) Caption
- If $\frac{x+3}{y+1} = 1$ and $\frac{x-2}{y-1} = \frac{1}{2}$, then the value of $\frac{x}{y}$ is
(a) $\frac{1}{7}$ (b) $\frac{5}{7}$
(c) $\frac{2}{3}$ (d) None
- For a random variable which follows Binomial distribution, the mean and the variance are 7 and 6 respectively, then the probability of failure is
(a) $\frac{2}{3}$ (b) $\frac{1}{7}$
(c) $\frac{6}{7}$ (d) $\frac{1}{36}$
- Find the value of x if $\log_7 [\log_4 x] = 1$.
(a) 28 (b) 2401
(c) 16,384 (d) None of the above
- Find the 6th decile for the following ordered data set: 8, 10, 12, 15, 18, 20, 21, 25
(a) 10 (b) 15.5
(c) 16.4 (d) 18.8

14. The difference between compound interest and simple interest on an amount of ₹10,000 for 2 years is ₹64. What is the rate of interest per annum?

- (a) 8% (b) 10%
(c) 16% (d) 20%

15. $\int_0^1 x^2 \cdot e^x dx$

- (a) $2e - 2$ (b) $e + 2$
(c) $e - 2$ (d) None of these

16. Let Y be the dependent variable and X be the independent variable. If the standard deviations of X and Y are 5 and 8 respectively, and the correlation coefficient between them is 0.8, what is the regression coefficient of Y on X ?

- (a) 0.75 (b) 0.98
(c) 1.28 (d) 1.5

17. Find the effective rate of interest if an amount of Rs. 30,000 deposited in a bank for 1 year at the rate of 10% compounded semi-annually.

- (a) 10% (b) 10.25%
(c) 10.65% (d) 11%

18. Five individuals are seated around a circular table. If the tallest person must always sit to the right of the shortest person, how many such arrangements are possible?

- (a) 3 (b) 6
(c) 16 (d) 25

19. If the population of a city three years ago was 40,960 and its present population is 49,130, then the rate of growth of population is

- (a) 6% (b) 6.25%
(c) 7.12% (d) 8%

20. If the square of a number exceeds twice of the number by 15, then the cube of the number is equal to

- (a) 5 (b) 25
(c) 125 (d) 150

21. The shareholding distribution of XYZ Ltd. is shown in the table below:

Share holders	Promo-tors	FII	MF	Others	Public
No. of shares in millions	120	25	20	20	15

If the data is represented as a pie chart, what is the difference between the central angles of FII and MF?

- (a) 15° (b) 9°
(c) 24° (d) 36°

22. A fertilizer manufacturer produces two categories of fertilizers, named Type A and Type B. Both types require processing in two essential chemical plant units. The plant operates for a maximum of 180 hours per week. Producing one bag of Type A fertilizer takes 3 hours in the plant, while producing one bag of Type B fertilizer takes 10 hours. The time constraint can be expressed as the inequality:

- (a) $3x_1 + 10x_2 > 180$ (b) $3x_1 + 10x_2 \leq 180$
(c) $x_1 + x_2 \leq 180$ (d) $5x_1 + 2x_2 \geq 180$

23. The equation of the tangent to the curve $x^2 + 3y = 3$ at the point $(-6, -11)$ is

- (a) $x + y = 13$ (b) $y + 4x = 13$
(c) $2x + 3y = 30$ (d) $y - 4x = 13$

24. The harmonic mean of the data: 2, 7, 12, 4, 19 is

- (a) 3.5 (b) 4.86
(c) 5.28 (d) None of these

25. If A is to the East of B , C is to the South of B and D is to the West of C , then A is in which direction with respect to D ?

- (a) South-West (b) North-East
(c) North-West (d) East

26. $\lim_{n \rightarrow 2} \frac{n^2 + 9 - 6n}{n - 3} =$

- (a) 1 (b) -1
(c) 3 (d) 5

27. Consider a relation R defined on the set $A = \{1, 2, 3, 4\}$ as follows:

$R = \{(1, 2), (2, 2), (1, 1), (4, 4), (1, 3), (3, 3), (3, 2)\}$, then the relation is;

- (a) R is an equivalence relation.
(b) R is symmetric, transitive but not reflexive.
(c) R is reflexive, symmetric but not transitive.
(d) R is reflexive, transitive but not symmetric.

28. The simple interest earned on a certain amount at 6% per annum over 7 years is twice the simple interest earned on another amount over 9 years at 5% per annum. What is the ratio of the two principal amounts?
- (a) 15 : 7 (b) 1 : 7
(c) 5 : 7 (d) 7 : 19
29. Calculate the compound interest on ₹15,625 for a period of 9 months at an annual interest rate of 16%, compounded quarterly.
- (a) ₹1800 (b) ₹1951
(c) ₹2064 (d) ₹2278
30. In a quiz competition, 12 school teams are participating. In how many different ways can the top three positions (first, second, and third) be awarded to these teams?
- (a) 1140 (b) 1275
(c) 1320 (d) 1575
31. Rohit invest Rs 10,000 every month in his account paying interest 12% per year compounded monthly. What is the future value of this annuity just after he makes 11th payment? (Given that $(1.01)^{11} = 1.1156$)
- (a) Rs 15,600 (b) Rs 75,890
(c) Rs 1,15,600 (d) None of these
32. In a particular code language:
- '493' stands for "Friendship difficult challenge",
 - '961' stands for "Struggle difficult Exam",
 - '178' stands for "Exam believable subject".
- Based on this information, which digit represents the word "believable"?
- (a) 1 or 8 (b) 7
(c) 8 (d) 7 or 8
33. The total of the initial eight terms in a geometric sequence is equal to five times the total of its first four terms. Determine the value of square of the common ratio.
- (a) 2 (b) $\sqrt{2}$
(c) 4 (d) $\sqrt{3}$
34. In a G.P., if $t_6 = 729$ and $r = 3$, then $a = ?$
- (a) 6 (b) 4
(c) 3 (d) 1
35. If the number of permutations of 2 items chosen from n distinct items is 72, then what is the value of n ?
- (a) 9 (b) 24
(c) 16 (d) 32
36. If $2 \log \left(\frac{x+y}{4} \right) = \log (xy)$, then the value of $x^2 + y^2$ is
- (a) $2xy$ (b) $12xy$
(c) $14xy$ (d) $16xy$
37. Find the odd man out of the following series; 7, 23, 47, 119, 167, 289
- (a) 47 (b) 23
(c) 167 (d) 289
38. The value of $f(3)$ such that the below function is continuous at $x = 3$ is
- $$f(x) = \frac{x^2 - 9}{x - 3}$$
- (a) 3 (b) 6
(c) 8 (d) 9
39. If the prices of all consumed commodities change in the same proportion, then what can be said about the Laspeyres' index and Paasche's index?
- (a) Reciprocal of Marshall Edgeworth's Index number
(b) Reciprocal of Fisher's Index number
(c) Unequal
(d) Equal
40. The minima of the function $y = 2x^3 - 15x^2 + 36x + 10$ occurs at
- (a) $x = -3$ (b) $x = 1$
(c) $x = 2$ (d) $x = 3$
41. An opportunity to purchase a machine for ₹70,000 has arisen. The machine is expected to generate ₹15,000 per year for the next four years with a borrowing cost of 8% per annum, should the machine be purchased or not?
- (a) Should be purchased
(b) Should not be purchased
(c) Can't say about purchase
(d) None of the above

42. Which type of data is best suited for display using a pie chart?

- (a) Data grouped into named categories
- (b) Data measured on a continuous scale
- (c) Ordinal data
- (d) Interval data

43. For a group of 6 students, the sum of squares of difference in ranks for Mathematics and Statistics marks are 44, then the value of rank correlation coefficient is

- (a) -0.15
- (b) -0.26
- (c) 0.69
- (d) None

44. Seven friends O, P, Q, R, S, T and U are watching movie sitting in a row. S is sitting at one extreme end. Q is sitting second to the right of S . P is sitting between O and Q . Both U and O are not sitting at extreme end. R is sitting immediate left to T . Who are sitting at the extremes?

- (a) S & P
- (b) S & T
- (c) S & U
- (d) S & R

45. The Earnings Per Share (EPS) of a company over a period of five years is shown in the table below:

Year	2019	2020	2021	2022	2023
EPS	40	25	45	75	90

Calculate the Compound Annual Growth Rate (CAGR) of the EPS during this period.

- (a) 16.44%
- (b) 22.47%
- (c) 25.95%
- (d) 30.55%

46. Kamal walks 10 km North, from there he walks 6 km towards South. Then he walks 3 km towards East. How far and in which direction is he with reference to starting point?

- (a) 5 km North-East
- (b) 5 km North-West
- (c) 7 km North-East
- (d) 5 km South-East

47. An exam paper contains 10 questions, out of which 6 are from Algebra and 4 are from Geometry. A student must attempt at least one question from each subject.

In how many different ways can the student choose one or more questions, ensuring that both subjects are represented?

- (a) 730
- (b) 872
- (c) 945
- (d) 1124

48. A perpetuity pays ₹625 annually, and the required rate of return is 8%. If the cash flow increases at a steady rate of 4% per year, what is the intrinsic value (present value) of this growing perpetuity?

- (a) ₹18,590
- (b) ₹16,000
- (c) ₹15,625
- (d) ₹11,765

49. What is the standard deviation of the first 20 natural numbers?

- (a) 4.65
- (b) 5.77
- (c) 6.35
- (d) 7.50

50. Ankita is facing the East direction. She turns 120° in the clockwise direction and then turns 180° in the anticlockwise direction. Which direction is she facing now?

- (a) East
- (b) West
- (c) North-East
- (d) South-East

51. Pointing to a photograph, Rajesh said, "The boy in the picture is Aarav. He is the son of the only daughter of the father of my brother", What is Rajesh's relationship to Aarav?

- (a) Brother
- (b) Maternal uncle
- (c) Father
- (d) Son-in-law

52. In a particular code language, the word PEAR is represented as 7519, and TOIL is written as 2693. Using the same coding pattern, what would be the code for DOCTOR?

- (a) 463269
- (b) 463296
- (c) 463293
- (d) 463399

53. Five girls A, B, C, D and E are sitting on a bench such that A is sitting next to B , C is sitting next to D , E is not sitting with D , E is at the left end of bench and C is on the 4th position from the left. If A is sitting to the right of B who is to the right side of E and A and C are sitting together, then the position of B is

- (a) Centre
- (b) Second from right
- (c) Second from left
- (d) Extreme left

54. Given the following relationships:

- X is the mother of Y .
- B is the daughter of Y .
- Z is the son of X .
- A is the brother of B .

Who is A 's grandmother?

- (a) X
- (b) Y
- (c) Z
- (d) B

55. Simplify; $\left(\frac{3^{2n+\frac{1}{2}} \cdot \sqrt{3^{n+1}}}{\sqrt{9 \cdot 3^{-n}}} \right)^{\frac{1}{n}}$
- (a) 9 (b) 27
(c) 81 (d) None of these

56. A coin with probability for head as $\frac{1}{5}$ is tossed 100 times, then the standard deviation of the number of heads turned up is

- (a) 3 (b) 4
(c) 7 (d) 10

57. Ana is facing north direction. She turns 90° in the clockwise direction, Again after a while she turns 180° in the anticlockwise direction and then another 90° in the same direction. Which direction is she facing now?

- (a) East (b) West
(c) North (d) South

58. In a specific coding scheme, the word STATEMENT is written as TNEMETATS. Following the same logic, how would the word GOVERNMENT be written in that code?

- (a) TNEMNREGOV (b) GOVMENREN
(c) TNEMNREVOG (d) None of these

59. The following table shows the number of books read by students in a library over a week. What is the coefficient of range?

Number of books read	1-5	6-10	11-15	16-20	21-25	26-30
Number of students	8	12	15	10	6	4

- (a) 108.3% (b) 96.77%
(c) 79.4% (d) 16.7%

60. Identify the missing number in the following series; 2, 8, 26, 62, 122, ----, 338

- (a) 200 (b) 212
(c) 264 (d) 289

61. A and B start moving towards each other from two places 200 m apart. After walking 60 m, B turns left and goes 20 m then he turns right and goes 40 m. He then turns right again and comes

back to the road on which he had started walking. If A and B walk with the same speed, what is the distance between them now?

- (a) 80 m (b) 70 m
(c) 40 m (d) 60 m

62. There are five friends: A, B, C, D, and E are sitting in a row facing north. B is sitting second to the right of A. C is sitting at one of the ends of the row. D is sitting to the immediate left of B. E is sitting to the immediate right of B. Who is sitting to the immediate right of C?

- (a) A (b) E
(c) D (d) B

63. Given that the current population is 100,000 in 2023, and the population grows by 3% in 2024, 4% in 2025, and 5% in 2026, then what will be the population at the end of 2026?

- (a) 1,20,500 (b) 1,15,700
(c) 1,12,500 (d) 1,09,850

64. B is daughter of A. C is brother of B. C is the only son of D. C and E are married couple. F is the only son of E. Then how is F related to A?

- (a) Father (b) Grandson
(c) Brother (d) Uncle

65. Given that the arithmetic mean (AM) and harmonic mean (HM) of two positive numbers are 5 and 3.2 respectively, find the geometric mean (GM) of these two numbers.

- (a) 4.5 (b) 4
(c) 3.6 (d) 3

66. There are six members in a family who are planning for a family trip together namely A, B, C, D, E and F where A and C are married couple. B is the son of C but C is not the mother of B. E is the brother of C. D is the daughter of A. F is the brother of B. How many female members are there in the family?

- (a) 3 (b) 2
(c) 4 (d) 1

67. The relationship between x and y is given by the equation $3x - 4y = 12$ and the range of y is 9, then what is the range of x?

- (a) 6 (b) 8
(c) 10 (d) 12

68. Which sampling method is best suited for making sure that all key subgroups in a population are represented according to their actual proportions?
- (a) Stratified Sampling
(b) Multistage Sampling
(c) Systematic Sampling
(d) None of these
69. In a certain code:
 $A \# B$ means "A is the father of B"
 $A * B$ means "A is the brother of B"
 $A @ B$ means "A is the mother of B"
 Given the expression: $G @ T \# P$
 What can be concluded from this?
- (a) T is son of G (b) P is father of T
(c) G is mother of P (d) None of these
70. If AM and C.V of a random variable X are 10 & 80 respectively, then the variance of $\left(-15 + \frac{3X}{4}\right)$ is
- (a) 6 (b) 8
(c) 36 (d) 64
71. A machine depreciates by 10% of its value at the start of each year. If the original cost of the machine is ₹23,240 and it is sold for a scrap value of ₹9,000, estimate the number of years the machine was in use.
- (a) 10 (b) 9
(c) 8 (d) 6
72. In an arithmetic progression, the 15th term is 30.5 and the 21st term is 39.5. Determine the first term of the sequence.
- (a) 1.5 (b) 3.7
(c) 5.5 (d) 9.5
73. If a Poisson distribution is such that $3P(x = 2) = P(x = 3)$, then the standard deviation of the distribution is
- (a) 9 (b) 3
(c) $\sqrt{3}$ (d) 1
74. Find the present value of an ordinary annuity of 10 quarterly payments of ₹1000 each, the rate of interest being 8% p.a. compound quarterly.
- (a) ₹4275.00 (b) ₹8982.59
(c) ₹9275.98 (d) None of these
75. Eight boys P, Q, R, S, T, U, V and W are sitting on a bench facing towards North.
- (i) T is fourth to the left of P.
(ii) S is fourth to the right of W.
(iii) U and R are not sitting at the ends, but they are neighbours of T and Q respectively.
(iv) P is next to the right of W and but left of Q. Who is sitting in the third place from the right?
- (a) R (b) Q
(c) S (d) U
76. Two dice are tossed. The probability that the sum of dots on the faces that turn up is 8 is
- (a) $\frac{1}{36}$ (b) $\frac{5}{36}$
(c) $\frac{1}{18}$ (d) None of these
77. According to the empirical rule, if the data follows a normal (bell-shaped) distribution, then the highest frequency of values occurs near the _____ and the lowest frequencies occur towards the _____.
- (a) Middle, left end (b) Middle, ends
(c) Middle, right end (d) None
78. Laspeyre's price index is a type of weighted aggregate index that uses which of the following as weights?
- (a) quantity consumed in the current year
(b) quantity consumed in the base year
(c) value of items consumed in the base year
(d) None of these
79. The ratio of students in three classes is 2 : 3 : 5. On increasing the students in each class by 40, the ratio changes to 4 : 5 : 7 then originally number of students in the first class was
- (a) 20 (b) 40
(c) 100 (d) 200
80. The variance of two variables 'x' and 'y' are 16 and 25 and covariance between 'x' and 'y' is 18.5. Another two variables 'u' and 'v' are defined as $u = \frac{(x-2)}{3}$ and $v = \frac{(y-3)}{2}$, then coefficient of correlation between 'u' and 'v' is:
- (a) 0.715 (b) 0.825
(c) 0.925 (d) None of these

81. If $x^y \times y^x = 16$, then the value of $\frac{dy}{dx}$ at $(2, 2)$ is

- (a) -1 (b) 0
(c) 2 (d) -2

82. The value of K for the probability density function of a random variable X is represented as:

x	0	1	2	3	4	5	6
$p(x)$	$3K$	$5k$	$7K$	$9K$	$11K$	$13K$	$15K$

- (a) $\frac{1}{5}$ (b) $\frac{1}{35}$
(c) $\frac{1}{25}$ (d) None

83. If $\sum p_1q_0 = 451$, $\sum p_1q_1 = 476$, $\sum p_0q_0 = 396$ and $\sum p_0q_1 = 426$, then find the Fisher's ideal Index Number.

- (a) 121.30 (b) 111.74
(c) 113.88 (d) 112.80

84. A random variable X has the following density function; $f(x) = 6x(1-x)$, $0 \leq x \leq 1$, then the mean is

- (a) $\frac{1}{3}$ (b) $\frac{1}{2}$
(c) $\frac{1}{5}$ (d) $\frac{1}{12}$

85. Find the sum of the series $\frac{1}{3^2} + \frac{1}{2} + \frac{1}{3^4} + \frac{1}{2^3} + \frac{1}{3^6} + \dots$ up to infinity is

- (a) $\frac{19}{24}$ (b) $\frac{1}{25}$
(c) $\frac{13}{24}$ (d) $\frac{11}{40}$

86. The overall percentage of failure in a certain examination is 0.30. What is the probability that out of a group of 6 candidates at least 4 passed the examination?

- (a) 0.60 (b) 0.74
(c) 0.85 (d) 0.93

87. From a population of 1,000 individuals, a random sample of 100 people is selected. The sample has an average height of 170 cm and a standard deviation of 10 cm. What is the standard error of the mean for this sample?

- (a) 2 cm (b) 0.8 cm
(c) 1 cm (d) 1.5 cm

88. Assuming Anita invests ₹5,000 annually starting today for the next 10 years in a mutual fund, and the average annual return compounded yearly is 18%, what will be the future value of her investment?

- (a) ₹1,83,680 (b) ₹1,71,680
(c) ₹1,38,775 (d) ₹1,20,880

89. The following scores were recorded in a math test: 55, 64, 78, 57, 47, 73, 40, 60, 70, 45

If the class width is 5, how many class intervals are required to organize this data into a frequency distribution?

- (a) 5 (b) 6
(c) 7 (d) 8

90. If $r = 0.5$, $\sum xy = 120$, $\sigma_y = 8$, $\sum x^2 = 90$, where x and y are the deviations from mean, then the value of n is

- (a) 8 (b) 10
(c) 11 (d) 14

91. A city has two dentists A and B who are operating independently. If the probability of availability of dentist A is 0.7 and of dentist B is 0.5, then the probability that at least one dentist is available when needed is

- (a) 0.85 (b) 0.56
(c) 0.72 (d) 0.35

92. Find the mode of the following distribution:

Class	0-7	7-14	14-21	21-28	28-35	35-42
Frequency	12	16	19	25	19	16

- (a) 20.5 (b) 24.5
(c) 27.0 (d) None of these

93. For the lines of regression $4x = 3 + 2y$ & $2x = 5 + 3y$, find b_{xy} .

- (a) 0.5 (b) 0.75
(c) 0.87 (d) 0.95

94. • B is the daughter of A .

- C is B 's brother.
- D has only one son, and that is C .
- C is married to E .
- E has only one son, named F .

How is F related to A ?

- (a) Son (b) Father
(c) Cousin (d) Grandson

95. The probability of a man hitting a target is $\frac{1}{4}$. If he fires 7 times, then the probability of his hitting the target at least once is

- (a) 0.555 (b) 0.768
(c) 0.866 (d) None

96. If $\Sigma P_0Q_0 = 3500$, $\Sigma P_nQ_0 = 3850$, then what is the Cost of Living Index (CLI) for the year 1950, using 1960 as the base year?

- (a) 60 (b) 90
(c) 10 (d) 110

97. The average of three numbers is 135. One of the numbers is the largest, and it is 180. The difference between the other two numbers is 25. What is the smallest of the three numbers?

- (a) 70 (b) 100
(c) 125 (d) 150

98. For the two series X and Y ;

$$\bar{X} = 90, \bar{Y} = 70, N = 10, \Sigma x^2 = 2860, \Sigma xy = 3900$$

The regression equation of X on Y is given by

- (a) $X = 0.613Y + 14.83$
(b) $X = 0.363Y + 5.41$
(c) $X = 1.363Y - 95.41$
(d) $X = 1.363Y - 5.41$

99. From the following data, construct the index number by Laspeyre's method;

$$\Sigma p_1q_1 = 99, \Sigma p_0q_1 = 76,$$

$$\Sigma p_0q_0 = 73, \Sigma p_1q_0 = 96$$

- (a) 131.51 (b) 130.88
(c) 136.25 (d) 139.25

100. The arithmetic mean for the following data is:

Marks	0-10	10-20	20-30	30-40	40-50
Number of students	20	24	40	36	20

- (a) 140
(b) 3620
(c) 25.85
(d) None of these

ANSWER KEY

1. (b) 2. (b) 3. (d) 4. (b) 5. (c) 6. (c) 7. (b) 8. (c) 9. (a) 10. (b)
11. (c) 12. (c) 13. (d) 14. (a) 15. (c) 16. (c) 17. (b) 18. (b) 19. (b) 20. (c)
21. (b) 22. (b) 23. (d) 24. (b) 25. (b) 26. (b) 27. (d) 28. (a) 29. (b) 30. (c)
31. (c) 32. (d) 33. (a) 34. (c) 35. (a) 36. (c) 37. (d) 38. (b) 39. (d) 40. (d)
41. (b) 42. (a) 43. (b) 44. (b) 45. (b) 46. (a) 47. (c) 48. (c) 49. (b) 50. (c)
51. (b) 52. (a) 53. (c) 54. (a) 55. (b) 56. (b) 57. (d) 58. (c) 59. (b) 60. (b)
61. (c) 62. (a) 63. (c) 64. (b) 65. (b) 66. (b) 67. (d) 68. (a) 69. (a) 70. (c)
71. (b) 72. (d) 73. (b) 74. (b) 75. (b) 76. (b) 77. (b) 78. (b) 79. (b) 80. (c)
81. (a) 82. (b) 83. (d) 84. (b) 85. (a) 86. (b) 87. (c) 88. (c) 89. (d) 90. (b)
91. (a) 92. (b) 93. (a) 94. (d) 95. (c) 96. (d) 97. (b) 98. (d) 99. (a) 100. (c)

HINTS & SOLUTIONS

1. (b) Given; $B = \{p, q, r, s, t, u\}$

Here, number of elements in set B, $(n) = 6$

Therefore, the number of proper subsets is given by

$$\begin{aligned} 2^n - 1 \\ &= 2^6 - 1 \\ &= 64 - 1 \\ &= 63 \end{aligned}$$

2. (b) Given; ${}^{15}C_{3m} = {}^{15}C_{m+3}$

$${}^nC_x = {}^nC_y$$

$$\Rightarrow n = x + y \text{ or } x = y$$

$$\Rightarrow 15 = 3m + m + 3$$

$$\Rightarrow 4m = 12$$

$$\Rightarrow m = 3$$

or

$$3m = m + 3$$

$$\Rightarrow 2m = 3$$

$$\Rightarrow m = \frac{3}{2} \text{ (reject)}$$

Since, m cannot be in fraction.

Therefore, the value of m is 3.

3. (d) We know,

Geometric Mean is given by

$$\begin{aligned} & (a_1 \times a_2 \times \dots \times a_n)^{\frac{1}{n}} \\ &= (30 \times 7 \times 28 \times 15 \times 0 \times 24 \times 11 \times 3)^{\frac{1}{8}} \\ &= (0)^{\frac{1}{8}} = 0 \end{aligned}$$

4. (b) Given sequence; 8, 5, 2, -1, -4,

Here, $a = 8, d = 5 - 8 = -3$

Thus, 9 th term is given by

$$t_9 = a + (9 - 1)d$$

$$t_9 = 8 + 8(-3)$$

$$t_9 = 8 - 24$$

$$t_9 = -16$$

5. (c) Given, $(\sqrt{4})^{-3} \times (2\sqrt{2})^{-8} = (\sqrt{2})^{-k}$

$$\Rightarrow (2)^{-3} \times (2)^{-8} \times (\sqrt{2})^{-8} = (\sqrt{2})^{-k}$$

$$\Rightarrow (2)^{-3+(-8)} \times (\sqrt{2})^{-8} = (\sqrt{2})^{-k}$$

$$\Rightarrow (2)^{-11} \times (\sqrt{2})^{-8} = (\sqrt{2})^{-k}$$

$$\Rightarrow (\sqrt{2})^{-22} \times (\sqrt{2})^{-8} = (\sqrt{2})^{-k}$$

$$\Rightarrow (\sqrt{2})^{-22+(-8)} = (\sqrt{2})^{-k}$$

$$\Rightarrow (\sqrt{2})^{-30} = (\sqrt{2})^{-k}$$

Thus, on comparing the powers, we get

$$k = 30$$

6. (c) Given; x and y are related as $4x + 2y + 12 = 0$

$$\Rightarrow 2y = -4x - 12$$

$$\Rightarrow y = -2x - 6$$

We know,

Mean deviation remains unchanged due to change in origin but changes in same ratio due to a change in scale.

Therefore, mean deviation of y is given by;

$$M \cdot D_y = |-2| \times M \cdot D_x$$

$$\Rightarrow M \cdot D_y = 2 \times 4.5 \Rightarrow M \cdot D_y = 9$$

7. (b) We know that,

Relation between Mean deviation and Standard deviation is given by:

$$M. D. = \frac{4}{5} \sigma$$

$$\Rightarrow M. D. = \frac{4}{5} \times 35$$

$$\Rightarrow M. D. = 4 \times 7$$

$$\Rightarrow M. D. = 28$$

Therefore, the required mean deviation is 28.

8. (c) Given equation; $x^2 - 8x + 12 = 0$

Since, α & β are the roots of the given equation, then

$$\alpha + \beta = -\frac{(-8)}{1} = 8$$

$$\alpha\beta = \frac{12}{1} = 12$$

Therefore,

$$\begin{aligned} & \frac{\alpha + \beta}{\alpha\beta} \\ &= \frac{8}{12} = \frac{2}{3} \end{aligned}$$

9. (a) We know that,

Footnotes are shown at the bottom part of a statistical table to provide additional information or clarity about certain aspects of the data presented in the table. They are used to explain the source of the data, define terms or abbreviations used in the table, highlight any specific conditions or exceptions, or provide any other relevant notes that enhance the understanding of the data. Footnotes help in avoiding confusion or ambiguity and provide important contextual details that cannot be included directly in the table itself.

10. (b) Given; $\frac{x+3}{y+1} = 1$ and $\frac{x-2}{y-1} = \frac{1}{2}$

$$\Rightarrow x + 3 = y + 1$$

$$\Rightarrow x - y = -2 \quad \dots(i)$$

Also, $\frac{x-2}{y-1} = \frac{1}{2}$

$$\Rightarrow 2(x-2) = y-1$$

$$\Rightarrow 2x - 4 = y - 1$$

$$\Rightarrow 2x - y = 3 \quad \dots(ii)$$

Subtracting eq (ii) from eq (i), we get

$$2x - y - (x - y) = 3 - (-2)$$

$$\Rightarrow 2x - y - x + y = 5$$

$$\Rightarrow x = 5$$

$$\Rightarrow y = x + 2 = 7$$

Therefore, $\frac{x}{y} = \frac{5}{7}$

11. (c) According to question, we have

$$np = 7$$

$$npq = 6$$

On dividing both the equation, we get $\frac{npq}{np} = \frac{6}{7}$

$$\Rightarrow q = \frac{6}{7}$$

12. (c) Given: $\log_7 [\log_4 x] = 1$

$$\Rightarrow \log_4 x = 7^1 = 7$$

$$\Rightarrow x = 4^7 = 16,384$$

Therefore, the value of x is 16,384.

Hence, the correct option is (c) i.e., 16,384.

13. (d) The given data is already in ascending order, i.e., 8, 10, 12, 15, 18, 20, 21, 25

Here, $n = 8$

Therefore, $D_6 = 6 \left[\frac{n+1}{10} \right]^{\text{th}}$ observation

$$= 6 \left[\frac{8+1}{10} \right]^{\text{th}} \text{ observation}$$

$$= (5.4)^{\text{th}} \text{ observation}$$

$$= 5^{\text{th}} + 0.4(6^{\text{th}} - 5^{\text{th}}) \text{ observations}$$

$$= 18 + 0.4(20 - 18)$$

$$= 18.8$$

14. (a) Given, Difference between compound interest and simple interest = ₹64

We know that, If P be the Principal and i be the rate of interest

$$C.I. - S.I. = Pi^2$$

$$\Rightarrow 64 = 10000 \times i^2$$

$$\Rightarrow i^2 = \frac{64}{10000}$$

$$\Rightarrow i^2 = 0.0064$$

$$\Rightarrow i^2 = (0.08)^2$$

$$\Rightarrow i = 0.08$$

i.e., $\frac{r}{100} = 0.08 = 8\%$

15. (c) To integrate; $\int_0^1 x^2 \cdot e^x dx$

Using 'ILATE' rule, here $u = x^2$ & $v = e^x$

$$= \left[x^2 \cdot \int e^x \right]_0^1 - \int_0^1 \left[\frac{d}{dx} (x^2) \cdot \int e^x \right] dx$$

$$= \left[x^2 \cdot e^x \right]_0^1 - \int_0^1 2x \cdot e^x dx$$

$$= \left[x^2 \cdot e^x \right]_0^1 - 2 \int_0^1 x \cdot e^x dx$$

$$= \left[x^2 \cdot e^x \right]_0^1 - 2 \left(\left[x \cdot e^x \right]_0^1 - \int_0^1 1 \cdot e^x dx \right)$$

$$= (1 \cdot e^1 - 0) - 2[(1 \cdot e^1 - 0) - [e^x]_0^1]$$

$$= e^1 - 2(e^1 - e^1 + e^0)$$

$$= e^1 - 2(1)$$

$$= e - 2$$

16. (c) According to the question, we have $\sigma_x = 5$, $\sigma_y = 8$ & $r = 0.8$

Therefore, the regression coefficient of Y on X is given by:

$$b_{yx} = r \frac{\sigma_y}{\sigma_x}$$

$$\Rightarrow b_{yx} = 0.8 \times \frac{8}{5}$$

$$\Rightarrow b_{yx} = 1.28$$

Hence, the regression coefficient of Y on X is 1.28.

17. (b) Given; Rate of interest (i) = 10%

Since, the interest is compounded semi - annually

Thus, the effective rate of interest is given by;

$$E = \left(\frac{10}{200} + 1 \right)^2 - 1$$

$$\Rightarrow E = 10.25\%$$

18. (b) Since, tallest person must always sit to the right of the shortest person thus assuming the tallest and shortest person as one.

Now, we have total 4 persons.

We know that,

Number of circular permutation of n different things chosen at a time = $(n - 1)!$

Therefore, the number of such arrangements is $(4 - 1)! = 3! = 6$.

19. (b) According to given information, we have

P = Population three years ago = 40,960

A = Present population = 49,130

$n = 3$ years

We know,

$$A = P \left(1 + \frac{r}{100} \right)^n$$

$$\Rightarrow 49130 = 40960 \left(1 + \frac{r}{100} \right)^3$$

$$\Rightarrow \frac{4913}{4096} = \left(1 + \frac{r}{100} \right)^3$$

$$\Rightarrow \left(\frac{17}{16} \right)^3 = \left(1 + \frac{r}{100} \right)^3$$

$$\Rightarrow \frac{17}{16} = 1 + \frac{r}{100}$$

$$\Rightarrow \frac{1}{16} = \frac{r}{100}$$

$$\Rightarrow r = \frac{100}{16} = 6.25$$

Therefore, the annual rate of growth is 6.25%.

20. (c) Let the number be x , where $x > 0$ then

$$x^2 = 2x + 15$$

$$\Rightarrow x^2 - 2x - 15 = 0$$

$$\Rightarrow x^2 - 5x + 3x - 15 = 0$$

$$\Rightarrow x(x - 5) + 3(x - 5) = 0$$

$$\Rightarrow (x + 3)(x - 5) = 0$$

$$\Rightarrow x = -3(\text{invalid}), x = 5$$

Therefore, the cube of the number

$$= x^3 = (5)^3 = 125.$$

21. (b) Given;

Share holders	Promotors	FII	MF	Others	Public
No. of shares in millions	120	25	20	20	16

Therefore, difference between the central angles of FII and MF is given by

$$\frac{25 - 20}{200} \times 360^\circ$$

$$= \frac{5}{200} \times 360^\circ$$

$$= 9^\circ$$

22. (b) Let the time required to manufacture one bag of grade I and grade II be ' x_1 ' & ' x_2 ' hours respectively.

Since, the plant has maximum of 180 hours available in a week, then

According to question, we have

$$3x_1 + 10x_2 \leq 180$$

23. (d) Given; $x^2 + 3y = 3$

Differentiating it with respect to x , we get

$$2x + 3 \frac{dy}{dx} = 0$$

$$\Rightarrow 3 \frac{dy}{dx} = -2x$$

$$\Rightarrow \frac{dy}{dx} = \frac{-2x}{3}$$

$$\Rightarrow \frac{dy}{dx} = \frac{-2(-6)}{3} = 4$$

Now, equation of tangent at point $(-6, -11)$ is given by;

$$\frac{y+11}{x+6} = 4$$

$$\Rightarrow y + 11 = 4(x + 6)$$

$$\Rightarrow y - 4x = 13$$

24. (b) Given data, 2, 7, 12, 4, 19

Therefore, the harmonic mean is given by

$$H.M = \frac{N}{\sum \left(\frac{1}{x} \right)}$$

$$\Rightarrow H.M = \frac{5}{\frac{1}{2} + \frac{1}{4} + \frac{1}{7} + \frac{1}{12} + \frac{1}{19}}$$

$$\Rightarrow H.M = \frac{5}{1.0288} = 4.86$$

25. (b) According to given information, we have

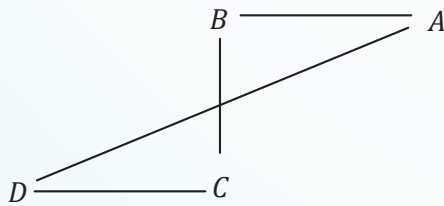

Therefore, A is in North - East direction with respect to D.

26. (b) $\lim_{n \rightarrow 2} \frac{n^2 + 9 - 6n}{n - 3}$

$$= \lim_{n \rightarrow 2} \frac{(n-3)^2}{n-3}$$

$$= \lim_{n \rightarrow 2} (n-3)$$

$$= 2 - 3$$

$$= -1$$

27. (d) Given set: $A = \{1, 2, 3, 4\}$

Relation $R = \{(1, 2), (2, 2), (1, 1), (4, 4), (1, 3), (3, 3), (3, 2)\}$

We know that,

For some set A,

Reflexive relation: If $(a, a) \in R$ for all $a \in A$

Symmetric relation: If $a, b \in A$ such that $(a, b) \in R$ then $(b, a) \in R$.

Transitive relation: If $a, b, c \in A$ such that $(a, b) \in R$ & $(b, c) \in R$ then $(a, c) \in R$. Here, $\forall 1, 2, 3, 4 \in A$, thus

$(1, 1), (2, 2), (3, 3), (4, 4) \in R$

Thus, the given relation is reflexive.

Now, $(1, 2) \in R$ but $(2, 1) \notin R$ thus it is not a symmetric relation.

Also, $(1, 3) \in R$ and $(3, 2) \in R$ then $(1, 2) \in R$ thus it is true for all the sets.

Therefore, the given set is reflexive, transitive but not a symmetric relation.

Hence, the correct option is (b).

28. (a) Let P_1 be the sum of money at 6% interest for 7 years, then

$$\text{Interest } (I_1) = \frac{P_1 \times 6 \times 7}{100}$$

$$\Rightarrow I_1 = \frac{42P_1}{100} \quad \dots(i)$$

Now, let P_2 be the sum of money at 5% interest for 9 years, then

$$\text{Interest } (I_2) = \frac{P_2 \times 5 \times 9}{100}$$

$$\Rightarrow I_2 = \frac{45P_2}{100} \quad \dots(ii)$$

According to the question,

$$I_1 = 2I_2$$

$$\Rightarrow \frac{42P_1}{100} = 2 \times \frac{45P_2}{100}$$

$$\Rightarrow \frac{P_1}{P_2} = \frac{2 \times 45}{42}$$

$$\Rightarrow \frac{P_1}{P_2} = \frac{15}{7}$$

Therefore, the required ratio is 15 : 7.

29. (b) According to question, we have

$$P = ₹15,625, t = 9 \text{ months} = \frac{9}{12} \text{ year}$$

$$\Rightarrow n = t \times m = 4 \times \frac{9}{12} = 3$$

& $r = 16\%$

We know that,

$$C.I. = P \left[\left(1 + \frac{r}{m} \right)^n - 1 \right]$$

$$\Rightarrow C.I. = 15625 \left[\left(1 + \frac{16}{400} \right)^3 - 1 \right]$$

$$\Rightarrow C.I. = 15625[(1.04)^3 - 1]$$

$$\Rightarrow C.I. = ₹1951$$

Therefore, the required interest is ₹1951.

- 30.** (c) Given: Total number of schools = 12

Since, order matters thus by using permutation
Total number of ways first, second and third position may be won

$$= {}^{12}P_3$$

$$= \frac{12!}{(12-3)!} \left(\because {}^n P_r = \frac{n!}{(n-r)!} \right)$$

$$= \frac{12!}{9!}$$

$$= \frac{12 \times 11 \times 10 \times 9!}{9!}$$

$$= 1320$$

- 31.** (c) Given: $A = \text{Rs } 10,000$, $n = 11$ and $i = 12\%$ per annum = 1% per month

We know that,

$$\text{Future value of an Annuity} = A \left[\frac{(1+i)^n - 1}{i} \right]$$

$$= 10000 \left[\frac{(1+0.01)^{11} - 1}{0.01} \right]$$

$$= 10000 \left[\frac{1.1156 - 1}{0.01} \right]$$

$$= 10000 \left[\frac{0.1156}{0.01} \right]$$

$$= 1,15,600$$

Therefore, the future value of an annuity is Rs 1,15,600.

- 32.** (d) Given; '493' means 'Friendship difficult challenge', '961' means 'Struggle difficult Exam'

Thus, the common code and number in above mentioned codes is Difficult and 9 respectively.

\Rightarrow Difficult $\rightarrow 9$

Now, '961' means 'Struggle difficult Exam' and '178' means 'Exam believable subject'

Thus, the common code and number in above mentioned codes is Exam and 1 respectively. \Rightarrow Exam $\rightarrow 1$

Thus, '178' means 'Exam believable subject' We cannot conclude the coded for believable & subject.

Hence, the code for believable can be either 7 or 8.

- 33.** (a) Given; Sum of first eight terms of geometric progression is five times the sum of the first four terms i.e.,

$$S_8 = 5 \times S_4$$

$$\Rightarrow \frac{a(r^8 - 1)}{r - 1} = 5 \times \frac{a(r^4 - 1)}{r - 1}$$

$$\Rightarrow (r^8 - 1) = 5(r^4 - 1)$$

$$\Rightarrow (r^4)^2 - 1^2 = 5(r^4 - 1)$$

$$\Rightarrow (r^4 - 1)(r^4 + 1) = 5(r^4 - 1)$$

$$\Rightarrow (r^4 + 1) = 5$$

$$\Rightarrow r^4 = 4 = (\sqrt{2})^4$$

$$\Rightarrow r = \sqrt{2}$$

$$\Rightarrow r^2 = 2$$

Therefore, the value of square of the common ratio is 2.

- 34.** (c) According to question, we have G.P series such that

$$t_6 = 729 \text{ \& } r = 3$$

$$\Rightarrow t_6 = ar^5$$

$$\Rightarrow 729 = a(3)^5$$

$$\Rightarrow a = \frac{729}{243}$$

$$\Rightarrow a = 3$$

Therefore, the first term of G.P is 3.

- 35.** (a) According to question, we have

$${}^n P_2 = 72$$

$$\Rightarrow \frac{n!}{(n-2)!} = 72$$

$$\Rightarrow \frac{n \times (n-1) \times (n-2)!}{(n-2)!} = 72$$

$$\Rightarrow n(n-1) = 9 \times 8$$

$$\Rightarrow n = 9$$

Therefore, the value of n is 9.

36. (c) Given, $2 \log \left(\frac{x+y}{4} \right) = \log (xy)$

$$\Rightarrow \log \left(\frac{x+y}{4} \right)^2 = \log (xy)$$

$$\Rightarrow \left(\frac{x+y}{4} \right)^2 = xy$$

$$\Rightarrow \frac{(x+y)^2}{4^2} = xy$$

$$\Rightarrow \frac{x^2 + 2xy + y^2}{16} = xy$$

$$\Rightarrow x^2 + y^2 + 2xy = 16xy$$

$$\Rightarrow x^2 + y^2 = 14xy$$

37. (d) Given series; 7, 23, 47, 119, 167, 289

On analysing the pattern, we get

$$3^2 - 2 = 7$$

$$5^2 - 2 = 23$$

$$7^2 - 2 = 47$$

$$11^2 - 2 = 119$$

$$13^2 - 2 = 169$$

$$17^2 - 2 = 287 \neq 289$$

Therefore, 289 is odd one out.

38. (b) Given; $f(x) = \frac{x^2 - 9}{x - 3}$

$$\Rightarrow \lim_{x \rightarrow 3} f(x) = \lim_{x \rightarrow 3} \frac{x^2 - 9}{x - 3}$$

$$\Rightarrow \lim_{x \rightarrow 3} f(x) = \lim_{x \rightarrow 3} \frac{(x-3)(x+3)}{x-3}$$

$$\Rightarrow \lim_{x \rightarrow 3} f(x) = \lim_{x \rightarrow 3} (x+3)$$

$$\Rightarrow \lim_{x \rightarrow 3} f(x) = 3 + 3 = 6$$

Therefore, the required value is 6.

39. (d) We know that,

When the prices for quantities consumed of all commodities are changing in the same ratio, then the index numbers due to Laspeyre's and Paasche's will be equal.

40. (d) Given; $y = 2x^3 - 15x^2 + 36x + 10$

On differentiating y wrt x , we get

$$\frac{dy}{dx} = 6x^2 - 30x + 36 \quad \dots (i)$$

$$\text{and } \frac{d^2y}{dx^2} = 12x - 30 \quad \dots(ii)$$

Now, substitute $\frac{dy}{dx} = 0$

$$\Rightarrow 6x^2 - 30x + 36 = 0$$

$$\Rightarrow x^2 - 5x + 6 = 0$$

$$\Rightarrow x^2 - 3x - 2x + 6 = 0$$

$$\Rightarrow x(x-3) - 2(x-3) = 0$$

$$\Rightarrow (x-3)(x-2) = 0$$

$$\Rightarrow x = 3 \text{ and } x = 2$$

Now, put $x = 3$ in (ii), we get

$$\frac{d^2y}{dx^2} = 36 - 30 = 6 > 0 \text{ attaining minima}$$

Now, put $x = 2$ in (ii), we get

$$\frac{d^2y}{dx^2} = 24 - 30 = -6 < 0, \text{ attaining maxima}$$

Therefore, the given function attains minima at $x = 3$.

41. (b) Given: Annuity amount (A) = ₹15,000

Number of installments (n) = 4

Rate of interest (i) = $8\% = \frac{8}{100} = 0.08$ p.a.

The present value is given by:

$$P(n, i) = A \left(\frac{1 - (1+i)^{-n}}{i} \right)$$

$$= 15000 \left(\frac{1 - (1+0.08)^{-4}}{0.08} \right)$$

$$= 15000 \left(\frac{1 - (1.08)^{-4}}{0.08} \right)$$

$$= 50,000 \text{ (approx)}$$

But it costs ₹70,000 which is more than its present value.

Thus, it should not be purchased.

Hence, the correct answer is option (b) i.e., should not be purchased.

42. (a) We know,

Pie charts are ideal for showing the proportions of different categories within a whole whereas Continuous, interval, and ordinal data are better represented with histograms, line charts, or box plots depending on the context.

43. (b) Given; $n = 6$ & $\sum d^2 = 44$

Therefore, the coefficient of rank correlation is given by:

$$R = 1 - \frac{\sum d^2}{n(n^2 - 1)}$$

$$= 1 - \frac{6 \times 44}{6 \times 35} = 1 - \frac{44}{35}$$

$$= -0.26 \text{ (approx)}$$

44. (b) According to question, we have
S is sitting at one extreme end i.e.,

S _ _ _ _ _

'or' _ _ _ _ _ S

Since, Q is sitting second to the right of S thus S cannot be at extreme right i.e.,

S _ Q _ _ _ _

Now, P is sitting between O and Q i.e.,

S _ Q P O _ _

Also, Both U and O are not sitting at extreme end & R is sitting immediate left to T.

Therefore, the final arrangement is;

S U Q P O R T

Hence, S and T are sitting at the extremes.

45. (b) According to data,

Year	2019	2020	2021	2022	2023
EPS	40	25	45	75	90

Therefore, CAGR can be calculated as;

$$\left[\left(\frac{90}{40} \right)^{\frac{1}{4}} - 1 \right] \times 100\%$$

$$= \left[(2.25)^{\frac{1}{4}} - 1 \right] \times 100\% = 22.47\%$$

46. (a) Following the directions as per the question, we get

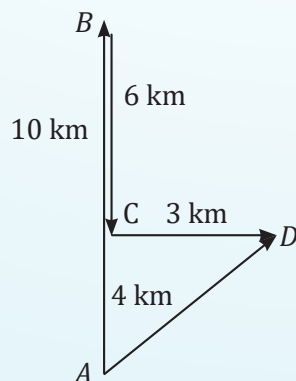

Therefore, the distance between the starting and ending point

$$= \sqrt{3^2 + 4^2} = \sqrt{9 + 16} = \sqrt{25} = 5 \text{ km.}$$

Hence, he is 5 km North - East with reference to starting point.

47. (c) Given;

Total questions = 10

Number of questions of Algebra = 6 & Number of questions of Geometry = 4

Since, At least one question from each section is to be attempted thus

Number of ways of attempting questions from Algebra is given by;

$$= {}^6C_1 + {}^6C_2 + {}^6C_3 + {}^6C_4 + {}^6C_5$$

$$= 2^6 - 1$$

$$= 63$$

Similarly, Number of ways of attempting questions from Geometry is given by;

$$2^4 - 1 = 15$$

Therefore, the total ways = $63 \times 15 = 945$.

48. (c) According to the question,

$$R = \text{Rs. } 625, i = 0.08 \text{ and } g = 0.04$$

Therefore, the intrinsic value (present value) of this growing perpetuity is given by;

$$PVA = \frac{R}{i - g}$$

$$= \frac{625}{0.08 - 0.04}$$

$$= \frac{625}{0.04}$$

$$= ₹15,625$$

49. (b) We know that,

Standard deviation of first n natural numbers is given by

$$S.D. = \sqrt{\frac{n^2 - 1}{12}}$$

Here, $n = 20$

$$\text{Therefore, } S.D = \sqrt{\frac{20^2 - 1}{12}} = \sqrt{\frac{199}{12}}$$

$$= 5.77 \text{ (approx)}$$

50. (c) According to given data, we have

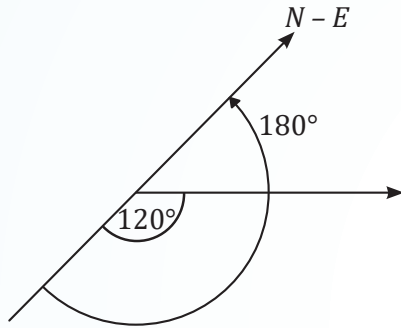

Therefore, she is facing North-East direction now.

51. (b) According to given condition, we have

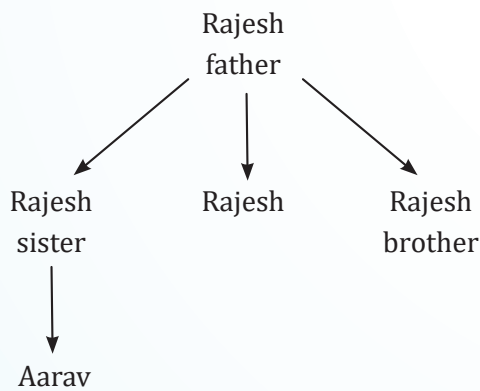

Since, Aarav is Rajesh's sister son.

Therefore, Rajesh is maternal uncle of Aarav.

52. (a) Given; *PEAR* is coded as 7519 and *TOIL* is coded as 2693

$$P \rightarrow 16 \rightarrow 1 + 6 = 7$$

$$E \rightarrow 5$$

$$A \rightarrow 1$$

$$R \rightarrow 18 \rightarrow 1 + 8 = 9$$

Similarly, the code for *TOIL*

$$T \rightarrow 20 \rightarrow 2 + 0 = 2$$

$$O \rightarrow 15 \rightarrow 1 + 5 = 6$$

$$I \rightarrow 9$$

$$L \rightarrow 12 \rightarrow 1 + 2 = 3$$

Therefore, the code for *DOCTOR* will be

$$D \rightarrow 4$$

$$O \rightarrow 15 \rightarrow 1 + 5 = 6$$

$$C \rightarrow 3$$

$$T \rightarrow 20 \rightarrow 2 + 0 = 2$$

$$O \rightarrow 15 \rightarrow 1 + 5 = 6$$

$$R \rightarrow 18 \rightarrow 1 + 8 = 9$$

Hence, the code for *DOCTOR* will be 463269.

53. (c) According to the question, we have

E B A C D

Therefore, *B* is at the second position of left.

54. (a) According to given data, we have'

- *X* is the mother of *Y*.
- *B* is the daughter of *Y*.
- *Z* is the son of *X*.
- *A* is the brother of *B*.

This can be represented as;

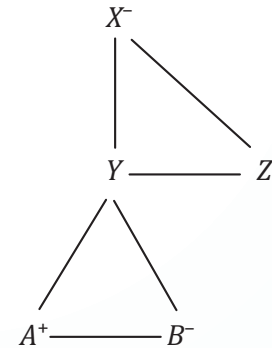

where, negative sign represents the person is a female and positive sign represents the person is male.

Therefore, *X* is *A*'s grandmother.

55. (b)

$$\begin{aligned} & \left(\frac{3^{2n+\frac{1}{2}} \cdot \sqrt{3^{n+1}}}{\sqrt{9 \cdot 3^{-n}}} \right)^{\frac{1}{n}} \\ &= \left(\frac{3^{2n+\frac{1}{2}} \cdot 3^{\frac{n+1}{2}}}{\sqrt{3^2 \cdot 3^{-n}}} \right)^{\frac{1}{n}} \\ &= \left(\frac{3^{2n+\frac{1}{2}+\frac{n}{2}+\frac{1}{2}}}{3^{\frac{2-n}{2}}} \right)^{\frac{1}{n}} \\ &= \left(3^{2n+\frac{1}{2}+\frac{n}{2}+\frac{1}{2}-1+\frac{n}{2}} \right)^{\frac{1}{n}} \\ &= (3^{2n+n+1-1})^{\frac{1}{n}} \\ &= (3^{3n})^{\frac{1}{n}} \\ &= 3^3 = 27 \end{aligned}$$

56. (b) According to question, we have

$$p = \frac{1}{5}$$

$$\Rightarrow q = 1 - \frac{1}{5} = \frac{4}{5}$$

Now, the standard deviation is given by;

$$\sqrt{npq}$$

$$= \sqrt{100 \times \frac{1}{5} \times \frac{4}{5}} = \sqrt{16} = 4$$

57. (d) The directions of Ana according to the question is as follow:

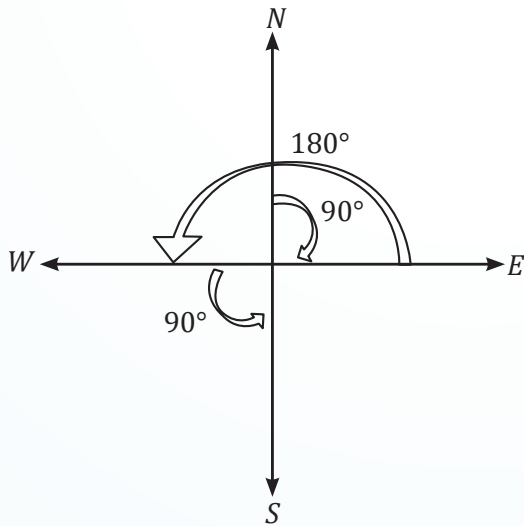

Therefore, Ana is facing the South direction now.
Hence, the correct option is (d) i.e., South.

58. (c) Given; STATEMENT is written as TNEMETATS

Observe the pattern:

STATEMENT \rightarrow TNEMETATS

Therefore, applying the same logic:

GOVERNMENT \rightarrow TNEMNREVOG

Therefore, the word GOVERNMENT be written in that code as TNEMNREVOG.

59. (b) For given distribution we will convert class intervals into a class boundaries by subtracting 0.5 from lower limit and adding 0.5 to upper limit.
Thus, Lowest class boundary (S) = 1 - 0.5 i.e., $S = 0.5$

Highest class boundary (L) = 30 + 0.5 i.e., $L = 30.5$

Since, coefficient of range = $\frac{L-S}{L+S} \times 100$

$$= \frac{30.5-0.5}{30.5+0.5} \times 100$$

$$= \frac{30}{31} \times 100 = 96.77\%$$

Therefore, option (b) is correct i.e. 96.77%.

60. (b) Given series; 2, 8, 26, 62, 122, _____, 338

On analysing the pattern, we get

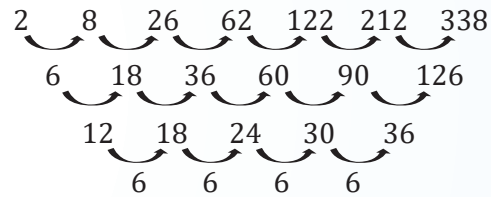

Therefore, the required number is 212.

61. (c) Distance traveled by A on road = 60 + 20 + 40 + 20 = 140 m

Distance traveled by B on road = 60 + 40 = 100 m

Required difference = 140 - 100 = 40 m

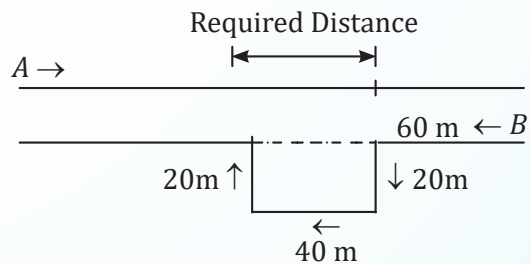

Hence, option (c) is correct i.e. 40 m.

62. (a) Since C is sitting at one of the ends of the row, there are only two possibilities: either C is sitting at the extreme left end, or C is sitting at the extreme right end.

Let's consider both cases:

Case 1: C is sitting at the extreme left end.

In this case, the order of the friends from left to right is: C, A, B, D, E.

Therefore, the friend sitting to the immediate right of C is A.

Case 2: C is sitting at the extreme right end.

In this case, the order of the friends from left to right is: A, B, D, E, C.

Therefore, the friend sitting to the immediate right of C is not mentioned in the given information.

Since we don't have enough information to determine who is sitting to the immediate right of C in the second case, the answer is A for the first case.

Hence, the correct option is (a) i.e., A.

63. (c) Given; Current population in 2023(P) = 1,00,000, $r_1 = 3%$, $r_2 = 4%$ & $r_3 = 5%$

Therefore, the population after 3 years will be given by;

$$\begin{aligned} P(1+r_1)^1(1+r_2)^1(1+r_3)^1 \\ = 100000(1+0.03)(1+0.04)(1+0.05) \\ = 1,12,476 \\ = 1,12,500 \text{ (approx)} \end{aligned}$$

Therefore, the required population is 1,12,500.

64. (d) Presenting the given relations in diagram, we get

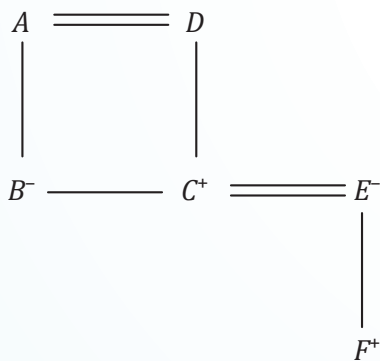

where,

- \rightarrow female, + \rightarrow Male, = \rightarrow Married

Therefore, F is grandon of A .

65. (b) We know that,

$$\begin{aligned} GM^2 &= AM \times HM \\ \Rightarrow GM^2 &= 5 \times 3.2 \\ \Rightarrow GM &= \sqrt{5 \times 3.2} \\ \Rightarrow GM &= 4.0 \end{aligned}$$

66. (b) According to the question,

Total members = 6

B is the son of C but C is not the mother of B

i.e., B is a male and C is a male too as C is the father of B .

Also, A and C are married couple

i.e., C is a male, thus A is a female.

Now, E is the brother of C thus E is a male.

D is the daughter of A i.e., D is a female.

F is the brother of B i.e., F is a male.

B, C, E, F are males and D, A are females.

Therefore, there are 2 females in the family.

67. (d) Given: $3x - 4y = 12$

$$\Rightarrow 3 \text{ Range } x = 4 \text{ Range } y$$

As, the range of $y = 9$

$$\text{Thus, } 3 \times \text{Range } (x) = 4 \times 9$$

$$\text{Range } (x) = \frac{36}{3} = 12$$

Therefore, the range of x is 12.

Hence, the correct option is (d) i.e., 12.

68. (a) We know,

Stratified Sampling technique is most appropriate when a person wants to ensure that subgroups are proportionally represented.

69. (a) Presenting $G @ T \# P$ in the diagram, we get

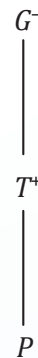

where, negative sign represent person is a female and positive sign represents person is a male. Therefore, from the above diagram we get T is son of G .

70. (c) We know that, Coefficient of variation (C.V)

$$= \frac{\sigma}{\bar{X}} \times 100$$

Given, $C.V. = 80$ and $\bar{X} = 10$

$$\text{then, } 80 = \frac{\sigma}{10} \times 100$$

$$\Rightarrow \sigma = 8$$

$$\text{Thus, } S.D \left(-15 + \frac{3X}{4} \right) = \frac{3}{4} \times SD(X)$$

$$= \frac{3}{4} \times 8$$

$$= 6$$

Therefore, Variance = $6^2 = 36$

71. (b) According to given data,

Depreciation Rate = 10%

Principal (Cost Value) = ₹23, 240

Amount (Scrap Value) = ₹9,000

$$\therefore i = \frac{\text{Rate of Depreciation}}{100} = \frac{10}{100} = 0.1$$

We know that,

$$\text{Net value} = \text{Initial value} \times (1 - i)^n$$

$$\Rightarrow 9000 = 23240(1 - 0.1)^n$$

$$\Rightarrow (0.9)^n = \frac{9000}{23240}$$

$$\Rightarrow (0.9)^n = 0.38726334$$

$$\Rightarrow n = \frac{\log(0.38726334)}{\log 0.9}$$

$$\Rightarrow n = 9$$

Therefore, the required time period is 9 years.

72. (d) According to question, we have

$$t_{15} = 30.5 \text{ \& } t_{21} = 39.5$$

$$\Rightarrow a + 14d = 30.5 \text{ \& } a + 20d = 39.5$$

On subtracting both the equations, we get

$$a + 20d - (a + 14d) = 39.5 - 30.5$$

$$\Rightarrow 20d - 14d = 9$$

$$\Rightarrow 6d = 9$$

$$\Rightarrow d = 1.5$$

Now,

$$a = 30.5 - 14d = 30.5 - 14(1.5) = 9.5.$$

Therefore, the value of first term is 9.5.

73. (b) Given; $3P(x = 2) = P(x = 3)$

$$\Rightarrow 3 \times \frac{e^{-m} \cdot m^2}{2} = \frac{e^{-m} \cdot m^3}{3 \times 2 \times 1}$$

$$\Rightarrow m = \frac{18}{2}$$

$$\Rightarrow m = 9$$

$$\Rightarrow \sqrt{m} = \sqrt{9}$$

$$\Rightarrow \sqrt{m} = 3$$

Therefore, the standard deviation is 3.

74. (b) Given;

$$A = ₹1000, r = 8\% \text{ p.a.}, n = 10, c = 4$$

$$\Rightarrow i = \frac{0.08}{4} = 0.02$$

We know that,

$$PV = \frac{A[(1+i)^n - 1]}{i(1+i)^n}$$

$$= \frac{1000[(1+0.02)^{10} - 1]}{0.02(1+0.02)^{10}}$$

$$= \frac{1000(1.21899442 - 1)}{0.02(1.21899442)}$$

$$= ₹8982.59 \text{ (approx)}$$

75. (b) Given;

(i) T is fourth to the left of P .

(ii) S is fourth to the right of W .

(iii) U and R are not sitting at the ends, but they are neighbours of T and Q respectively.

(iv) P is next to the right of W and but left of Q .

Therefore, the arrangement is:

$TUVWPQRS$

Hence, Q is sitting in the third place from the right.

76. (b) Given; Two dice are tossed

Thus, total outcomes = 36

Favourable outcomes: $\{(6, 2), (5, 3), (4, 4), (3, 5), (2, 6)\}$

Thus, number of favourable outcomes = 5

Therefore, the required probability = $\frac{5}{36}$.

77. (b) According to the empirical rule, if the data form a "bell - shaped" distribution, then the highest (maximum) and lowest (minimum) frequencies occur at middle and ends respectively.

78. (b) We know,

Laspeyre's Index uses base year quantities as weights while comparing current year prices to base year prices.

79. (b) Given; Ratio of students in three classes

$$= 2 : 3 : 5$$

According to question,

$$(2x + 40) : (3x + 40) : (5x + 40) = 4 : 5 : 7$$

$$\Rightarrow \frac{2x + 40}{3x + 40} = \frac{4}{5}$$

$$\Rightarrow 5(2x + 40) = 4(3x + 40)$$

$$\Rightarrow 10x + 200 = 12x + 160$$

$$\Rightarrow 2x = 40$$

$$\Rightarrow x = 20$$

Therefore, the number of students in the first class was $2(20) = 40$.

80. (c) We have,

$$\sigma_x^2 = 16, \sigma_y^2 = 25, \text{Cov}(x, y) = 18.5$$

$$\Rightarrow \sigma_x = 4, \sigma_y = 5$$

We know,

$$r_{xy} = \frac{\text{cov}(x, y)}{\sigma_x \cdot \sigma_y}$$

$$\Rightarrow r_{xy} = \frac{18.5}{4 \times 5} = 0.925$$

$$\Rightarrow r_{uv} = 0.925$$

81. (a) Given; $x^y \times y^x = 16$

Taking log on both sides, we get

$$\log(x^y \times y^x) = \log 16$$

$$y \log x + x \log y = \log 16$$

Differentiating wrt x, we get

$$y \cdot \frac{1}{x} + \log x \cdot \frac{dy}{dx} + x \cdot \frac{1}{y} \frac{dy}{dx} + \log y = 0$$

At (2, 2)

$$\Rightarrow \frac{2}{2} + \log 2 \cdot \frac{dy}{dx} + \frac{2}{2} \frac{dy}{dx} + \log 2 = 0$$

$$\Rightarrow 1 + \log 2 + \frac{dy}{dx} (\log 2 + 1) = 0$$

$$\Rightarrow (\log 2 + 1) \frac{dy}{dx} = - (1 + \log 2)$$

$$\Rightarrow \frac{dy}{dx} = -1$$

82. (b) We know that,

For a Probability Density Function, $\sum p(x) = 1$

Therefore,

$$3K + 5K + 7K + 9K + 11K + 13K$$

$$+ 15K = 1$$

$$\Rightarrow 63K = 1$$

$$\Rightarrow K = \frac{1}{63}$$

83. (d) Given,

$$\sum p_1 q_0 = 451, \sum p_1 q_1 = 476, \sum p_0 q_0$$

$$= 396 \text{ and } \sum p_0 q_1 = 426$$

We know that,

Fisher's ideal index

$$= \sqrt{\frac{\sum p_1 q_0}{\sum p_0 q_0} \times \frac{\sum p_1 q_1}{\sum p_0 q_1}} \times 100$$

$$= \sqrt{\frac{451}{396} \times \frac{476}{426}} \times 100$$

$$= \sqrt{1.1388 \times 1.1174} \times 100$$

$$= 112.80$$

84. (b) Mean = $\int_0^1 x \cdot f(x) dx$

$$= \int_0^1 x \cdot 6x(1-x) dx$$

$$= \int_0^1 6x^2(1-x) dx$$

$$= 6 \int_0^1 (x^2 - x^3) dx$$

$$= 6 \left[\frac{x^3}{3} - \frac{x^4}{4} \right]_0^1$$

$$= 6 \left[\left(\frac{1}{3} - 0 \right) - \left(\frac{1}{4} - 0 \right) \right]$$

$$= 6 \left(\frac{1}{3} - \frac{1}{4} \right)$$

$$= \frac{1}{2}$$

85. (a) Given;

$$S = \frac{1}{3^2} + \frac{1}{2} + \frac{1}{3^4} + \frac{1}{2^3} + \frac{1}{3^6} + \dots \infty$$

$$\Rightarrow S = \left[\frac{1}{2} + \frac{1}{2^3} + \frac{1}{2^5} + \dots \right]$$

$$+ \left[\frac{1}{3^2} + \frac{1}{3^4} + \frac{1}{3^6} + \dots \right]$$

$$\Rightarrow S = \frac{\frac{1}{2}}{1 - \frac{1}{2^2}} + \frac{\frac{1}{9}}{1 - \frac{1}{3^2}}$$

$$\Rightarrow S = \frac{\frac{1}{2}}{\frac{3}{4}} + \frac{\frac{1}{9}}{\frac{8}{9}}$$

$$\Rightarrow S = \frac{2}{3} + \frac{1}{8} \Rightarrow S = \frac{19}{24}$$

86. (b) According to question, we have

$$q = 0.3, p = 1 - 0.3 = 0.7 \text{ \& } n = 6$$

Therefore, the probability that out of a group of 6 candidates at least 4 passed the examination is given by;

$$\begin{aligned} P(x \geq 4) &= {}^6C_4 (0.7)^4 (0.3)^2 \\ &+ {}^6C_5 (0.7)^5 (0.3)^1 + {}^6C_6 (0.7)^6 (0.3)^0 \\ \Rightarrow P(x \geq 4) &= 0.324135 + 0.302526 + 0.117649 \\ \Rightarrow P(x \geq 4) &= 0.74(\text{approx}) \end{aligned}$$

87. (c) Given; $n = 100$, $N = 1000$, Mean = 170 & $\sigma = 10$

$$\text{Thus, } \frac{n}{N} = \frac{100}{1000} = 0.1$$

$$\text{Since, } \frac{n}{N} > 0.05$$

$$\text{Therefore, } S.E = \frac{\sigma}{\sqrt{n}} \sqrt{\frac{N-n}{N-1}}$$

$$\Rightarrow S.E = \frac{10}{\sqrt{100}} \sqrt{\frac{1000-100}{1000-1}}$$

$$\Rightarrow S.E = \frac{10}{10} \sqrt{\frac{990}{999}}$$

$$\Rightarrow S.E = 0.995 \approx 1.0 \text{ cm}$$

88. (c) Given;

$$R = ₹5000$$

$$t = 10 \text{ years}$$

$$\Rightarrow n = t \times m = 10 \times 1 = 10$$

$$i = 18\%$$

Since, the the annuity is starting from today, thus it is an Annuity Due/Immediate.

We know,

$$F.V = R \left\{ \frac{(1+i)^{n+1} - 1}{i} \right\} (1+i)$$

$$\Rightarrow F.V = 5000 \left\{ \frac{(1+0.18)^{10+1} - 1}{0.18} \right\} (1+0.18)$$

$$\Rightarrow F.V = 5000 \left\{ \frac{(1.18)^{11} - 1}{0.18} \right\} (1.18)$$

$$\Rightarrow F.V = 1,38,775 (\text{approx})$$

89. (d) Given dataset; 55, 64, 78, 57, 47, 73, 40, 60, 70, 45

We know,

$$\begin{aligned} \text{Number of classes} &= \frac{\text{Range}}{\text{Class width}} \\ &= \frac{78-40}{5} \\ &= \frac{38}{5} \\ &= 7.6 \approx 8 \end{aligned}$$

90. (b) Given; $r = 0.5$, $\sum xy = 120$,

$$\sigma_y = 8, \sum x^2 = 90$$

We know,

$$r = \frac{\sum (x_i - \bar{x})(y_i - \bar{y})}{\sqrt{\frac{\sum (x_i - \bar{x})^2}{n}} \cdot \sigma_y}$$

$$\Rightarrow 0.5 = \frac{120}{n} \times \sqrt{\frac{n}{90}} \times \frac{1}{8}$$

$$\Rightarrow 0.5 = \frac{120}{\sqrt{n}} \times \frac{1}{\sqrt{90}} \times \frac{1}{8}$$

$$\Rightarrow \sqrt{n} = \frac{0.5 \times \sqrt{90} \times 8}{120}$$

$$\Rightarrow n = 10$$

Therefore, the value of n is 10.

91. (a) Given; $P(A) = 0.7$ and $P(B) = 0.5$

Since, A and B are operating independently thus

$$P(A \cap B) = P(A) \cdot P(B)$$

$$\Rightarrow P(A \cap B) = 0.7 \times 0.5 = 0.35$$

Now, P (atleast one dentist is available) is given by;

$$P(A \cup B) = P(A) + P(B) - P(A \cap B)$$

$$\Rightarrow P(A \cup B) = 0.7 + 0.5 - 0.35$$

$$\Rightarrow P(A \cup B) = 0.85$$

92. (b) As we know, modal class is given by the highest frequency class, i.e., 21 - 28 in this case.

So, Modal class: 21 - 28

Mode is given by the formula,

$$\text{Mode} = l + \left[\frac{f_1 - f_0}{2f_1 - f_0 - f_2} \right] \times h$$

Where, $l \rightarrow$ Lower limit of modal class,
 $f_1 \rightarrow$ Frequency of modal class, $f_0 \rightarrow$ Frequency
preceding modal class, $f_2 \rightarrow$ Frequency
succeeding modal class, $h \rightarrow$ Class size

So put the respective values and compute,

$$\begin{aligned} \text{Mode} &= 21 + \left[\frac{25-19}{2(25)-19-19} \right] \times 7 \\ &= 21 + \left(\frac{6}{12} \right) \times 7 \\ &= 24.5 \end{aligned}$$

93. (a) Given; $4x = 3 + 2y$ & $2x = 5 + 3y$

Let $4x = 3 + 2y$ be the regression line of x on y ,
then

$$\begin{aligned} 4x &= 2y + 3 \\ \Rightarrow x &= \frac{1}{2}y + \frac{3}{4} \\ \Rightarrow b_{xy} &= \frac{1}{2} \end{aligned}$$

Now, let $2x = 5 + 3y$ be the regression line of y
on x , then

$$\begin{aligned} 3y &= 2x - 5 \\ \Rightarrow y &= \frac{2}{3}x - \frac{5}{3} \\ \Rightarrow b_{yx} &= \frac{2}{3} \end{aligned}$$

Now, $b_{xy} \cdot b_{yx} = \frac{1}{2} \times \frac{2}{3} = \frac{1}{3} < 1$ which hold the
condition.

Therefore, $b_{xy} = \frac{1}{2} = 0.5$.

94. (d) According to given relations, we have

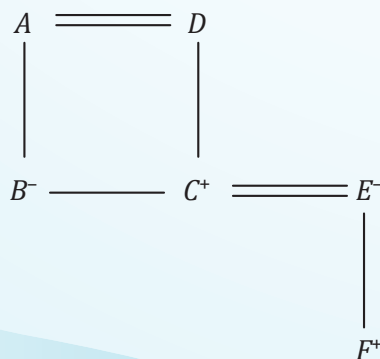

where, positive sign represents the person is
male and negative represents the person is a
female

Therefore, F is grandson of A .

95. (c) Given; Probability of a man hitting a target =
 $\frac{1}{4}$

Thus, Probability of a man not hitting a target

$$= 1 - \frac{1}{4} = \frac{3}{4}$$

Here, $n = 7$

Therefore, the probability of his hitting the
target at least once is given by;

$$\begin{aligned} P(X \geq 1) \\ \Rightarrow 1 - P(X = 0) \\ \Rightarrow 1 - {}^7C_0 \left(\frac{3}{4} \right)^7 \left(\frac{1}{4} \right)^0 \\ \Rightarrow 1 - \left(\frac{3}{4} \right)^7 \\ \Rightarrow 1 - \frac{2187}{16384} \\ \Rightarrow 0.866 \end{aligned}$$

96. (d) Given;

$$\Sigma P_o Q_o = 3500, \Sigma P_n Q_o = 3850$$

We know that, Cost of living Index,

$$C.I. = \frac{\text{Current year price}}{\text{Base year price}} \times 100$$

$$\Rightarrow C.I. = \frac{3850}{3500} \times 100$$

$$\Rightarrow C.I. = 110$$

97. (b) Let the three numbers be $a, b, 180$.

According to question,

$$\frac{a+b+180}{3} = 135$$

$$\Rightarrow a + b + 180 = 405$$

$$\Rightarrow a + b = 225 \quad \dots(i)$$

$$\text{Also, } b - a = 25 \quad \dots(ii)$$

From (i) and (ii), we get

$$2b = 250$$

$$\Rightarrow b = 125$$

$$\text{Thus, } a = 100$$

Hence, the smallest number is 100.

98. (d) Given;

$$\bar{X} = 90, \bar{Y} = 70, N = 10, \sum x^2 = 2860$$

$$\sum xy = 3900$$

Regression coefficient of X on Y;

$$b_{xy} = \frac{\sum xy}{\sum y^2} = \frac{3900}{2860} = 1.363$$

Therefore, Regression equation of X on Y is given as:

$$X - \bar{X} = b_{xy}(Y - \bar{Y})$$

$$\Rightarrow X - 90 = 1.363(Y - 70)$$

$$\Rightarrow X - 90 = 1.363Y - 95.41$$

$$\Rightarrow X = 1.363Y - 5.41$$

99. (a) Given; $\sum p_1q_1 = 99, \sum p_0q_1 = 76,$

$$\sum p_0q_0 = 73, \sum p_1q_0 = 96$$

Laspeyre's index number is given by;

$$P_{01}(L) = \frac{\sum p_1q_0}{\sum p_0q_0} \times 100$$

$$= \frac{96}{73} \times 100$$

$$= 131.51(\text{approx})$$

100. (c) We have,

Marks	Number of students (f)	Mid - value (x)	fx
0 - 10	20	$\frac{0+10}{2} = 5$	100
10 - 20	24	$\frac{10+20}{2} = 15$	360
20 - 30	40	$\frac{20+30}{2} = 25$	1000
30 - 40	36	$\frac{30+40}{2} = 35$	1260
40 - 50	20	$\frac{40+50}{2} = 45$	900
	$\sum f = 140$		$\sum fx = 3620$

$$\text{Therefore, Mean} = \frac{\sum fx}{\sum f} = \frac{3620}{140} = 25.85$$

Hence, the Arithmetic mean of given data is 25.85.



Mock Test Paper Series-II

Paper 3: Quantitative Aptitude

All Questions are Compulsory

Time: 2 Hours

Maximum Marks: 100

QUESTIONS

- If the numbers $\frac{1}{4}, \frac{1}{6}, \frac{1}{x}$ and $\frac{1}{15}$ are proportional, then the value of x is
(a) 8 (b) 10
(c) 12 (d) 15
- If $A = \{2, 3\}$ & $B = \{1, 2, 4\}$, then $(A \cup B) \times (A \cap B) =$
(a) $\{(1, 2), (3, 2), (4, 2)\}$
(b) $\{(2, 2)\}$
(c) $\{(1, 2), (2, 2), (3, 2), (4, 2)\}$
(d) $\{(2, 1), (2, 2), (2, 3), (2, 4)\}$
- In an A.P, $a = -29, a_5 = -15$ & $n = 40$, then the sum of all positive terms of this A.P. is
(a) 875 (b) 1200
(c) 1500 (d) 1705
- For the constraints $x \leq 3, y \leq 4$ and $4x + 3y \leq 12$, which of the following points is the point of feasible region?
(a) (2, 3) (b) (1, 1)
(c) (3, 5) (d) (2, 4)
- The time period for which a sum of money amounts to Rs. 400 at 10% p.a. simple interest and amount to Rs. 200 at 4% p.a. simple interest is
(a) 15 years (b) 25 years
(c) 38 years (d) 50 years
- If $a = k, d = -\frac{k}{3}$ and $a_{20} = 32$, then the value of k is
(a) -2 (b) -6
(c) -8 (d) None
- $\lim_{x \rightarrow 2} \frac{x^3 - 8}{x - 2} =$
(a) 7 (b) 8
(c) 12 (d) 14
- Find the roots of the quadratic equation:
 $x^2 + 10 = 7x$
(a) 2 and -5 (b) 2 and 5
(c) 7 and -1 (d) None
- The effective rate of interest on the principal amount of ₹50,000 which is deposited in a bank for 1 year, for which the corresponding nominal interest rate is 8% per annum compounded quarterly is
(Given $(1.02)^4 = 1.0824$)
(a) 8.08% (b) 8.15%
(c) 8.24% (d) 8.50%
- For what value of k the given function is continuous at $x = 2$;
 $f(x) = \{2x + 1, x < 2$
 $= \{k, x = 2$
 $= \{3x - 1, x > 2$
(a) 0 (b) 3
(c) 5 (d) 10
- How many 7-digital telephone numbers can be constructed with digits 0, 1, 2, ...9 such that each number starts from 74 and no digits appears more than once?
(a) 120 (b) 1120
(c) 1680 (d) 6720
- If $x^{2a} = y^{2b} = z^{2c}$ and $y^2 = xz$, then the value of $ab + bc + ca$ is
(a) $2ac$ (b) $3ac$
(c) 0 (d) 3

13. If $\sqrt[3]{x} + \sqrt[3]{y} + \sqrt[3]{z} = 0$, then the value of $(x + y + z)^3$ is

- (a) xyz (b) $3xyz$
 (c) $27xyz$ (d) $81xyz$

14. The compound interest on Rs 40,000 at 12% per annum compounded quarterly for 6 months is

- (a) Rs. 2,643 (b) Rs. 2,463
 (c) Rs. 2,364 (d) Rs. 2,436

15. If $x = 2at^2$ & $y = at^4$, then $\frac{dy}{dx}$ at $t = 1$ is equal to

- (a) 0 (b) -1
 (c) 1 (d) 2

16. The number of 3 digit odd number that can be formed using 3, 4, 5, 6, 7 if the digits can be repeated is

- (a) 5 (b) 25
 (c) 751 (d) 125

17. Suppose you plan to invest ₹ 15,000 annually starting today into a retirement fund for the next 25 year, with an annual interest rate of 7.25%. What would be the present value of these investments?

- (a) ₹1,50,500 (approx) (b) ₹1,61,500 (approx)
 (c) ₹1,73,210 (approx) (d) None

18. If $\log_x a = 4$ and $\log_a y = 2$ then the value of $\log_y x = ?$

- (a) 8 (b) $\frac{1}{8}$
 (c) $\frac{1}{2}$ (d) 2

19. If the difference between the compound interest and simple interest is Rs. 13.77 for 3 year at 6% p.a., then the sum of money is

- (a) Rs. 1120 (b) Rs. 1250
 (c) Rs. 1370 (d) Rs. 1560

20. The total cost of producing x units of a certain product is $C(x) = \frac{1}{3}x^3 - 18x^2 + 160x$, then find the number of units of x that should be produced in order to minimise the marginal cost.

- (a) 18 (b) 16
 (c) 8 (d) 2

21. Which term of the series, 2, $2\sqrt{2}$, 4, is 256?

- (a) 13 (b) 15
 (c) 17 (d) None of these

22. If $y = x^3 + 4^x + \log x$, then find $\frac{dy}{dx}$

- (a) $3x^2 + 4^x + \frac{1}{x}$
 (b) $3x^2 + 4^x \log_e 4 + \frac{1}{x}$
 (c) $3x^2 + 4^x \log_e x + \frac{1}{x}$
 (d) $3x^3 + 4^x \log_e 4 + \frac{1}{x}$

23. $\int 2^{2x} \cdot 3^{2x} \cdot 7^x dx =$

- (a) $\frac{2^{2x} \cdot 3^{2x} \cdot 7^x}{\log 42} + c$
 (b) $\frac{2^{2x} \cdot 3^{2x} \cdot 7^x}{\log 252} + c$
 (c) $2^{2x} \cdot 3^{2x} \cdot 7^x + c$

(d) None of these

24. On simplifying $\frac{(2a^3b^2)^4}{(4a^2b) \times (ab^2)^2}$, we get

- (a) a^3b (b) a^3b^2
 (c) $(a^3b^2)^3$ (d) $(a^3b)^2$

25. In a class of 40 students, 30 passed in Accounts, 25 of them passed in Mathematics and 15 of them passed in both the subjects. Assuming that every student has passed atleast in on subject, then the number of students passed in Accounts, only but not in Mathematics is

- (a) 10 (b) 15
 (c) 22 (d) 30

26. The simple interest on a sum of money for 2 years 8% per annum is ₹ 800. What will be the simple interest for the same sum at 6% per annum for 3 years?

- (a) ₹ 720 (b) ₹ 780
 (c) ₹ 840 (d) ₹ 900

27. If Seema bought an asset 10 years ago worth Rs 85,000 and now sold it for Rs 4,84,050, then her annual return of investment is

- (a) 12% (b) 19%
 (c) 21% (d) 25%

28. Suppose a father had a sum of ₹3,600 and he decided to divide this amount among his three sons Anil, Sunil and Nimal in such a way that 3 times Anil's share, 6 times Sunil's share and 8 times Nimal's share are all equal, then Anil's share is
 (a) ₹ 960 (b) ₹ 1,920
 (c) ₹ 720 (d) ₹ 1,860
29. If $f(x) = x + 2$ & $g(x) = 5^x$, then $gof(x) =$
 (a) $25(5^x) + 5^x$ (b) $5(5^x)$
 (c) $25 + 5^x$ (d) $25(5^x)$
30. Ankita deposits ₹6000 at the start of each quarter in his savings account. If the accountant earns interest 6% per annum compounded quarterly, how much money (in ₹) while he have at the end of 5 years.
 (a) ₹ 120,300 (b) ₹ 130,175
 (c) ₹ 140,823 (d) ₹ 150,805
31. In how many ways can the letters of the word "ALGEBRA" be arranged without changing the relative order of the vowels?
 (a) 82 (b) 70
 (c) 72 (d) None of these
32. Assuming that the discount rate is 8% p.a. How much would you pay to receive ₹ 1000 growing at 6% annually forever?
 (a) ₹ 25,000 (b) ₹ 30,000
 (c) ₹ 45,000 (d) ₹ 50,000
33. A company is offering a five-year bond with a face value of ₹ 20,000 and an annual interest rate of 7%. An investor seeks a return of 9%. What should be the maximum amount the investor is willing to pay for the bond?
 (a) ₹ 16,500 (b) ₹ 17,970
 (c) ₹ 18,990 (d) None
34. The smallest of the three Positive numbers G_1, G_2, G_3 such that $1, G_1, G_2, G_3, 256$ forms a G.P is
 (a) 4 (b) 16
 (c) 64 (d) -16
35. The population after 3 years if the present population is 2,00,000 and the population increases at 3% in 1st year, at 4% in 2nd year and 5% in 3rd year is
 (a) 1,12,476 (b) 1,28,952
 (c) 2,24,952 (d) None of these
36. If in a G.P., the seventh term is 384 and the common ratio is 2, then the first term is
 (a) 3 (b) 6
 (c) 12 (d) 18
37. If 'North-West' is called 'West', 'South-East' is called 'East', 'South-West' is called 'South' and so on, then what will 'North' be called?
 (a) North-East (b) South
 (c) North-West (d) South-East
38. Six friends A, B, C, D, E and F are sitting in a round table facing towards the centre such that E is not sitting between B and D, A is sitting to the left of F and to the second right of C. E is immediate left of D, then who sits immediate right of F?
 (a) D (b) E
 (c) B (d) C
39. Find the sum of the following series;
 105, 110, 115, 995
 (a) 23100 (b) 58450
 (c) 98450 (d) None
40. Five friends A, B, C, D, and E are sitting in a row facing East. A is sitting between C and D. B is second to the left of C. Who is sitting at the South end?
 (a) B (b) E
 (c) C (d) D
41. Sarita leaves her home and walks 30 meters in North-West direction. Then she walks 30 meters in South-West direction, next she walks 30 meters in South-East direction. Finally, she turns towards her house. In which direction is she moving?
 (a) South-West (b) North-West
 (c) South-East (d) North-East
42. Find the missing term of the series: G11T, J35R, P107N, ?
 (a) S321L (b) S323L
 (c) S107L (d) R323L
43. Find missing term of the series 2, 3, 3, 5, 10, 13, 39, ?, 172.
 (a) 42 (b) 43
 (c) 54 (d) 92

44. The graph of the inequalities is drawn below:

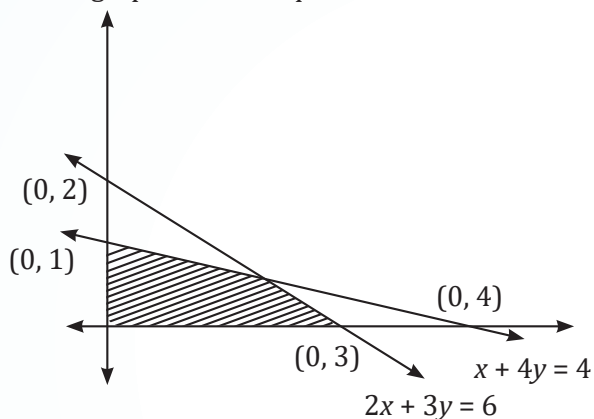

The common region (shaded part) is expressed by the set of inequalities;

- (a) $2x + 3y \leq 6, x + 4y \leq 4, x \geq 0, y \geq 0$
 (b) $2x + 3y \leq 6, x + 4y \geq 4, x \geq 0, y \geq 0$
 (c) $2x + 3y \geq 6, x + 4y \leq 4, x \geq 0, y \geq 0$
 (d) None
45. Anita said, "The man in the picture is my nephew's maternal grandfather." How is the man in the picture related to the Anita?
 (a) Brother (b) Father
 (c) Grandfather (d) Uncle
46. A woman introduced a man as the husband of the sister of her mother's son. The man is the woman's _____?
 (a) Brother (b) Husband
 (c) Uncle (d) Nephew
47. What is the next term of the series: 6, 12, 48, 264, 1560,?
 (a) 9432 (b) 9894
 (c) 9268 (d) 9336
48. Read the information given below to answer the below question;
 There are 9 houses A, B, C, D, E, F, G, H, and I such that C is 2 km East of B. A is 1 km north of house B, G is 1 km west of house H and house H is 2 km South of house A. While house D is 3 km East of G and F is 2 km North of D. Also, house I is situated just in the middle of house B and C whereas house E is just in the middle of house H and D.
 What is the distance between H and D?
 (a) 1 km (b) 2 km
 (c) 2.5 km (d) 3 km

49. Find the sum of n terms of the series;

$$5 + 55 + 555 + \dots$$

- (a) $\frac{5}{81} (10^{n+1} - 10 - 9n)$
 (b) $\frac{5}{9} (10^{n+1} - 10 - 9n)$
 (c) $\frac{5}{81} (10^{n+1} - 10 - n)$
 (d) None of these
50. There are seven friends named A, B, C, D, E, F, G, and H who are sitting in a straight line. F is sitting on the extreme right. B is to the left of E, and D is right to H who is to the left of G. A is to the left of B, and G is to the left of F. Who is in the middle of the line?
 (a) B (b) C
 (c) H (d) F
51. If thrice of A's age 6 years ago be subtracted from twice his present age, the result would be equal to his present age. A's age 4 years ago was
 (a) 9 years (b) 5 years
 (c) 3 years (d) None of these
52. Six friends A, B, C, D, E, and F are sitting in a row facing towards North. C is sitting between A and E. F is not at the right end but D is sitting at 3rd left of E.
 Which of the following is sitting to the right of C?
 (a) D (b) A
 (c) E (d) B
53. If the Harmonic mean of two groups with n_1 and n_2 observations are H_1 & H_2 respectively, then the harmonic mean of combined observation is
 (a) $\frac{n_1 H_1 + n_2 H_2}{n_1 + n_2}$
 (b) $\frac{(n_1 + n_2) H_1 H_2}{n_1 H_1 + n_2 H_2}$
 (c) $\frac{n_1 + n_2}{n_1 H_1 + n_2 H_2}$
 (d) $\frac{n_1 + n_2}{n_1 H_2 + n_2 H_1}$

54. Read the information given below to answer the below question

There are 9 houses A, B, C, D, E, F, G, H and I such that C is 2 km East of B. A is 1 km north of house B, G is 1 km west of house H and house H is 2 km South of house A. While house D is 3 km East of G and F is 2 km North of D. Also, house I is situated just in the middle of house B and C whereas house E is just in the middle of house H and D.

What is the distance between A and I?

- (a) 1 km (b) $\sqrt{2}$ km
(c) 2 km (d) $\sqrt{3}$ km

55. If the Arithmetic mean and coefficient of variation of m are 5 and 20 respectively, then the variance of $10-3m$ is

- (a) 4 (b) 9
(c) 15 (d) 20

56. In a certain code, if CHILDREN is coded as EJKNFTGP then TEACHER in the same code will be coded as

- (a) UFBDIFS (b) VGCEJGT
(c) VHCEKGT (d) None of these

57. The Earning Per share (EPS) of a company for five years is given below:

Year	2019	2020	2021	2022	2023
EPS	40	25	40	60	90

Calculate the Compounded Annual Growth Rate (CAGR) of EPS.

- (a) 24.47% (b) 23.47%
(c) 22.47% (d) 21.47%
58. What is the next term of the series:
6, 16, 44, 126, 370, ?

- (a) 1100 (b) 1250
(c) 1055 (d) None of the above

59. What is the standard deviation of the number of head in 200 tosses of a fair coin?

- (a) 5
(b) $\sqrt{10}$
(c) $5\sqrt{2}$
(d) Cannot be determined

60. At a social event, 5 girls are arranged in a row. M is positioned directly to the right of O and directly to the left of P. N is situated to the immediate right of R, but to the left of O. Who is occupying the central seat?

- (a) O (b) N
(c) M (d) P

61. If the difference between Mean and Median is 23, then the difference between Mean and Mode will be

- (a) 69 (b) 23
(c) 46 (d) None of these

62. The odds in favour of A solving a problem is 2: 3 and the odds in favour of B solving the same problem is 4 : 3. What is the probability that if both of them try, the problem will be solved?

- (a) $\frac{7}{36}$ (b) $\frac{1}{45}$
(c) $\frac{9}{45}$ (d) $\frac{36}{45}$

63. In a college group, there are six friends planning a trip together, denoted by A, B, C, D, E, and F. Among them:

- I. A and C are married.
II. B is the son of C, although C is not B's biological mother.
III. E is C's sibling.
IV. D is A's daughter.
V. F is B's sibling.

How many male members are there in the family?

- (a) 6 (b) 5
(c) 4 (d) 2

64. If Arithmetic mean between two numbers is 5 and Harmonic mean is 3.2, then what is the value of Geometric mean?

- (a) 16 (b) 8
(c) 4 (d) 2

65. If X is an independent variable and Y is dependent variable and S.D of X and Y are 5 and 8 respectively and coefficient of correlation between X and Y is 0.8, then the regression coefficient of Y on X is

- (a) 0.5 (b) 0.86
(c) 1.15 (d) 1.28

66. Five persons A, B, C, D and E are sitting in a circle facing centre. C is sitting immediate left of E. A is sitting between E and D. Who is sitting between B and A?

- (a) D (b) C
(c) E (d) B

67. If $b_{yx} = 0.65$, $b_{xy} = 0.45$, then the value of correlation coefficient is

- (a) 0.32 (b) 0.46
(c) 0.54 (d) 0.65

68. The coefficient of the range of the data: 7, 8, 4, 1, 9, 12, 18, 16, 94, 3, 5, -6 is

- (a) 133.6 (b) 163.3
(c) 166.3 (d) 113.6

69. In a family, there are six members named A, B, C, D, E, and F. B and C are sisters, and D is the only son of A's uncle. E and F are brothers, and F is E's twin sister. What is the relationship between D and F?

- (a) Nephew (b) Brother-in-law
(c) Cousin (d) Uncle

70. The weighted HM of the items 4, 7, 12, 19, 25 having weights 1, 2, 1, 1, 1 respectively is given by;

- (a) 5.68 (b) 6.15
(c) 7.62 (d) 8.43

71. For a set of normally distributed data, the following statistical parameters are; Mean = 6; Median = 5; Standard deviation = 2.6 and Quartile deviation = 1.5, then the coefficient of quartile deviation is

- (a) 25 (b) 28
(c) 30 (d) 33

72. If the standard deviation of a Poisson distribution is 3, then its mode is

- (a) 8 (b) 9
(c) 8 and 9 (d) None

73. If the numbers are 2, 7, 12, 8, 6, then the coefficient of variation is

- (a) 40.50% (b) 46.07%
(c) 56.78% (d) None of the above

74. The Geometric mean of 11, 2, 8, 9, 15, 24, 0, 18 is
(a) 0 (b) 25
(c) 47 (d) 90

75. If the expected values of a random variables x and y are 4.5 and 2.5 respectively, then the expected value of $(x - y)$ is

- (a) 1.5 (b) 2
(c) 2.4 (d) 3.5

76. What type of data is most appropriate for representing using a Pie Chart?

- (a) Continuous data (b) Categorical data
(c) Ordinal data (d) Interval data

77. The mode of the following data;

x	25-30	30-35	35-40	40-45	45-50	50-55
$f(x)$	20	53	42	42	41	43

- (a) 32.50 (b) 33.70
(c) 34.95 (d) 40.50

78. If $P(A) = \frac{1}{3}$, $P(B) = \frac{1}{4}$, $P\left(\frac{A}{B}\right) = \frac{1}{6}$ then $P\left(\frac{B}{A}\right) =$

- (a) $\frac{1}{8}$ (b) $\frac{1}{4}$
(c) $\frac{3}{8}$ (d) $\frac{1}{2}$

79. If $r = \frac{1}{2}$, $\sum xy = 120$, $\sigma_y = 8$, $\sum x^2 = 90$, where

x and y are the deviations from mean, then the value of n is

- (a) 10 (b) 16
(c) 19 (d) 100

80. During a certain period, the cost of living index goes up from 110 to 200 and the salary of a worker is also raised from Rs. 330 to Rs. 500, then in the real terms, the raise in the salary is effectively.

- (a) Gain by Rs. 50 (b) Gain by Rs. 75
(c) Loss by Rs. 90 (d) Loss by Rs. 50

81. A random variable X has the following probability density function; $f(x) = 6x(1 - x)$, $0 \leq x \leq 1$. Then the mean is

- (a) $\frac{1}{3}$ (b) $\frac{1}{12}$
(c) $\frac{1}{4}$ (d) $\frac{1}{2}$

82. A bag contains 7 red balls, 5 blue balls, and 3 green balls. If three balls are drawn from the bag without replacement, what is the probability that exactly two balls are blue?

- (a) $\frac{2}{91}$ (b) $\frac{20}{91}$
 (c) $\frac{17}{45}$ (d) None of the above

83. Non-probability Sampling is known as

- (a) Simple Random Sampling
 (b) Stratified Sampling
 (c) Purposive or Judgement Sampling
 (d) Cluster Sampling

84. If the correlation between two variables x and y is 0.6, then the correlation between x and $-2y$ is

- (a) 0.6 (b) -0.6
 (c) -0.3 (d) None of these

85. In Pie chart, if a category represents 25% of the total data. What will be the angle of the corresponding sector?

- (a) 45° (b) 90°
 (c) 60° (d) 75°

86. If for two events A and B , $P(A \cup B) = 0.6$, $P(A \cap B) = 0.2$ then the value of $P(\bar{A}) + P(\bar{B})$ is

- (a) 1.0 (b) 1.2
 (c) 2.8 (d) None

87. Series in which frequencies are continuously added corresponding to each class interval in the series;

- (a) Frequency
 (b) Cumulative frequency series
 (c) Deviation
 (d) Mid value

88. If the points of inflexion of a normal curve are 40 and 60 respectively, then its mean deviation is

- (a) 4 (b) 8
 (c) 10 (d) 40

89. For Binomial distribution, $E(x) = 6$ and $V(x) = 2$, then the probability of success (p) is

- (a) $\frac{2}{3}$ (b) $\frac{1}{3}$
 (c) $\frac{1}{5}$ (d) None

90. For n pairs of observations, the coefficient of concurrent deviation is calculated as $\frac{1}{\sqrt{2}}$, if there

are six concurrent deviations, then $n =$

- (a) 8 (b) 9
 (c) 11 (d) 13

91. The following table shows the distribution of the ages of a group of people:

Age (in years)	No. of people
20-30	10
30-40	20
40-50	30
50-60	25
60-70	15

How many people are aged 40 years or younger?

- (a) 10 (b) 30
 (c) 50 (d) 60

92. According to the empirical rule, if the data form a "bell-shaped" distribution, then the maximum and minimum frequencies occur _____ at and _____ respectively.

- (a) Middle, left end (b) Middle, right end
 (c) End, Middle (d) Middle, ends

93. The cost of living is always

- (a) Price index number
 (b) Quantity index number
 (c) Weighted index number
 (d) Value index number

94. In a certain manufacturing process, 2% of the tools produced turn out to be defective. Find the probability that in a sample of 100 tools, at least two will be defective.

(Given; $e^{-2} = 0.135$)

- (a) 0.270 (b) 0.595
 (c) 0.624 (d) None

95. If the sum of squares of the deviations from mean of 10 observations is 250, and the mean of the data is 10 then the coefficient of variation is

- (a) 10% (b) 18%
 (c) 30% (d) 50%

96. When the prices for quantities consumed of all commodities are changing in the same ratio, then the index numbers due to Laspeyre's and Paasche's will be

- (a) Equal
- (b) Unequal
- (c) Reciprocal of Marshall Edgeworth's Index number
- (d) Reciprocal of Fisher's Index number

97. A sample of 100 people is taken from a population of 1000. The sample mean height is 170 cm with a standard deviation of 10 cm. What is the standard error of mean?

- (a) 1.0 cm
- (b) 0.5 cm
- (c) 1.58 cm
- (d) 10 cm

98. The Laspeyre's index number is a weighted aggregate method by taking ____ as weight.

- (a) quantity consumed in the base year
- (b) quantity consumed in the current year
- (c) value of items consumed in the base year
- (d) value of items consumed in the current year

99. The quartile deviation of 6 observations; 40, 36, 8, 41, 38, 15 is equal to

- (a) 11.5
- (b) 12.25
- (c) 13.5
- (d) 18.6

100. Find the probability of the number selected out from the numbers 1 to 25, is a multiple of 5 or 7.

- (a) $\frac{2}{25}$
- (b) $\frac{8}{25}$
- (c) $\frac{11}{25}$
- (d) None of these

ANSWER KEY

- | | | | | | | | | | |
|---------|---------|---------|---------|---------|---------|---------|---------|---------|----------|
| 1. (b) | 2. (c) | 3. (d) | 4. (b) | 5. (d) | 6. (b) | 7. (c) | 8. (b) | 9. (c) | 10. (c) |
| 11. (d) | 12. (b) | 13. (c) | 14. (d) | 15. (c) | 16. (c) | 17. (c) | 18. (b) | 19. (b) | 20. (a) |
| 21. (b) | 22. (b) | 23. (b) | 24. (d) | 25. (b) | 26. (d) | 27. (b) | 28. (b) | 29. (d) | 30. (c) |
| 31. (c) | 32. (d) | 33. (c) | 34. (a) | 35. (c) | 36. (b) | 37. (c) | 38. (b) | 39. (c) | 40. (d) |
| 41. (d) | 42. (b) | 43. (b) | 44. (a) | 45. (b) | 46. (b) | 47. (d) | 48. (b) | 49. (a) | 50. (c) |
| 51. (b) | 52. (c) | 53. (b) | 54. (b) | 55. (b) | 56. (b) | 57. (c) | 58. (a) | 59. (c) | 60. (a) |
| 61. (a) | 62. (d) | 63. (c) | 64. (c) | 65. (d) | 66. (a) | 67. (c) | 68. (d) | 69. (c) | 70. (d) |
| 71. (c) | 72. (c) | 73. (b) | 74. (a) | 75. (b) | 76. (b) | 77. (b) | 78. (a) | 79. (a) | 80. (d) |
| 81. (d) | 82. (b) | 83. (c) | 84. (b) | 85. (b) | 86. (b) | 87. (b) | 88. (b) | 89. (a) | 90. (b) |
| 91. (d) | 92. (d) | 93. (c) | 94. (b) | 95. (d) | 96. (a) | 97. (a) | 98. (a) | 99. (c) | 100. (b) |

HINTS & SOLUTIONS

1. (b) Given, $\frac{1}{4}, \frac{1}{6}, \frac{1}{x}$, and $\frac{1}{15}$ are proportional

i.e.,

$$\frac{1}{4} \times \frac{1}{15} = \frac{1}{6} \times \frac{1}{x}$$

$$\Rightarrow \frac{1}{60} = \frac{1}{6x} \Rightarrow x = 10$$

Therefore, the value of x is 10.

2. (c) Given; $A = \{2, 3\}$ & $B = \{1, 2, 4\}$

$$\Rightarrow A \cup B = \{1, 2, 3, 4\} \text{ \& } (A \cap B) = \{2\}$$

$$\Rightarrow (A \cup B) \times (A \cap B)$$

$$= \{1, 2, 3, 4\} \times \{2\}$$

$$= \{(1, 2), (2, 2), (3, 2), (4, 2)\}$$

3. (d) Given; $a = -29, a_5 = -15$ & $n = 40$

We know,

$$a_5 = a + 4d$$

$$\Rightarrow -15 = -29 + 4d \Rightarrow 4d = 14$$

$$\Rightarrow d = \frac{7}{2} = 3.5$$

Now, to find the sum of all positive terms of this A.P.:

Negative terms: $-29, -25.5, -22, -18.5, -15, -11.5, -8, -4.5, -1, 2.5, 6, 9.5, \dots$

Number of positive terms = $40 - 9 = 31$
 (subtracting 9 negative terms as shown above)
 Therefore, sum of all positive terms i.e., sum of 31 positive terms is given by:

$$S_{31} = \frac{31}{2} \times [5 + 30(3.5)]$$

$$S_{31} = 1705$$

4. (b) Given; $x \leq 3, y \leq 4$ and $4x + 3y \leq 12$

Go by option:

For (A): (2,3)

$2 \leq 3$ which is true,

$3 \leq 4$, which is true

$4(2) + 3(3) = 17 \not\leq 12$,

For (B): (1, 1)

$1 \leq 2$, which is true

$1 \leq 4$, which is true

$4(1) + 3(1) = 7 \leq 12$, which is also true.

Hence, (1, 1) is the required point.

5. (d) Given; A sum of money amounts to Rs 400 at 10% p.a. simple interest and amounts to Rs 200 at 4% p.a. simple interest i.e.,

$$400 = P(1 + 0.1t) \quad \dots(i)$$

$$200 = P(1 + 0.04t) \quad \dots(ii)$$

On dividing both the equations, we get

$$\frac{400}{200} = \frac{P(1+0.1t)}{P(1+0.04t)}$$

$$\Rightarrow 2 = \frac{(1+0.1t)}{(1+0.04t)}$$

$$\Rightarrow 2 + 0.08t = 1 + 0.1t$$

$$\Rightarrow 1 = 0.02t$$

$$\Rightarrow t = \frac{1}{0.02} = 50 \text{ years}$$

6. (b) Given; $a = k, d = -\frac{k}{3}$ and $a_{20} = 32$

We know that,

$$a_n = a + (n - 1)d$$

$$\Rightarrow a_{20} = a + (20 - 1)d$$

$$\Rightarrow 32 = k + 19\left(-\frac{k}{3}\right)$$

$$\Rightarrow 32 = k - \frac{19k}{3}$$

$$\Rightarrow 32 = k - \frac{19k}{3}$$

$$\Rightarrow 32 = -\frac{16k}{3}$$

$$k = -6$$

Therefore, the value of k is -6

7. (c) $\lim_{x \rightarrow 2} \frac{x^3 - 8}{x - 2}$

$$= \lim_{x \rightarrow 2} \frac{x^3 - (2)^3}{x - 2}$$

$$= \lim_{x \rightarrow 2} \frac{(x-2)(x^2 + 4 + 2x)}{x - 2}$$

$$[a^3 - b^3 = (a - b)(a^2 + ab + b^2)]$$

$$= \lim_{x \rightarrow 2} (x^2 + 4 + 2x)$$

$$= (2)^2 + 4 + 2(2) = 12$$

8. (b) Given, $x^2 + 10 = 7x$

$$\Rightarrow x^2 - 7x + 10 = 0$$

$$\Rightarrow x^2 - 5x - 2x + 10 = 0$$

$$\Rightarrow x(x - 5) - 2(x - 5) = 0$$

$$\Rightarrow (x - 2)(x - 5) = 0 \quad x = 2 \text{ or } x = 5$$

Therefore, the roots of the equation are 2 and 5.

9. (c) According to question, we have

Rate of interest (r) = 8%

Number of conversion period, $m = 4$

We know that,

Effective rate of interest is given by;

$$E = \left[\left(1 + \frac{r}{m} \right)^m - 1 \right] \times 100$$

$$\Rightarrow E = \left[\left(1 + \frac{0.08}{4} \right)^4 - 1 \right] \times 100$$

$$\Rightarrow E = [(1.02)^4 - 1] \times 100$$

$$\Rightarrow E = (1.0824 - 1) \times 100\%$$

$$\Rightarrow E = 0.0824 \times 100\% \Rightarrow E = 8.24\%$$

10. (c) Given;

$$f(x) = \{2x + 1, x < 2$$

$$= \{k, x = 2$$

$$= \{3x - 1, x > 2$$

Since, the function is continuous at $x = 2$

$$\text{Thus, } \lim_{x \rightarrow 2^-} f(x) = f(2) = \lim_{x \rightarrow 2^+} f(x)$$

$$\Rightarrow \lim_{x \rightarrow 2^-} (2x + 1) = k = \lim_{x \rightarrow 2^+} (3x + 1)$$

$$\Rightarrow 2(2) + 1 = k = 3(2) - 1 \Rightarrow k = 5$$

Therefore, the required value of k is 5.

11. (d) To construct; 7-digital telephone numbers
Since, each number starts from 74
Thus, the remaining 8-digits can fill up the
remaining 5 vacant position in 8P_5 ways

$$\Rightarrow {}^8P_5 = \frac{8!}{3!}$$

$$\Rightarrow {}^8P_5 = 6720$$

12. (b) Given; $x^{2a} = y^{2b} = z^{2c}$ and $y^2 = xz$

$$(x^a)^2 = (y^b)^2 = (z^c)^2$$

$$\Rightarrow x^a = y^b = z^c = k \text{ (Let)}$$

$$\Rightarrow x^a = k, y^b = k, z^c = k$$

$$\Rightarrow x = k^{\frac{1}{a}}, y = k^{\frac{1}{b}}, \text{ \& } z = k^{\frac{1}{c}}$$

$$\text{Now, } y^2 = xz$$

$$\Rightarrow \left(k^{\frac{1}{b}}\right)^2 = k^{\frac{1}{a}} \cdot k^{\frac{1}{c}}$$

$$\Rightarrow k^{\frac{2}{b}} = k^{\frac{1}{a} + \frac{1}{c}}$$

$$\Rightarrow \frac{2}{b} = \frac{1}{a} + \frac{1}{c}$$

$$\Rightarrow \frac{2}{b} = \frac{c+a}{ac}$$

$$\Rightarrow 2ac = b(c+a)$$

$$\Rightarrow bc + ab = 2ac$$

$$\Rightarrow ab + bc + ca = 2ac + ac$$

$$\Rightarrow ab + bc + ca = 3ac$$

13. (c) Given; $\sqrt[3]{x} + \sqrt[3]{y} + \sqrt[3]{z} = 0$

We know,

$$\text{If } a + b + c = 0, \text{ then } a^3 + b^3 + c^3 = 3abc$$

$$\text{Here, } a = \sqrt[3]{x}, b = \sqrt[3]{y} \text{ \& } c = \sqrt[3]{z}, \text{ then}$$

$$\Rightarrow (\sqrt[3]{x})^3 + (\sqrt[3]{y})^3 + (\sqrt[3]{z})^3$$

$$= 3(\sqrt[3]{x})(\sqrt[3]{y})(\sqrt[3]{z})$$

$$\Rightarrow x + y + z = 3\sqrt[3]{xyz}$$

$$\Rightarrow (x + y + z)^3 = \left(3\sqrt[3]{xyz}\right)^3$$

$$\Rightarrow (x + y + z)^3 = 27xyz$$

14. (d) Given; P = Rs 40,000, R = 12% and T = 6
months = $\frac{6}{12} = \frac{1}{2}$ year

Since, it is compounded quarterly thus n = 4

$$\text{Therefore, Amount} = 40,000 \left(1 + \frac{12}{400}\right)^2$$

$$= 40,000 \left(\frac{103}{100}\right)^2$$

$$= \text{Rs. } 42,436$$

$$\text{Therefore, C.I} = \text{Rs. } 42,436 - \text{Rs } 40,000 = \text{Rs } 2,436$$

Trick:

$$\text{The required compound interest} = 40,000 + 3\% + 3\% - 40,000 = \text{Rs. } 2,436$$

15. (c) Given; $x = 2at^2$ \& $y = at^4$

$$\Rightarrow \frac{dx}{dt} = 4at$$

$$\Rightarrow \frac{dy}{dt} = 4at^3$$

$$\text{Now, } \frac{dy}{dx} = \frac{\frac{dy}{dt}}{\frac{dx}{dt}}$$

$$\Rightarrow \frac{dy}{dx} = \frac{4at^3}{4at}$$

$$\Rightarrow \frac{dy}{dx} = t^2$$

Therefore, at $t = 1$

$$\frac{dy}{dx} = (1)^2 = 1$$

16. (c) Given digits; 3, 4, 5, 6, 7

For the number to be odd, the unit place can be filled in 3 ways (3, 5, 7)

Now, the tens and hundreds place can be filled in 5 ways each.

$$\text{Thus, Number of 3-digit odd numbers} = 5 \times 5 \times 3 = 75$$

17. (c) Given;

$$A = ₹ 15,000, r = 7.25\% \text{ p.a., } c = 1, n = 25 \text{ years}$$

Since, the annuity is starting from today i.e., it is the case of annuity immediate.

Therefore, the present value of annuity is given by:

$$PV = \frac{A \left[1 - (1+i)^{-n}\right]}{i} \times (1+i)$$

$$= \frac{15000 \left[1 - (1 + 0.0725)^{-25} \right]}{0.0725} \times (1 + 0.0725)$$

$$= \frac{15000 \left[1 - (1.0725)^{-25} \right]}{0.0725} \times (1.0725)$$

$$= 1,73,210 (\text{approx})$$

18. (b) Given; $\log_x a = 4$ and $\log_a y = 2$

$$\Rightarrow \frac{\log a}{\log x} = 4 \text{ \& } \frac{\log y}{\log a} = 2$$

$$\Rightarrow \frac{\log a}{\log x} \times \frac{\log y}{\log a} = 4 \times 2$$

$$\Rightarrow \frac{\log y}{\log x} = 8$$

$$\Rightarrow \frac{\log x}{\log y} = \frac{1}{8}$$

$$\Rightarrow \log_y x = \frac{1}{8}$$

19. (b) We know that,
Difference between compound interest and simple interest for 3 years is given by

$$C.I. - S.I. = Pi^2(i+3)$$

$$\Rightarrow 13.77 = P \left(\frac{6}{100} \right)^2 (0.06 + 3)$$

$$\Rightarrow P = \frac{13.77}{(0.06)^2 (3.06)}$$

$$\Rightarrow P = \text{Rs } 1250$$

20. (a) Given, $C(x) = \frac{1}{3}x^3 - 18x^2 + 160x$

We know

$$\text{Marginal Cost (MC)} = \frac{dC}{dx}$$

$$\frac{dC}{dx} = \frac{d}{dx} \left(\frac{1}{3}x^3 - 18x^2 + 160x \right)$$

$$= \frac{1}{3}(3x^2) - 18(2x) + 160$$

$$= x^2 - 36x + 160$$

$$\text{Now, } \frac{d(MC)}{dx} = \frac{d}{dx} (x^2 - 36x + 160) = 2x - 36$$

$$\text{Put, } \frac{d(MC)}{dx} = 0$$

$$\Rightarrow 2x - 36 = 0$$

$$\Rightarrow x = 18$$

$$\text{Thus, } \frac{d^2(MC)}{dx^2} = 2$$

$$\text{i.e., } \left[\frac{d^2(MC)}{dx^2} \right]_{x=18} = 2 > 0$$

Therefore, the marginal cost is minimum at $x = 18$.

21. (b) That,

Given, series; $2, 2\sqrt{2}, 4, \dots$

Here, the common ratio is same thus the given series is G.P.

$$a = 2, r = \sqrt{2}$$

Let nth term of G.P. be 256, then

$$t_n = ar^{n-1}$$

$$\Rightarrow 256 = 2(\sqrt{2})^{n-1}$$

$$\Rightarrow 128 = (\sqrt{2})^{n-1}$$

$$\Rightarrow 2^7 = 2^{\frac{n-1}{2}}$$

$$\Rightarrow \frac{n-1}{2} = 7$$

$$\Rightarrow n - 1 = 14$$

$$\Rightarrow n = 15$$

22. (b) Given, $y = x^3 + 4^x + \log x$

Differentiating above wrt x , we get

$$\frac{dy}{dx} = \frac{d}{dx} (x^3 + 4^x + \log x)$$

$$= \frac{d}{dx} (x^3) + \frac{d}{dx} (4^x) + \frac{d}{dx} (\log x)$$

$$= 3x^2 + 4^x \log_e 4 + \frac{1}{x}$$

23. (b) $\int 2^{2x} \cdot 3^{2x} \cdot 7^x dx$

$$\Rightarrow \int (2^2)^x \cdot (3^2)^x \cdot 7^x dx$$

$$\Rightarrow \int 4^x \cdot 9^x \cdot 7^x dx$$

$$\Rightarrow \int (4 \times 9 \times 7)^x dx$$

$$\Rightarrow \int (252)^x dx$$

$$\Rightarrow \frac{(252)^x}{\log 252} + c \Rightarrow \frac{2^{2x} \cdot 3^{2x} \cdot 7^x}{\log 252} + c$$

$$\begin{aligned}
 24. \text{ (d)} \quad & \frac{(2a^3b^2)^4}{(4a^2b)^2 \times (ab^2)^2} \\
 &= \frac{2^4(a^3)^4(b^2)^4}{4^2(a^2)^2 b^2 \times a^2 b^4} \\
 &= \frac{16a^{12}b^8}{16a^4b^2 \times a^2b^4} \\
 &= \frac{a^{12}b^8}{a^{4+2}b^{2+4}} \\
 &= \frac{a^{12}b^8}{a^6b^6} \\
 &= a^{12-6}b^{8-6} = a^6b^2 = (a^3b)^2
 \end{aligned}$$

25. (b) According to given data, we have

$$n(A \cup M) = n(S) = 40$$

Also

$$n(A) = 30, n(M) = 25 \text{ \& } n(A \cap B) = 15$$

Therefore, the number of students passed in Accounts only but not in Mathematics is given by

$$n(A \cap M') = n(A) - n(A \cap M)$$

$$\Rightarrow n(A \cap M') = 30 - 15$$

$$n(A \cap M') = 15$$

26. (d) According to the question

$$S.I. = ₹800, T = 2 \text{ Years and } R = 8\%$$

We know that,

$$S.I. = \frac{P \times R \times T}{100}$$

$$\Rightarrow 800 = \frac{P \times 8 \times 2}{100}$$

$$\Rightarrow P = \frac{800 \times 100}{8 \times 2} = 5000$$

Now, when $P = ₹5000, T = 3 \text{ years and } R = 6\%$

$$\Rightarrow S.I. = \frac{P \times R \times T}{100}$$

$$\Rightarrow S.I. = \frac{5000 \times 6 \times 3}{100}$$

$$\Rightarrow S.I. = 900$$

Therefore, the required simple interest is ₹900.

27. (b) According to question, we have

$$A = \text{Rs. } 4,84,050, P = \text{Rs. } 85,000 \text{ \& } t = 10 \text{ years}$$

Thus,

$$A = P(1+i)^n$$

$$\Rightarrow 4,84,050 = 85000(1+i)^{10}$$

$$\Rightarrow (1+i)^{10} = 5.6947 \Rightarrow 1+i = 1.19$$

$$\Rightarrow i = 0.19 \text{ or } 19\%$$

Therefore, the annual rate of investment is 19%.

28. (b) Since, 3 times Anil's share, 6 times Sunil's share and 8 times Nimal's share are all equal i.e.,

$$3A = 6B = 8C$$

$$\Rightarrow \frac{3A}{24} = \frac{6B}{24} = \frac{8C}{24}$$

$$\Rightarrow \frac{A}{8} = \frac{B}{4} = \frac{C}{3}$$

Therefore, Anil's share is given by;

$$\frac{8}{8+4+3} \times 3600$$

$$= \frac{8}{15} \times 3600 = ₹1920$$

29. (d) Given; $f(x) = x + 2$ \& $g(x) = 5^x$

Thus, $g \circ f(x) = g(f(x))$

$$\Rightarrow g(x+2)$$

$$\Rightarrow 5^{x+2}$$

$$\Rightarrow 5^x \cdot 5^2 \Rightarrow 25(5^x)$$

30. (c) Since, Ankita deposits at the start of each quarter, thus it is the case of annuity immediate.

Here,

$$A = ₹6000, r = 6\% \text{ p.a., } c = 4, n = 5 \text{ years}$$

$$\Rightarrow i = \frac{6}{4}\% = 1.5\%$$

Thus,

$$FV = \frac{A \left[(1+i)^{4n} - 1 \right]}{i} \times (1+i)$$

$$= \frac{6000 \left[\left(1 + \frac{1.5}{100} \right)^{20} - 1 \right]}{\frac{1.5}{100}} \times \left(1 + \frac{1.5}{100} \right)$$

$$= \frac{6000 \times 100 \left[(1.015)^{20} - 1 \right]}{1.5} \times (1.5)$$

$$= ₹140,823 \text{ (approx)}$$

31. (c) Given word: "ALGEBRA"

Total letters: 7

Since, the relative order of the vowels should not be changed thus

i.e., vowels (A, E, A) can arranged themselves in $\frac{3!}{2!}$ ways

Consonants (L, G, B, R) can be arranged themselves in $4!$ ways

V C C V C C V

i.e., vowels (A, E, A) can arranged themselves in $\frac{3!}{2!}$ ways

Consonants (L, G, B, R) can be arranged themselves in $4!$ ways

Therefore, the total ways

$$= \frac{3!}{2!} \times 4! = 3 \times 24 = 72 \text{ ways.}$$

32. (d) We know that,

$$PV A = \frac{A}{i - g}$$

$$= \frac{1000}{0.08 - 0.06} = \frac{1000}{0.02}$$

$$= 1000 \times \frac{100}{2} = 50,000$$

Therefore, the required amount is ₹50,000.

33. (c) Given: Nominal interest rate = 7%

Rate of return = 9%

Face value = ₹20,000

Thus,

$$7\% \text{ of } ₹20,000 = \frac{7}{100} \times 20,000 = ₹1400$$

Therefore, Present value of bond

$$= \frac{1400}{(1+0.09)^1} + \frac{1400}{(1+0.09)^2} + \frac{1400}{(1+0.09)^3} + \frac{20000}{(1+0.09)^3}$$

$$= \frac{1400}{(1.09)^1} + \frac{1400}{(1.09)^2} + \frac{1400}{(1.09)^3} + \frac{20000}{(1.09)^3}$$

$$= \frac{1400}{(1.09)^1} + \frac{1400}{(1.09)^2} + \frac{21400}{(1.09)^3}$$

$$= 1284.40 + 1178.35 + 16524.73$$

$$= 18990 \text{ (approx.)}$$

34. (a) Since, $1, G_1, G_2, G_3, 256$

$$\Rightarrow a = 1, t_5 = 256$$

$$\Rightarrow ar^4 = 256$$

$$\Rightarrow (1)r^4 = 256$$

$$\Rightarrow r = \sqrt[4]{256} = \pm 4$$

When $r = 4$

$$G_1 = (1)(4) = 4$$

$$G_2 = (1)(4)^2 = 16$$

$$G_3 = (1)(4)^3 = 64$$

When $r = -4$

$$G_1 = (1)(-4) = -4$$

$$G_2 = (1)(-4)^2 = 16$$

$$G_3 = (1)(-4)^3 = -64$$

Since, G_1, G_2, G_3 , are positive.

Thus, the series is 4, 16, 64.

Therefore, the smallest number is 4.

35. (c) Given; the present population (P) = 2,00,000

Here, $r_1 = 3\%$, $r_2 = 4\%$ & $r_3 = 5\%$

Therefore, the population after 3 years is

$$\begin{aligned} & P(1+r_1)(1+r_2)(1+r_3) \\ &= 200000(1+0.03)(1+0.04)(1+0.05) \\ &= 2,24,952 \end{aligned}$$

Hence, the population after 3 years is 2,24,952.

36. (b) Given: $t_7 = 384$ and $r = 2$

We know that, nth term of G.P. is given by:

$$t_n = ar^{n-1}$$

$$\Rightarrow t_7 = ar^{7-1}$$

$$\Rightarrow t_7 = ar^6$$

$$\Rightarrow 384 = a(2)^6$$

$$\Rightarrow a = \frac{384}{64} = 6$$

Therefore, the first term of G.P. is 6.

37. (c) We know,

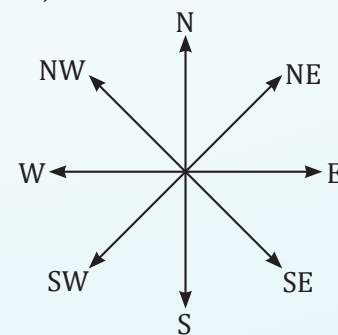

Since, 'North-West' is called 'West', 'South-East' is called 'East', 'South-West' is called 'South', thus 'North' will be called as 'North-West'.

38. (b) According to given information, we have

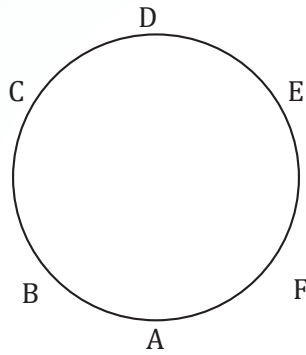

Therefore, E sits to the right of F.

39. (c) Given series; 105, 110, 115, 995

Clearly, it is an A.P with
 $a = 105, d = 5$ & $a_n = 995$

We know that,

$$a_n = a + (n - 1)d$$

$$\Rightarrow 995 = 105 + (n - 1)5$$

$$\Rightarrow 5n = 895$$

$$\Rightarrow n = 179$$

Sum of n terms of an A.P, $S_n = \frac{n}{2} [a + a_n]$

$$\Rightarrow S_n = \frac{179}{2} [105 + 995]$$

$$\Rightarrow S_n = \frac{179}{2} \times 1100$$

$$\Rightarrow S_n = 98450$$

40. (d) Given; Five friends A, B, C, D and E are sitting in a row facing East.

Also, A is sitting between C and D and B is second to the left of C, thus the final arrangement will be;

B
 E
 C
 A
 D

Therefore, D is sitting at the south end.

41. (d) Following the directions as per the question, we get,

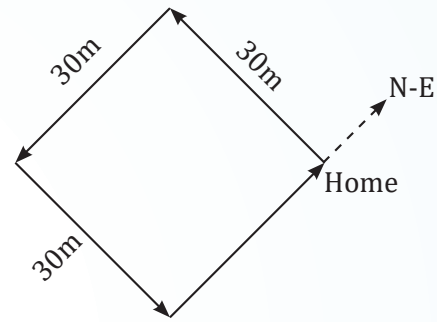

Therefore, she is moving in North-East direction.

42. (b) Given series, G11T, J35R, P107N, ?

Here, the pattern of the numbers is:

$$3 \times 3 + 2 = 9 + 2 = 11$$

$$11 \times 3 + 2 = 33 + 2 = 35$$

$$35 \times 3 + 2 = 105 + 2 = 107$$

$$107 \times 3 + 2 = 321 + 2 = 323$$

i.e., the last term should be S323L.

Therefore, S323L is missing term of the series.

43. (b) Given series, 2, 3, 3, 5, 10, 13, ?, 43, 172

The pattern here is:

$$2 + 1 = 3$$

$$3 \times 1 = 3$$

$$3 + 2 = 5$$

$$5 \times 2 = 10$$

$$10 + 3 = 13$$

$$13 \times 3 = 39$$

$$39 + 4 = 43$$

44. (a)

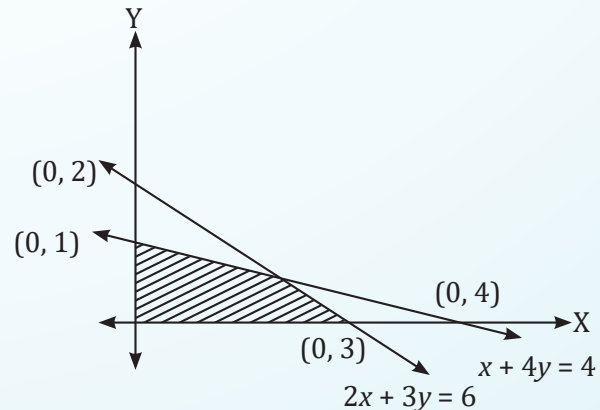

Clearly, at $(0, 0)$

$$2x + 3y = 2(0) + 3(0) = 0 \leq 6$$

$$\text{Also, } x + 4y = 0 + 4(0) = 0 \leq 4$$

Since, $x \geq 0, y \geq 0$

Therefore, the required set of inequalities are:

$$2x + 6y \leq 6, x + 4y \leq 4, x \geq 0, y \geq 0$$

45. (b) We know,

Maternal grandfather means the grandfather from the mother's side.

Nephew means the son of a sibling.

So, if the Anita's nephew's maternal grandfather is the man in the picture, it means that the man is the father of Anita. The maternal grandfather is Anita's father, as he is related to her through her mother's side.

Therefore, the man is the father of Anita.

46. (b) Here, the woman's mother's son refers to the woman's brother.

Also, the sister of the woman's brother refers to the woman herself.

Since, the woman introduced the man as the husband of her sister. Therefore, the man is the woman's sister's husband.

Hence, the correct option is (b) i.e., Husband.

47. (c) Given series: 6, 12, 48, 264, 1560, ?

On observing the pattern, we see

$$6 + 6^1 = 12$$

$$12 + 6^2 = 12 + 36 = 48$$

$$48 + 6^3 = 48 + 216 = 264$$

$$264 + 6^4 = 264 + 1296 = 1560$$

$$1560 + 6^5 = 1560 + 7776 = 9336$$

Therefore, the missing term is 9336.

48. (b) According to given data, we have

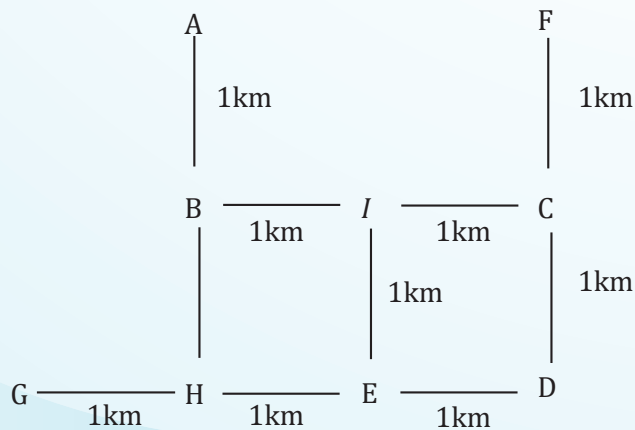

Clearly, the distance between H and D is 2 km.

49. (a) Given series; 5 + 55 + 555 +

$$S_n = 5 + 55 + 555 + \dots$$

$$= 5(1 + 11 + 111 + \dots)$$

$$= \frac{5}{9} (9 + 99 + 999 + \dots)$$

$$= \frac{5}{9} [(10 - 1) + (100 - 1) + (1000 - 1) + \dots]$$

$$= \frac{5}{9} [(10 + 100 + 1000 + \dots n \text{ terms})$$

$$- (1 + 1 + 1 + \dots n \text{ terms})]$$

$$= \frac{5}{9} \left[\frac{10(10^n - 1)}{10 - 1} - n \right]$$

$$= \frac{5}{9} \left[\frac{10(10^n - 1)}{9} - n \right]$$

$$= \frac{5}{81} (10^{n+1} - 10 - 9n)$$

50. (c) Given: A is to the left of B and B is to the left of E i.e., A B E

Also, D is right to H and who is to the left of G i.e., H D G

Now, G is to the left of F and F is on the extreme right i.e., G F

Thus, A B E H D G F

Therefore, H is sitting in the middle. Hence, the correct option is (c) i.e., H.

51. (b) Let the present age of A be x years.

Thus, A's age 6 years ago = ' $x - 6$ ' years

According to the question,

$$2x - 3(x - 6) = x$$

$$\Rightarrow 2x - 3x + 18 = x$$

$$\Rightarrow -x + 18 = x \Rightarrow 2x = 18$$

$$\Rightarrow x = 9$$

Therefore, A's age 4 years ago was ' $9 - 4 = 5$ ' years.

52. (c) According to the information,

C is sitting between A and E i.e., ACE 'or' ECA

B is sitting at immediate right of E i.e., A C E B

D is sitting at 3rd left of E i.e., D A C E B

Since, F is not at the right end and D is not at the end thus the final arrangement is: F D A C E B

Therefore, E is sitting to the right of C.

53. (b) We know that, Harmonic mean is given by;

$$H.M = \frac{n_1 + n_2}{\frac{n_1}{H_1} + \frac{n_2}{H_2}}$$

$$\Rightarrow H.M = \frac{n_1 + n_2}{\frac{n_1 H_2 + n_2 H_1}{H_1 H_2}}$$

$$\Rightarrow H.M = \frac{(n_1 + n_2) H_1 H_2}{n_1 H_2 + n_2 H_1}$$

54. (b) According to given data, we have

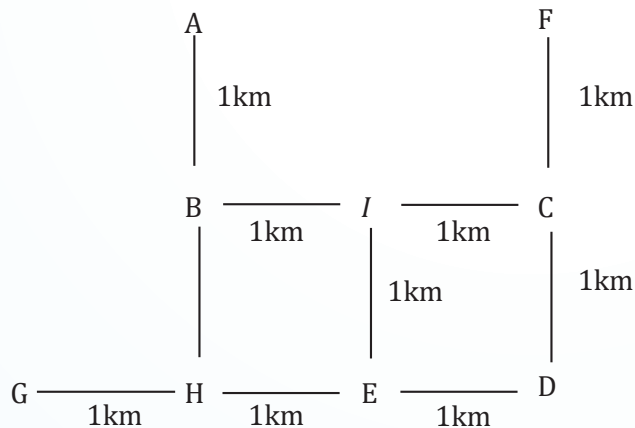

Clearly, the distance between A and I is given by

$$AI = \sqrt{AB^2 + BI^2}$$

$$\Rightarrow AI = \sqrt{1+1}$$

$$\Rightarrow AI = \sqrt{2} \text{ km}$$

55. (b) According to question, we have

$$\bar{m} = 5 \text{ \& } C.V_m = 20$$

We know,

$$C.V_m = \frac{\sigma_m}{\bar{m}} \times 100$$

$$\Rightarrow 20 = \frac{\sigma_m}{5} \times 100$$

$$\Rightarrow \sigma_m = 1$$

$$\text{Let } x = 10 - 3m$$

$$x = -3m + 10$$

$$\Rightarrow \sigma_x = |-3| \times \sigma_m$$

$$\Rightarrow \sigma_x = 3 \times 1$$

$$\Rightarrow \sigma_x = 3$$

Therefore, the variance will be $\sigma_x^2 = (3)^2 = 9$.

56. (b) Given; CHILDREN is coded as EJKNFTGP

$$\text{i.e. } C + 2 = E, H + 2 = J$$

$$I + 2 = K, L + 2 = N$$

$$D + 2 = F, R + 2 = T, E + 2 = G$$

$$N + 2 = P$$

Similarly, TEACHER will be coded as

$$T + 2 = V$$

$$E + 2 = G$$

$$A + 2 = C$$

$$C + 2 = E$$

$$H + 2 = J$$

$$E + 2 = G$$

$$R + 2 = T$$

Therefore, TEACHER will be coded as 'VGCEJGT'!

57. (c) According to data,

Year	2019	2020	2021	2022	2023
EPS	40	25	40	60	90

Therefore, CAGR =

$$\left(\frac{90}{40}\right)^{\frac{1}{4}} - 1 = (2.25)^{\frac{1}{4}} - 1 = 22.47\%$$

58. (a) Given series: 6, 16, 44, 126, 370, ?

On observing the series, we get

$$6 \times 3 - 2 = 16$$

$$16 \times 3 - 4 = 44$$

$$44 \times 3 - 6 = 126$$

$$126 \times 3 - 8 = 370$$

$$370 \times 3 - 1 = 1100$$

Therefore, the missing term is 1100.

Hence, the correct option is (a) i.e., 1100.

59. (c) According to the question, we have

$$n = 200, p = \frac{1}{2}, \text{ and } q = \frac{1}{2}$$

We know that,

$$\text{Standard deviation} = \sqrt{npq}$$

$$= \sqrt{200 \times \frac{1}{2} \times \frac{1}{2}} = \sqrt{50} = 5\sqrt{2}$$

60. (a) According to the given information, we have

M is positioned directly to the right of O and directly to the left of P

O M P

Now, N is situated to the immediate right of R, but to the left of O i.e.,

RNO

Therefore, the arrangement is:

RNOP

Thus, O is at the central seat.

Hence, the correct option is (a).

61. (a) We know that,
Mean - Mode = 3(Mean - Median)
= $3 \times 23 = 69$
Hence, option (a) is correct.
62. (d) Given; odds in favour of A solving a problem = 2 : 3
Odds in favour of B solving the same problem = 4 : 3

$$\text{i.e., } P(A) = \frac{2}{5} \text{ \& } P(B) = \frac{4}{7}$$

Now, P (problem will be solved)

$$= 1 - P(\text{Problem not solved})$$

$$= 1 - P(\bar{A}) \cdot P(\bar{B})$$

$$= 1 - (1 - P(A))(1 - P(B))$$

$$= 1 - \left(1 - \frac{2}{5}\right) \left(1 - \frac{4}{7}\right) = 1 - \frac{3}{5} \cdot \frac{3}{7}$$

$$= 1 - \frac{9}{45} = \frac{36}{45}$$

63. (c) According to the question,
Total members = 6
 B is the son of C but C is not the mother of B i.e.,
 B is a male and C is a male too as C is the father of B .
Also, A and C are married couple
i.e., C is a male, thus A is a female.
Now, E is the brother of C thus E is a male.
 D is the daughter of A i.e., D is a female.
 F is the brother of B i.e., F is a male.
 B, C, E, F are males and D, A are females.
Therefore, there are 4 males in the family.

64. (c) Given, $A.M = 5$ and $H.M = 3.2$

We know that,

$$G.M^2 = A.M \times H.M$$

$$\Rightarrow G.M^2 = 5 \times 3.2$$

$$\Rightarrow G.M^2 = 16$$

$$\Rightarrow G.M = 4$$

Therefore, the required $G.M$ is 4.

65. (d) Given: $\sigma_x = 5, \sigma_y = 8$ and $r = 0.8$

Therefore, the regression coefficient of Y on X is given by

$$b_{yx} = r \times \frac{\sigma_y}{\sigma_x}$$

$$\Rightarrow b_{yx} = 0.8 \times \frac{8}{5}$$

$$\Rightarrow b_{yx} = 1.28$$

66. (a) Given; Five persons A, B, C, D and E are sitting in a circle facing centre

Also, C is sitting immediate left of E and A is sitting between E and D , thus the final arrangement be;

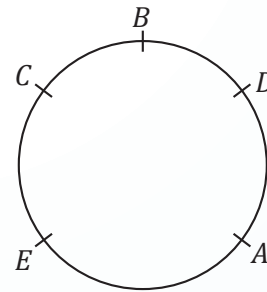

Therefore, D is sitting between B and A ,

67. (c) We know that,

$$r^2 = b_{xy} \times b_{yx}$$

$$\Rightarrow r^2 = 0.65 \times 0.45$$

$$\Rightarrow r^2 = \sqrt{0.65 \times 0.45}$$

$$\Rightarrow r^2 = 0.54$$

68. (d) Given data; 7, 8, 4, 1, 9, 12, 16, 94, 3, 5, -6

Here, Largest observation = 94

Smallest observation = -6

Therefore, Coefficient of range

$$= \frac{94 - (-6)}{94 + (-6)} \times 100 = \frac{100}{88} \times 100 = 113.6$$

69. (c) B and C are sisters, which means they are the daughters of the same parents.

D is the only son of A 's uncle, which makes D the cousin of A, B , and C .

E and F are brothers, and F is E 's twin sister, which means they are siblings.

Since D is the cousin of B and C and F is the sibling of E who is the brother of D 's father, then D and F are also cousins.

70. (d) We know,

$$\begin{aligned} \text{Weighted HM} &= \frac{\sum W}{\sum \left(\frac{W}{X} \right)} \\ &= \frac{1+2+1+1+1}{\frac{1}{4} + \frac{2}{7} + \frac{1}{12} + \frac{1}{19} + \frac{1}{25}} \\ &= \frac{6}{0.2500 + 0.2857 + 0.0833 + 0.0526 + 0.0400} \\ &= \frac{6}{0.7116} \\ &= 8.43 \text{ (apprx.)} \end{aligned}$$

71. (c) We know that,

Coefficient of quartile deviation is given by;
 $\frac{\text{Quartile deviation}}{\text{Median}} \times 100$

$$= \frac{1.5}{5} \times 100 = 0.3 \times 100 = 30$$

72. (c) Given; Standard deviation of a Poisson distribution = 3

$$\Rightarrow \sqrt{m} = 3 \Rightarrow m = 9$$

Since, m is an integer, thus its mode is given by m & $m - 1$

$$\Rightarrow 9 \text{ \& } 9 - 1 \Rightarrow 9 \text{ \& } 8$$

73. (b) The mean of data set is given by the sum of data divided by total numbers of data values i.e.,

$$\bar{X} = \frac{\sum X}{N}$$

$$\text{Mean, } \bar{X} = \frac{2+7+12+8+6}{5} = \frac{35}{5} = 7$$

$$\sum X^2 = 2^2 + 7^2 + 12^2 + 8^2 + 6^2 = 297$$

$$N = 5$$

$$\text{Standard Deviation } (\sigma) = \sqrt{\frac{\sum X^2}{N} - (\bar{X})^2}$$

$$\Rightarrow \sigma = \sqrt{\frac{297}{5} - (7)^2} = \sqrt{59.4 - 49}$$

$$\Rightarrow \sigma = \sqrt{10.4} = 3.225$$

We know that,

Coefficient of variation

$$= \frac{\sigma}{\bar{X}} \times 100 = \frac{3.225}{7} \times 100 = 46.07\%$$

74. (a) Given; 11, 2, 8, 9, 15, 24, 0, 18

We know that,

Geometric mean is given by;

$$\begin{aligned} &(a_1 \times a_2 \times a_3 \dots \dots \times a_n)^{\frac{1}{n}} \\ &= (11 \times 2 \times 8 \times 9 \times 15 \times 24 \times 0 \times 18)^{\frac{1}{8}} \\ &= 0 \end{aligned}$$

75. (b) Given; $E(x) = 4.5$ and $E(y) = 2.5$

$$\Rightarrow E(x - y) = E(x) - E(y)$$

$$\Rightarrow E(x - y) = 4.5 - 2.5$$

$$\Rightarrow E(x - y) = 2$$

76. (b) We know,

Categorical data is most appropriate for representing using a Pie chart.

77. (b) Given data;

x	f(x)
25-30	20
30-35	53
35-40	42
40-45	42
45-50	41
50-55	43

Here, highest frequency is 53 i.e., $f_1 = 53$

$$\Rightarrow f_0 = 20, f_2 = 42 \text{ \& } h = 5$$

Therefore, mode is given by

$$\text{Mode} = l + \frac{f_1 - f_0}{2f_1 - f_0 - f_2} \times h$$

$$= 30 + \frac{53 - 20}{2(53) - 20 - 42} \times 5$$

$$= 30 + \frac{33}{106 - 62} \times 5 = 33.75$$

78. (a) Given; $P(A) = \frac{1}{3}, P(A) = \frac{1}{4}, P\left(\frac{A}{B}\right) = \frac{1}{6}$

We know that,

$$P\left(\frac{A}{B}\right) = \frac{P(A \cap B)}{P(B)} \Rightarrow \frac{1}{6} = \frac{P(A \cap B)}{\frac{1}{4}}$$

$$\Rightarrow P(A \cap B) = \frac{1}{24}$$

Now,

$$P\left(\frac{B}{A}\right) = \frac{P(A \cap B)}{P(A)}$$

$$\Rightarrow P\left(\frac{B}{A}\right) = \frac{\frac{1}{24}}{\frac{1}{3}}$$

$$\Rightarrow P\left(\frac{B}{A}\right) = \frac{3}{24} = \frac{1}{8}$$

79. (a) Given;

$$r = \frac{1}{2}, \Sigma xy = 120, \sigma_y = 8, \Sigma x^2 = 90$$

We know,

$$r = \frac{\frac{\Sigma(x_i - \bar{x})(y_i - \bar{y})}{n}}{\sqrt{\frac{\Sigma(x_i - \bar{x})^2}{n}} \cdot \sigma_y}$$

$$\Rightarrow 0.5 = \frac{120}{n} \times \sqrt{\frac{n}{90}} \times \frac{1}{8}$$

$$\Rightarrow 0.5 = \frac{120}{\sqrt{n}} \times \frac{1}{\sqrt{90}} \times \frac{1}{8}$$

$$\Rightarrow \sqrt{n} = \frac{0.5 \times \sqrt{90} \times 8}{120}$$

$$\Rightarrow n = 10$$

80. (d) Given; the cost of living index goes up from 110 to 200 and the salary of a worker is also raised from Rs. 330 to Rs. 500

$$\text{i.e., Real wages } I = \frac{330}{110} \times 100 = \text{Rs } 300$$

$$\text{Now, Real wages } II = \frac{500}{200} \times 100 = \text{Rs } 250$$

Clearly, it is loss of Rs 50.

81. (d) Given probability density function;

$$f(x) = 6x(1-x), 0 \leq x \leq 1$$

Therefore, mean is given by

$$= \int_0^1 x \cdot f(x) dx$$

$$= \int_0^1 x^2(6x)(1-x) dx$$

$$= 6 \int_0^1 x^2(6x)(1-x) dx$$

$$= 6 \left[\int_0^1 x^2 dx - \int_0^1 x^3 dx \right]$$

$$= 6 \left(\frac{x^3}{3} \right)_0^1 - 6 \left(\frac{x^4}{4} \right)_0^1$$

$$= 6 \left(\frac{1}{3} \right) - 6 \left(\frac{1}{4} \right) = \frac{1}{2}$$

82. (b) Given, Number of red balls = 7

Number of blue balls = 5

Number of green balls = 3

Thus, total balls = 7 + 5 + 3 = 15

Now, the total number of ways of drawing 3 balls out of 15 = ${}^{15}C_3$

$$= \frac{15 \times 14 \times 13}{3 \times 2 \times 1} = 455$$

Thus, the favorable ways of getting exactly 2 blue balls out of 3

$$= {}^5C_2 \times {}^{10}C_1 = 10 \times 10 = 100$$

Therefore, the required probability = $\frac{100}{455} = \frac{20}{91}$

83. (c) Non-probability sampling is non-probabilistic, its is purely subjective and, as such, varies from person to person. No statistical hypothesis can be tested on the basis of a purposive sampling.

84. (b) Given; Correlation between two variables x and $y = 0.6$

Since, the sign of x and $-2y$ is opposite

Therefore, the correlation between x and $-2y$ is 0.6.

85. (b) 25% of the total data is represented as follow;

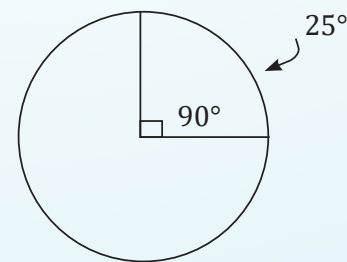

Therefore, the angle of the corresponding sector is 90°.

86. (b) Given; $P(A \cup B) = 0.6$ and $P(A \cap B) = 0.2$

We know,

$$P(A \cup B) = P(A) + P(B) - P(A \cap B)$$

$$\Rightarrow 0.6 = P(A) + P(B) - 0.2$$

$$\Rightarrow P(A) + P(B) = 0.8$$

$$\text{Now, } P(\bar{A}) + P(\bar{B})$$

$$\Rightarrow 1 - P(A) + 1 - P(B)$$

$$\Rightarrow 2 - [P(A) + P(B)]$$

$$\Rightarrow 2 - 0.8 = 1.2$$

87. (b) Series in which frequencies are continuously added corresponding to each class interval in the series in Cumulative frequency series.

88. (b) According to question, we have

$$\mu - \sigma = 40 \quad \dots(i)$$

$$\mu - \sigma = 60 \quad \dots(ii)$$

Where, μ & σ are mean and standard deviation respectively

$$\Rightarrow 2\mu = 100$$

$$\Rightarrow \mu = 50$$

We know,

$$5 \text{ M.D} = 4 \text{ S.D}$$

$$\Rightarrow \text{M.D} = \frac{4}{5} \times 100$$

$$\Rightarrow \text{M.D} = 8$$

89. (a) Given, $E(x) = 2$ and $V(x) = 6$

$$\Rightarrow np = 2 \text{ and } npq = 6$$

$$\Rightarrow \frac{npq}{np} = \frac{6}{2}$$

$$\Rightarrow n = 3$$

$$\text{Thus, } np = 2$$

$$\Rightarrow 3p = 2 \Rightarrow p = \frac{2}{3}$$

90. (b) We know that,

$$r_c = \sqrt{\frac{2c-m}{m}}$$

$$\Rightarrow \frac{1}{\sqrt{2}} = \sqrt{\frac{2(6)-m}{m}}$$

$$\Rightarrow \frac{1}{\sqrt{2}} = \sqrt{\frac{12-m}{m}}$$

$$\Rightarrow \frac{1}{\sqrt{2}} = \frac{12-m}{m}$$

$$\Rightarrow m = 24 - 2m$$

$$\Rightarrow 3m = 24 \Rightarrow m = 8$$

$$\text{Thus, } n = m + 1 = 8 + 1 = 9$$

91. (d) We know,

The number of people who are aged 40 years or younger, we need to add up the frequencies for the 20-30 age interval, the 30-40 age interval, the 40-50 age interval.

$$\text{i.e., } 10 + 20 + 30 = 60$$

Therefore, 60 people are aged 40 years or younger.

Hence, the correct option is (d) i.e., 60.

92. (d) According to the empirical rule, if the data form a "bell-shaped" distribution, the maximum and minimum frequencies occur at middle and ends respectively.

93. (c) The cost of living is always weighed index number.

94. (b) Let p = probability of a defective screw

$$= 2\% = \frac{2}{100} \text{ and } n = 100$$

$$\text{Thus, } m = np = 100 \left(\frac{2}{100} \right) = 2$$

Therefore, the probability that at least two will be defective is given by;

$$P(X \geq 2) = 1 - P(X = 0) - P(X = 1)$$

$$= 1 - \frac{e^{-2}2^0}{0!} - \frac{e^{-2}2^1}{1!}$$

$$= 1 - e^{-2} - 2e^{-2} = 1 - 3e^{-2}$$

$$= 1 - 3(0.135)$$

$$= 1 - 0.405 = 0.595$$

Hence, the required probability is 0.595.

95. (d) According to given data, we have

$$\Sigma(x - \bar{x}) = 250 \text{ and } n = 10$$

Therefore, the standard deviation is given by;

$$\sigma = \sqrt{\frac{\Sigma(x - \bar{x})}{n}}$$

$$\sigma = \sqrt{\frac{250}{10}} = 5$$

Now, the coefficient of variance is given by

$$\frac{\text{S.D}}{\text{Mean}} \times 100 = \frac{5}{10} \times 100 = 50\%$$

96. (a) We know that,

When the prices for quantities consumed of all commodities are changing in the same ratio, then the index numbers due to Laspeyre's and Paasche's will be equal.

97. (a) Given; $n = 100$, $N = 1000$, Mean = 170 and $\sigma = 10$

$$\text{Thus, } \frac{n}{N} = \frac{100}{1000} = 0.1$$

$$\text{Since, } \frac{n}{N} > 0.05$$

$$\text{Therefore, } S.E = S.E = \frac{\sigma}{\sqrt{n}} = \sqrt{\frac{N-n}{N-1}}$$

$$\Rightarrow S.E = \frac{10}{\sqrt{100}} \sqrt{\frac{1000-100}{1000-1}}$$

$$\Rightarrow S.E = \frac{10}{100} \sqrt{\frac{990}{999}}$$

$$\Rightarrow S.E = 0.995 \approx 1.0 \text{ cm}$$

98. (a) We know that,

The Laspeyre's index number is a weighted aggregate method by taking quantity consumed in the base year as weight.

99. (c) Arranging the observations in ascending order, we get

8, 15, 36, 38, 40, 41

$$Q_1 = \left(\frac{7}{4}\right)^{\text{th}} \text{ obs}$$

$$= 1^{\text{st}} \text{ obs} + 0.75 (2^{\text{nd}} - 1^{\text{st}}) \text{ obs}$$

$$= 8 + 0.75 (15 - 8) = 13.25$$

$$Q_3 = 3 \left(\frac{7}{4}\right)^{\text{th}} \text{ obs}$$

$$= 5^{\text{th}} \text{ obs} + 0.25 (6^{\text{th}} - 5^{\text{th}}) \text{ obs}$$

$$= 40 + 0.25 (41 - 40) = 40.25$$

Now, quartile deviation is given by

$$Q.D = \frac{Q_3 - Q_1}{2}$$

$$\Rightarrow Q.D = \frac{40.25 - 13.25}{2}$$

$$\Rightarrow Q.D = 13.5$$

100. (b) Given numbers; 1, 2, 3, 4...25

Let A be the event that the selected number is multiple of 5 and B be event that it is multiple of 7.

$$A = 5, 10, 15, 20, 25$$

$$B = 7, 14, 21$$

Since, A and B are mutually exclusive events then,

$$P(A \cup B) = P(A) + P(B)$$

$$\Rightarrow P(A \cup B) = \frac{5}{25} + \frac{3}{25} = \frac{8}{25}$$

